

# Brazilia F 5, F 5S, F 8S & Comfortstat 2 F 8ST

## Balanced Flue Gas Wall Heaters



---

## Installation and Owner Guide

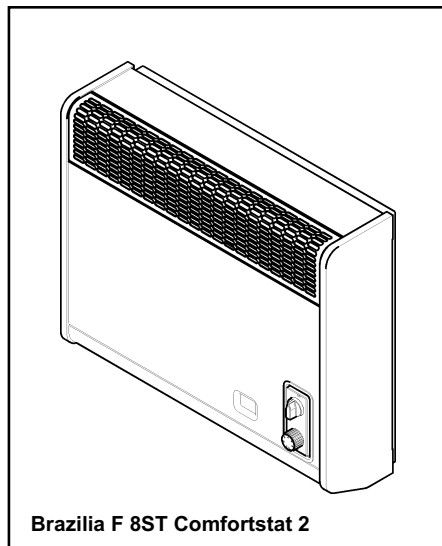
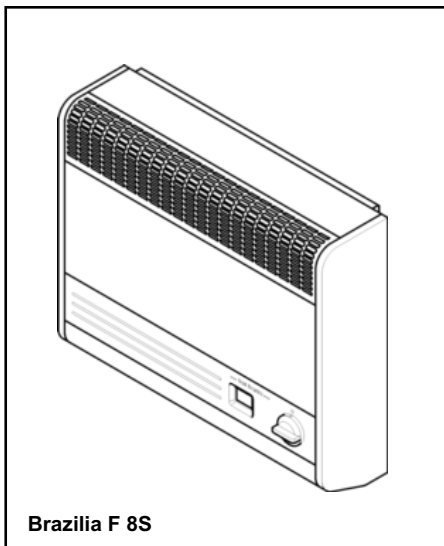
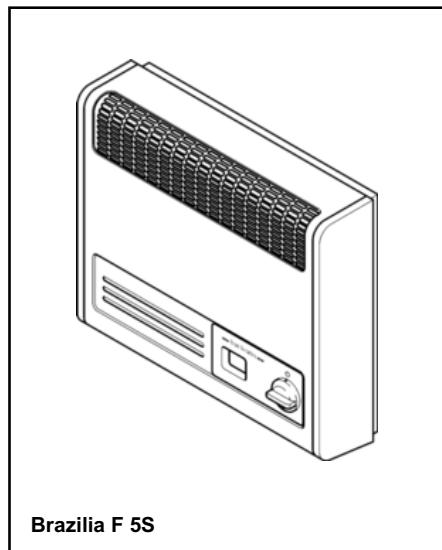
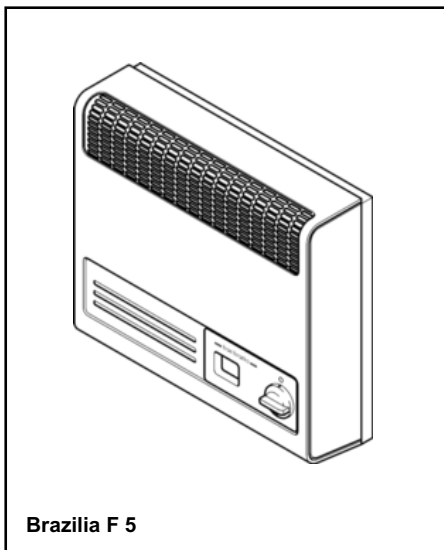

## Natural Gas

---

### **Brazilia F 5**

G.C.No. 35 075 01

### **Brazilia F 5S Mahogany**

G.C.No. 35 075 02

### **Brazilia F 5S Oak**

G.C.No. 35 075 02

### **Brazilia F 8S Mahogany**

G.C.No. 35 075 03

### **Brazilia F 8S Oak**

G.C.No. 35 075 03

### **Brazilia Comfortstat 2 F8ST Oak**

G.C.No. 35 075 10

## Propane

---

### **Brazilia F 5 Propane**

G.C.No. 35 075 04



### © GDC Group Limited

All rights reserved. No part of this publication may be reproduced in any material form (including photocopying), stored in any medium by electronic means (including in any retrieval system or database) or transmitted, in any form or by any means, whether electronic, mechanical, recording or otherwise, without the prior written permission of the copyright owner.

Applications for the copyright owner's permission to reproduce any part of this publication should be made, giving details of the proposed use, to the following address: GDC Group, Millbrook House, Grange Drive, Hedge End, Southampton, SO30 2DF, UK.

Warning: Any person who does any unauthorised act in relation to a copyright work may be liable to criminal prosecution and civil claims for damages.

Warning: Any person who does any unauthorised act in relation to a copyright work may be liable to criminal prosecution and civil claims for damages.

### The BENCHMARK Scheme

GDC Group is a licensed member of the Benchmark Scheme which aims to improve the standards of installation and commissioning of domestic heating and hot water systems in the UK and to encourage regular servicing to optimise safety, efficiency and performance. Benchmark is managed and promoted by the Heating and Hotwater Industry Council.

It places responsibilities on both manufacturers and installers. The purpose is to ensure that customers are provided with the correct equipment for their needs, that it is installed, commissioned and serviced in accordance with the manufacturer's instructions by competent persons and that it meets the requirements of the appropriate Building Regulations.

The Benchmark Checklist (on the inside back pages of this guide) can be used to demonstrate compliance with Building Regulations and should be provided to the customer for future reference.

Installers are required to carry out installation, commissioning and servicing work in accordance with the Benchmark Code of Practice which is available from the Heating and Hotwater Industry Council who manage and promote the Scheme. Visit [www.centralheating.co.uk](http://www.centralheating.co.uk) for more information.

At the time of commissioning, complete all relevant sections of the Benchmark Checklist located on the inside back pages of this document.



For GB/IE only.

## Contents

Section	Page(s)
<b>Installer guide</b>	<b>3 - 17</b>
<b>1.0 Introduction</b>	<b>4 - 5</b>
<b>2.0 Technical Data</b>	<b>6 - 7</b>
<b>3.0 Site Requirements</b>	<b>8 - 10</b>
<b>4.0 Installation</b>	<b>11</b>
<b>5.0 Commissioning the Appliance</b>	<b>12</b>
<b>6.0 Annual Servicing</b>	<b>13</b>
<b>7.0 Changing Components</b>	<b>14 - 17</b>
<b>8.0 Fault Finding</b>	<b>18</b>
<b>9.0 Short Parts List</b>	<b>19</b>
<b>Owner guide</b>	<b>20- 27</b>
<b>1.0 Warnings</b>	<b>21</b>
1.1 Safe Installation	21
1.2 In case of gas leaks	21
1.3 Guarding	21
1.4 Servicing your Appliance	21
<b>2.0 Introduction &amp; Operation</b>	<b>22</b>
2.1 Introduction	22
2.2 Operating units that are not fitted with the Comfortstat control	22
2.3 Operating units fitted with the Comfortstat control	23
<b>3.0 Cleaning &amp; Clearances</b>	<b>24</b>
3.1 Cleaning the Appliance	24
3.2 Clearances	24
<b>4.0 Spares &amp; Running costs</b>	<b>25</b>
4.1 Spare Parts	25
4.2 Running Costs	25
<b>5.0 Troubleshooting</b>	<b>26</b>
<b>6.0 Warranty, Benchmark &amp; Service</b>	<b>27-30</b>
<b>7.0 Warning</b>	<b>27</b>

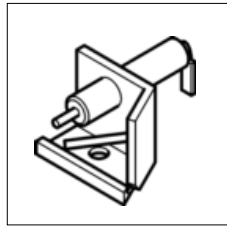
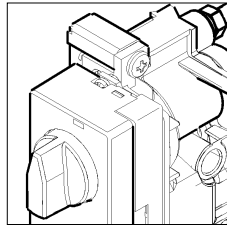
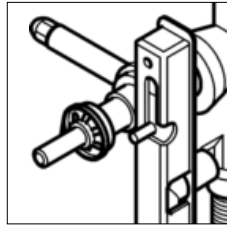
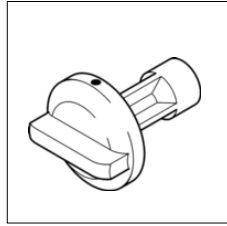

### Installer

Before continuing any further with the installation of this appliance please read the following guide to manual handling:

- The lifting weight of this appliance is as below:

<u>Model</u>	<u>Gross weight (kg)</u>
F 5	18.0.
F 5S	19.1.
F 8S & F 8ST	24.4.

- One person should be sufficient to lift the fire. If for any reason this weight is considered too heavy then obtain assistance.
- When lifting always keep your back straight. Bend your legs and not your back.
- Avoid twisting at the waist. It is better to reposition your feet.
- Avoid upper body/top heavy bending. Do not lean forward or sideways whilst handling the fire.
- Always grip with the palm of the hand. Do not use the tips of fingers for support.
- Always keep the fire as close to the body as possible. This will minimise the cantilever action.
- Use gloves to provide additional grip.
- Always use assistance if required.

## 1.0 Introduction

**IMPORTANT:** The appliance must only be used on its designated gas type. This is indicated on the information label.

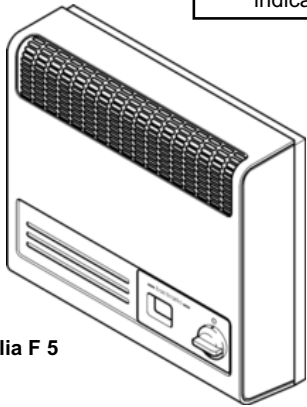

Brazilia F 5

Fig. 1

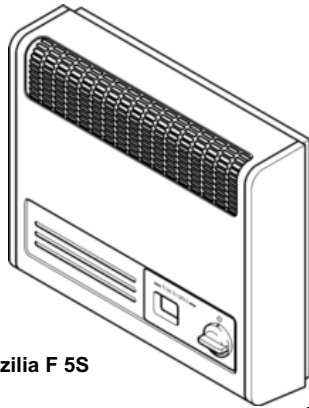

Brazilia F 5S

Fig. 2

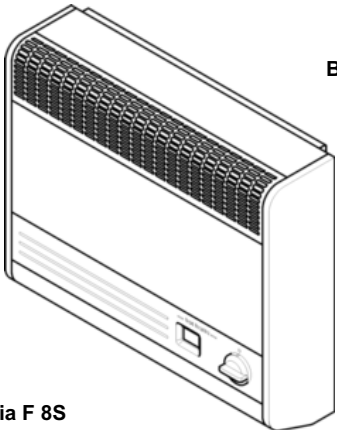

Brazilia F 8S

Fig. 3

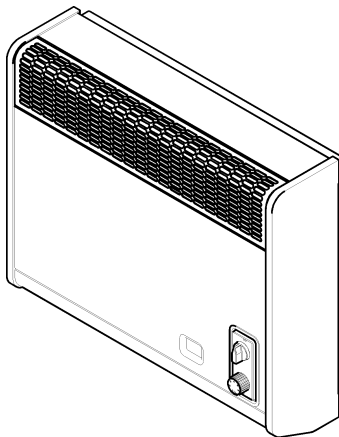

Brazilia F 8ST

Fig. 4

### 1.1 Description

- The Brazilia F is a range of room sealed gas convector appliances designed to be used with gas type G20 (Natural Gas) at supply pressure 20 mbar. When converted using the below kits the non thermostatic range is also suitable for use with gas type G31 (Propane) at supply pressure 37 mbar.

#### LPG Kits

F 5 & F 5S 5110284

F8S 5110285

The procedure for installation, servicing etc. is the same for both Natural Gas and Propane models.

- The appliance provides warm air by natural convection and flueing is by means of a concentric balanced flue arrangement.

- Except for Comfortstat, the appliance is controlled by a control knob which operates the ignition and alters the heat output. The control knob has five positions giving a choice of three output rates:

Position ●	OFF
Position	LOW
Position ★	IGNITION
Position	MEDIUM
Position	HIGH

- (Comfortstat only)

The appliance is controlled by an upper control knob which operates the ignition and burner setting.

Position ●	OFF
Position ★	IGNITION
Position ◊	LOW
Position ◊	HIGH

A lower control knob alters the temperature setting, the knob has seven positions.

## 1.0 Introduction

### 1.2 Regulations, Standards and Law.

The installation must be in accordance with this guide. For the user's protection, in the United Kingdom it is the law that all gas appliances are installed by competent persons in accordance with the current edition of the Gas Safety (Installation and Use) Regulations. Failure to install the appliance correctly could lead to prosecution. GAS SAFE REGISTER and CORGI require their members to work to recognised standards.

In the United Kingdom the installation must also be in accordance with:

All the relevant parts of local regulations.

The relevant parts of the current editions of the following British Standards:-

BS 5440 Part 1-	Installation of flues
BS 5871 Part 1-	Installation - Gas fires
BS 6891-	Installation of low pressure gas pipework of up to 35mm (R1 ¼) in domestic premises (2nd family gas) - specification.

- In England and Wales, the current edition of the Building Regulations issued by the Department of the Environment and the Welsh Office.
- In Scotland, the current edition of the Building Standards (Scotland) Regulations issued by the Scottish Executive.
- In Northern Ireland, the current edition of the Building regulations (Northern Ireland) issued by the Department of the Environment for Northern Ireland.
- In the republic of Ireland the installation must be carried out by a competent person and also conform to the relevant parts of:

a) The current edition of IS 813 "Domestic Gas Installations"

b) All relevant national and local rules in force.

Where no specific instructions are given, reference should be made to the relevant British Standard Code of Practice.

### 1.3 Considerations for timber framed buildings.

Installation to a timber-framed building should be in accordance with the relevant sections of The Institute of Gas Engineers publication IGE/UP/7 "Gas installations in timber frame buildings".

Please note that advice should be sought before installing in a timber frame building since the alterations required may nullify any NHBC cover relating to the property. If in doubt, guidance should be requested from your local authority planning or building department.

**Under no circumstances is the fire to be recessed into timber frame constructions.**

### 1.4 Ventilation requirements.

No special ventilation bricks or vents are required into the room containing the appliance.

### 1.5 Fireguard requirements.

A fireguard complying with BS 8423 should be fitted for the protection of young children, the elderly, the infirm and pet animals.

### 1.6 Room considerations.

It is advisable that combustible fabrics such as curtains are not fitted above the fire. If, however, this is unavoidable, the extreme bottom edge of the fabric must be at least 780mm above the base of the fire.

### 1.7 Important Information.

**This product uses insulation board and gaskets containing Refractory Ceramic Fibres (RCF), which are man-made vitreous silicate fibres. Excessive exposure to these materials may cause irritation to eyes, skin and - respiratory tract. Consequently, it is important to take care when handling these articles to ensure that the release of dust is kept to a minimum. To ensure that the release of fibres from these RCF articles is kept to a minimum, during installation and servicing we recommend that you use a HEPA filtered vacuum to remove any dust and soot accumulated in and around the fire before and after working on the fire. When replacing these articles we recommend that the replaced items are not broken up, but are sealed within a heavy duty polythene bag, clearly labelled as RCF waste. RCF waste is classed as a stable, non-reactive hazardous waste and may be disposed at a landfill licenced to accept such waste. Protective clothing is not required when handling these articles, but we recommend the use of suitable gloves to prevent irritation. We also recommend you follow the normal hygiene rules of not smoking, eating or drinking in the work area and always wash your hands before eating or drinking. This appliance does not contain any component manufactured from asbestos or asbestos related products.**

#### Notice

Discolouration of wall surfaces

Most heating appliances generate warm air convection currents and transfer heat to any wall surface against which they are situated.

Some soft furnishings (such as blown vinyl wallpapers) may not be suitable for use where they are subject to temperatures above normal room levels and the manufacturer's advice should be sought before using this type of wall covering adjacent to any heating appliance.

The likelihood of wall staining from convected air currents will be increased in environments where high levels of tobacco smoke or other contaminants exist.

## 2.0 Technical Data

### F 5 & F 5S Natural Gas

Category of Appliance II<sub>2H3P</sub>  
 The appliance is set for Gas Type G20 at 20mbar.

Heat Input (gross)	High	Med	Low
kW	2.05	1.41	0.86
Btu/h	7,000	4,800	3,000

Heat Output (gross)	High	Med	Low
kW	1.5	0.98	0.57
Btu/h	5,100	3,350	1,950

Setting Pressure	Cold	
mbar		19.7 ± 0.75
in wg		7.9 ± 0.3

Injector Size	CO <sub>2</sub>

Nox Class	3

Gas Rate on HIGH	0.195 m <sup>3</sup> /h (6.89 ft <sup>3</sup> /h)

Gas Connection	R 1/4 (1/4 BSP external)

Ignition	Piezo Spark

Packed Weight	F 5	F 5S
	18 kg (39.7 lbs)	18.4 kg (40.6 lbs)

Dimensions	F 5	F 5S
Height	394mm	394mm
Width	426mm	450mm
Depth (from the wall)	126mm	128mm

Controls	Rotary gas tap allowing manual adjustment between low, medium and high output. Flame failure device.

Thermocouple Output	8-13mv

Heat Exchanger	Cast Iron

### F 8S & F 8ST Natural Gas

Category of Appliance F 8S II<sub>2H3P</sub>  
 Category of Appliance F 8ST I<sub>2H</sub>  
 The appliance is set for Gas Type G20 at 20mbar.

Heat Input (gross)		Except Comfort Stat		
		High	Med	Low
kW		3.06	2.21	1.50
Btu/h		10,440	7,540	5,118

Heat Output (gross)		Except Comfort Stat		
		High	Med	Low
kW		2.26	1.48	0.6
Btu/h		7,700	5,050	2,047

Setting Pressure	Cold	
F Range	mbar	19.25 ± 0.75
	in wg	7.7 ± 0.3

Setting Pressure	Cold	
Comfortstat	mbar	20.00 ± 1.00
	in wg	8.0 ± 0.4

Injector Size	CO <sub>1</sub>

Nox Class	2

Gas Rate on HIGH	0.29 m <sup>3</sup> /h (10.28 ft <sup>3</sup> /h)

Gas Connection	F 8S - R 1/4 (1/4 BSP external) F 8ST - 8mm nut and olive

Ignition	Piezo Spark

Packed Weight	F 8S & F 8ST
	24.4 kg (54 lbs)

Dimensions	F 8S	F 8ST
Height	430mm	430mm
Width	516mm	516mm
Depth (from the wall)	152mm	170mm

Controls	Rotary gas tap allowing manual adjustment between low, medium and high output. Flame failure device.
Non Thermostat	

Controls	Rotary thermostat allowing a low position and adjustment between low and high temperature settings. Flame failure device.
Comfortstat	

Thermocouple Output	8-13mv

Heat Exchanger	Cast Iron

## 2.0 Technical Data

### F 5 & F 5S Propane

(When converted using kit No. 5110284)

Category of Appliance II<sub>2H3P</sub>

The appliance is set for Gas Type G31 at 37mbar.

Heat Input (gross)	High	Med	Low
kW	2.05	1.41	0.86
Btu/h	7,000	4,800	3,000

Heat Output (gross)	High	Med	Low
kW	1.5	0.98	0.57
Btu/h	5,100	3,350	1,950

Setting Pressure	Cold	
mbar		36.5 ± 1
in wg		14.6 ± 0.4

Injector Size	74
---------------	----

Nox Class	3
-----------	---

Gas Rate on HIGH	0.077 m <sup>3</sup> /h (0.146 kg/h)
------------------	--------------------------------------

Gas Connection	R 1/4 (1/4 BSP external)
----------------	--------------------------

Ignition	Piezo Spark
----------	-------------

Packed Weight	F 5	F 5S
	18 kg (39.7 lbs)	18.4 kg (40.6 lbs)

Dimensions	F 5	F 5S	
	Height	394mm	394mm
	Width	426mm	450mm
	Depth (from the wall)	126mm	128mm

Controls	Rotary gas tap allowing manual adjustment between low, medium and high output. Flame failure device.
----------	---

Thermocouple Output	8-13mv
---------------------	--------

Heat Exchanger	Cast Iron
----------------	-----------

### F 8S Propane

(When converted using kit No. 5110285)

Category of Appliance II<sub>2H3P</sub>

The appliance is set for Gas Type G31 at 37mbar.

Heat Input (gross)	High	Med	Low
kW	3.06	2.21	1.27
Btu/h	10,440	7,540	4,333

Heat Output (gross)	High	Med	Low
kW	2.26	1.48	0.80
Btu/h	7,700	5,050	2,730

Setting Pressure	Cold	
mbar		36.5 ± 1
in wg		14.6 ± 0.4

Injector Size	90
---------------	----

Nox Class	2
-----------	---

Gas Rate on HIGH	0.115 m <sup>3</sup> /h (0.218 kg/h)
------------------	--------------------------------------

Gas Connection	R 1/4 (1/4 BSP external)
----------------	--------------------------

Ignition	Piezo Spark
----------	-------------

Packed Weight	F 8S
	24.4 kg (54 lbs)

Dimensions	F 8S	
	Height	430mm
	Width	516mm
	Depth (from the wall)	152mm

Controls	Rotary gas tap allowing manual adjustment between low, medium and high output. Flame failure device.
----------	---

Thermocouple Output	8-13mv
---------------------	--------

Heat Exchanger	Cast Iron
----------------	-----------

### 3.0 Site Requirements

#### 3.1 Location

1. The appliance must be fitted on a suitable outside wall to meet the requirements of the balanced flue arrangement.
2. For applications involving walls constructed from or comprising of combustible material, reference should be made to the requirements of B.S. 5871 and Building Regulations.
3. Building Regulations will require the flue duct to be separated from any combustible material within the wall by a non-combustible sleeve enclosing an annular air space of at least 25mm (1 in) around the flue duct.
4. If the outer face of the wall is combustible, a plate of metal (or other non-combustible material) should be fitted over the flue duct extending at least 50mm (2 in) around the terminal.
5. Further guidance on timber frame construction is given in the Institute of Gas Engineers UP7. "Guide for Gas Installations in Timber Framed Dwellings".

#### 3.2 Clearances

1. The appliance must be fitted on a vertical flat non-combustible wall. Any combustible wall coverings should be removed from within the area of the outer case.
2. Internally the appliance must not be fitted under a shelf or sill which has a projection of more than 150mm (6 in).
3. Curtains or a shelf must not be closer than 140mm (5½ in) (F 5 & F 5S), 89mm (3½ in) (F 8S & F 8ST) from top of outer case.
4. The bottom of the outer case must be a minimum of 72mm (2⅞ in) from the floor. Subject to this minimum dimension it is recommended that the appliance is fitted as close to the floor as possible for optimum distribution of heat.
5. Minimum side clearance from any wall or fixed furniture to the outer case is:

Left hand side:	45mm (1¾ in)
Right hand side:	57mm (2¼ in)

**IMPORTANT: LPG Models.**

This appliance must not be installed below ground in basements, cellars, etc. unless these are open to ground level on one side. For further guidance see BS 5871 Pt.1.



**3.0 Site Requirements**

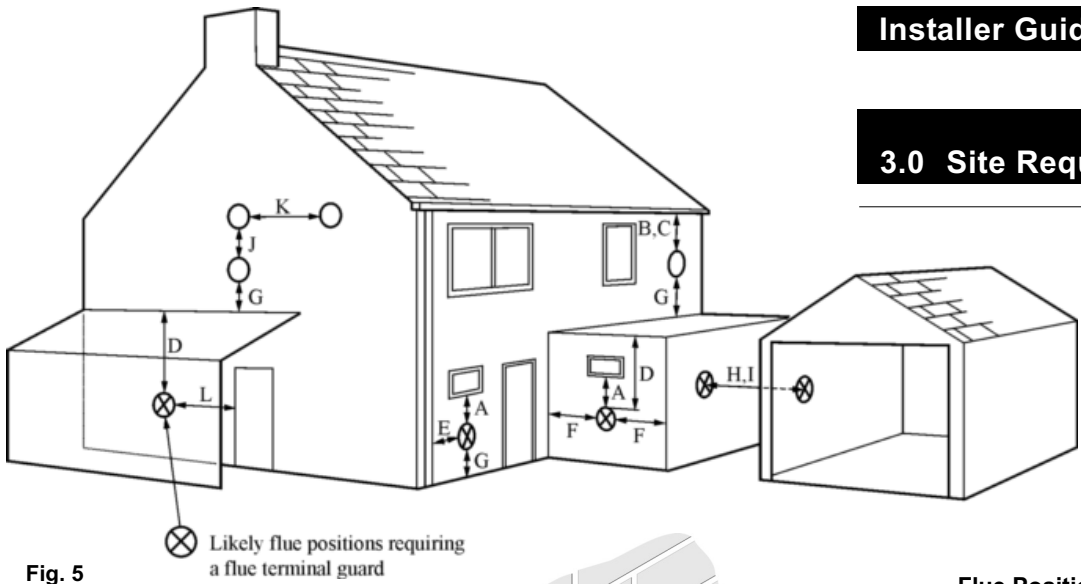

**Fig. 5**

**Flue Position**

1. The siting of the balanced flue terminal must meet the following conditions:

a. Where the flue terminal of the appliance is beneath any opening (that is to say, any part of a window capable of being opened, or any ventilation inlet or similar opening) no part of the terminal shall be within 300mm (1 ft), measured vertically from the bottom of the opening.

b. Where the flue terminal of the appliance is less than 2m (6 ft) above the level of any ground, balcony, flat roof or place to which any person has access and which adjoins the wall in which the flue terminal is situated, the terminal shall be protected by a guard.

c. The guard must be screwed to the wall over the flue terminal and be at least 50mm (2 in) clear of any part of the terminal. A suitable guard is available direct from the GDC Group service dept., Part No. 080266 (Fig. 6).

d. Not within 300mm (1 ft) of ground level.

2. Fig. 4 shows the positioning of the flue terminal relative to buildings and other structures.

3. If the outer face of the outside wall is of combustible material (timber, etc.) a metal or other non-combustible material plate should be fitted round the flue terminal so that it extends not less than 50mm (2 in) around the terminal. A 179mm (7 in) square or a 230mm (9 in) diameter circular plate will meet the requirement.

4. The flue should run horizontally, or with a slight drop to the terminal, in order to prevent rain entry (Fig. 7).

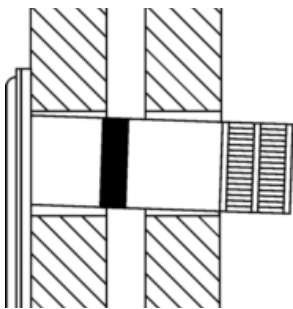

**Fig. 7** (side view). Angle of drop shown exaggerated.

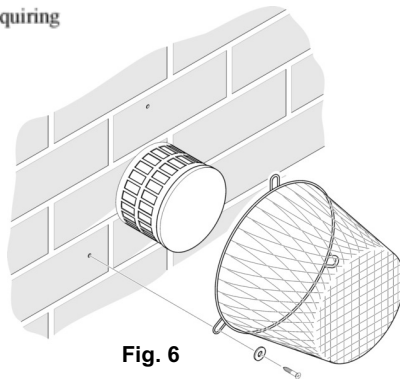
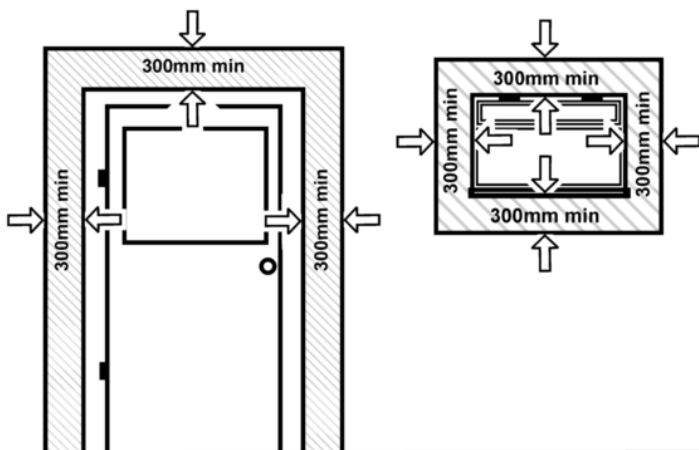

**Fig. 6**

**Terminal Position with Minimum Distance (mm)**

A*	Directly below an openable window or other opening, e.g. an air brick.	300
B*	Below gutters.	300
C*	Below eaves, soil pipes or drain pipes.	300
D	Below balconies or car port roof	600
E	From vertical drain pipes and soil pipes.	300
F	From internal or external corners.	600
G	Above ground, roof or balcony level.	300
H	From a surface facing a terminal.	600
I	From a terminal facing a terminal.	600
J	Vertically from a terminal on the same wall.	1500
K	Horizontally from a terminal on the same wall.	300
L	For an opening in a car port (e.g. door, window) into a dwelling.	1200

\*In addition, the terminal should not be nearer than 300mm to an opening in the building fabric formed for the purpose of accommodating a built-in element such as a window frame or door frame (Fig. 8).



**Fig. 8**

## 3.0 Site Requirements

### 3.4 Flue Dimensions

1. The standard appliance is supplied with flue ducting which is adjustable to accommodate wall thicknesses from 248mm (9<sup>3</sup>/<sub>4</sub> in) to 349mm (13<sup>3</sup>/<sub>4</sub> in).

2. Two further flue terminals are available as optional extras to suit the wall thicknesses indicated in the table opposite.

### 3.5 Ventilation

1. The appliance is room sealed and therefore requires no purpose built ventilation.

2. It is intended for use in habitable rooms, and must not be fitted in cupboards or confined compartments.

### 3.6 Gas Supply

1. The inlet connection is located on the gas tap at the bottom right hand side of the appliance. Comfortstat models have an 8mm nut and olive connection. All other models use R<sup>1</sup>/<sub>4</sub> (1/4 BSP external).

2. A gas service cock must be fitted in the supply to the appliance with a disconnecting union between the service cock and the inlet connection.

**NOTE:** If the gas supply is run either to the left or right on leaving the appliance, at least the first 51mm (2 in) from the inlet connection must run vertically downwards to avoid the outer case fouling the gas supply.

### Flue Option

Wall Thickness	F8S & F8ST	F5 & F5S
381mm-483mm (15in - 19in)	Part N° 243857	Not available
520mm-610mm (20 <sup>1</sup> / <sub>2</sub> in - 24in)	Part N° 243848	Not available

**4.0 Installation**

**4.1 Preparation**

1. Ensure that the length of the flue ducting is suitable for the wall thickness.
2. Select a position for the appliance. Using the template supplied, mark the position of the flue ducting and the four fixing holes. Ensure that the template is vertical (Fig. 9 or 10 depending on model).
3. Cut a neat hole 127 - 140mm (5 - 5½ in) in the wall for the flue.
4. Drill and plug the wall at the four fixing holes using a 6mm (¼ in) drill.

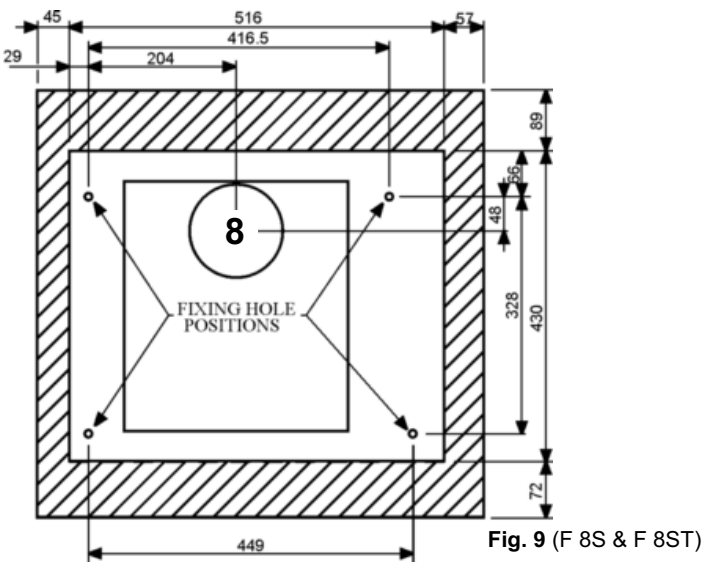

**Fig. 9 (F 8S & F 8ST)**

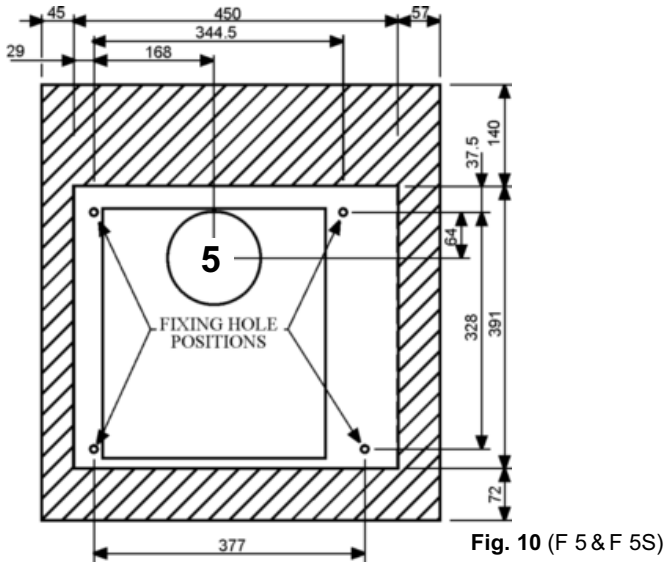

**Fig. 10 (F 5 & F 5S)**

**4.2 Fitting the Appliance**

1. Slide the flue duct and terminal assembly into the flue outlet at the rear of the appliance. Ensure that the flue duct spotwelds are not at the bottom.
2. To determine the flue length, measure the wall thickness and add 20mm (¾ in). Adjust the distance from the back of the airbox and the joint between the terminal and air duct to this dimension. Using the length of flue tape provided fix this dimension by taping up the joint between the flue duct assembly and the flue outlet.
3. Offer the appliance up to the wall pushing the terminal and flue ducting through the wall.
4. Ensuring that the appliance is level, secure it to the wall using four suitable screws and washers. Check that the wall sealing ring is correctly positioned and seals against the wall (Fig. 11).
5. Ensure that the flue terminal protrudes sufficiently on the outside wall face (Fig. 11). Make good as appropriate.
6. Connect the gas supply incorporating a gas service cock and a disconnecting union between the service cock and the inlet connection.
7. Check for gas soundness (B.S. 6891).

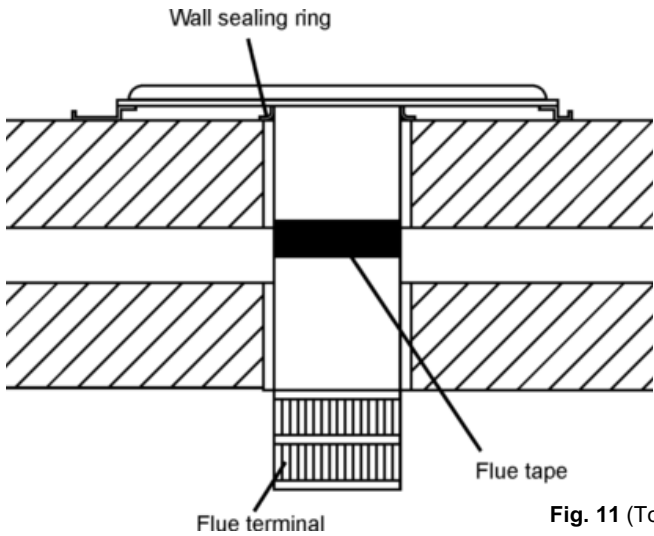

**Fig. 11 (Top View)**

## 5.0 Commissioning the Appliance

### 5.1 Commissioning the Appliance

1. Turn on the gas service cock.
2. Where applicable, fit the control knob onto the control tap spindle (Fig. 12).
3. Purge any air from the system.
4. Non Comfortstat models - Remove the pressure test point screw.  
Comfortstat models - Loosen the pressure test point screw.  
Fit a pressure gauge to the pressure test point (Fig. 12).
5. Push the control knob in and turn anticlockwise to the ignition (★) / (✦) position. The main burner should light. Keep the control knob pushed in for 20 seconds. If the burner fails to remain alight repeat the procedure. Check that the gas supply is correct by measuring the pressure at the test point on the gas control tap.
6. No adjustment is provided on the appliance. If it is found that the test pressure is not within the tolerances given, consult the gas supplier.
7. Push in and turn the control knob back to the OFF (●) position. Remove pressure gauge and replace the pressure test point screw.
8. Relight the appliance and check for gas soundness.

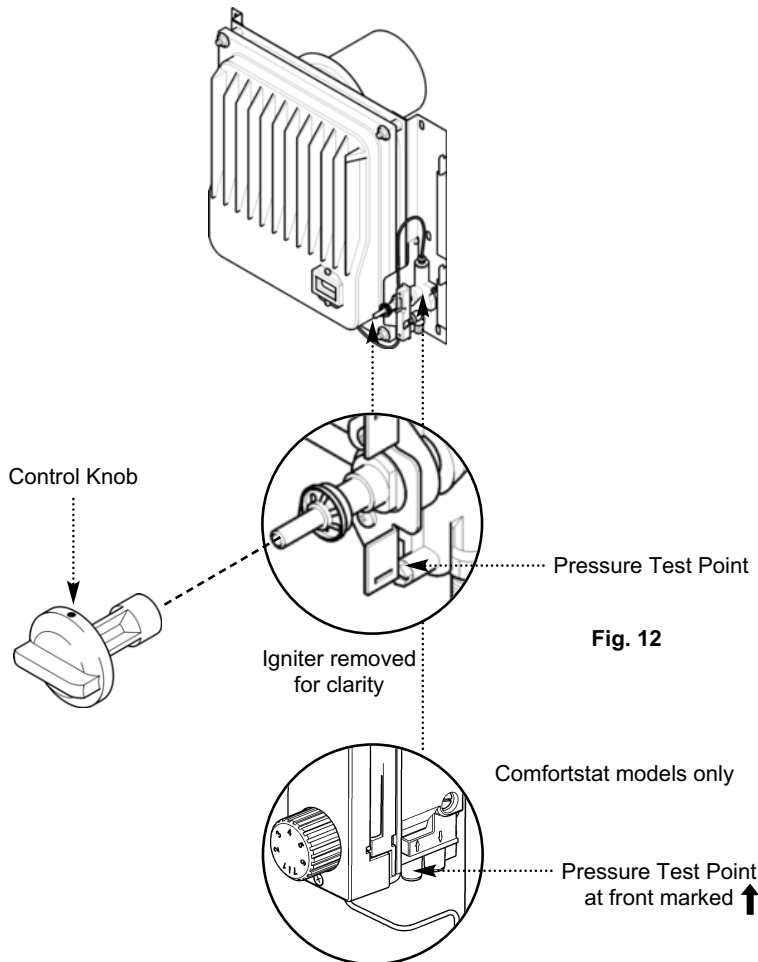

Fig. 12

N.G. Setting Pressure (Cold/High Rate)	
<b>F5 &amp; F5S</b> 19.7 ± 0.75mbar (7.9 ± 0.3in wg)	<b>F8S</b> 19.25 ± 0.75mbar (7.7 ± 0.3in wg)
	<b>F8ST Comfortstat 2</b> 20.00 ± 1.0mbar (8.0 ± 0.4in wg)
L.P.G. Setting Pressure (Cold/High Rate)	
<b>F5 &amp; F5S</b> 36.5 ± 1mbar (14.6 ± 0.4in wg)	<b>F8S</b> 36.5 ± 1mbar (14.6 ± 0.4in wg)

Fig. 13

### 5.2 Fitting the Outer Case

Before fitting the case it is important that the details on the last page of this guide are completed.

1. Push in and turn the control knob back to the OFF (●) position.
2. On models not fitted with the Comfortstat control, remove the knob from the appliance by gently pulling the knob forward (Fig. 12).
3. Fit the outer case by locating the slots in the outer case rear strip onto the four mounting lugs on the wall brackets (Fig. 14).
4. Where applicable, replace the control knob (Fig. 14).

### 5.3 Instructing the User

1. Explain how to ignite the appliance and alter the heat settings.
2. Show the position of the external gas service cock.
3. Instruct the user that the bottom and top of the case must never be obstructed in any way and emphasise that clothes etc must never be hung over the appliance to dry as this will cause overheating and possible damage.
4. Hand over this guide and recommend that for reasons of safety and economy the appliance should be serviced annually by a competent person.

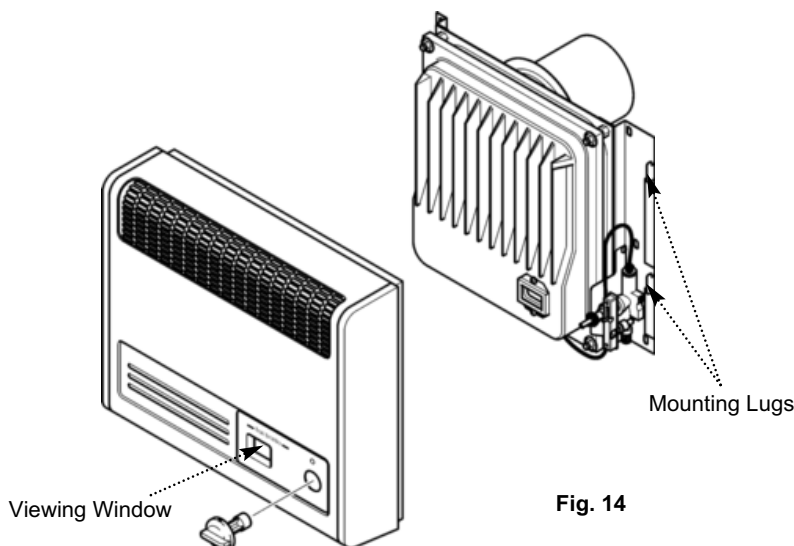
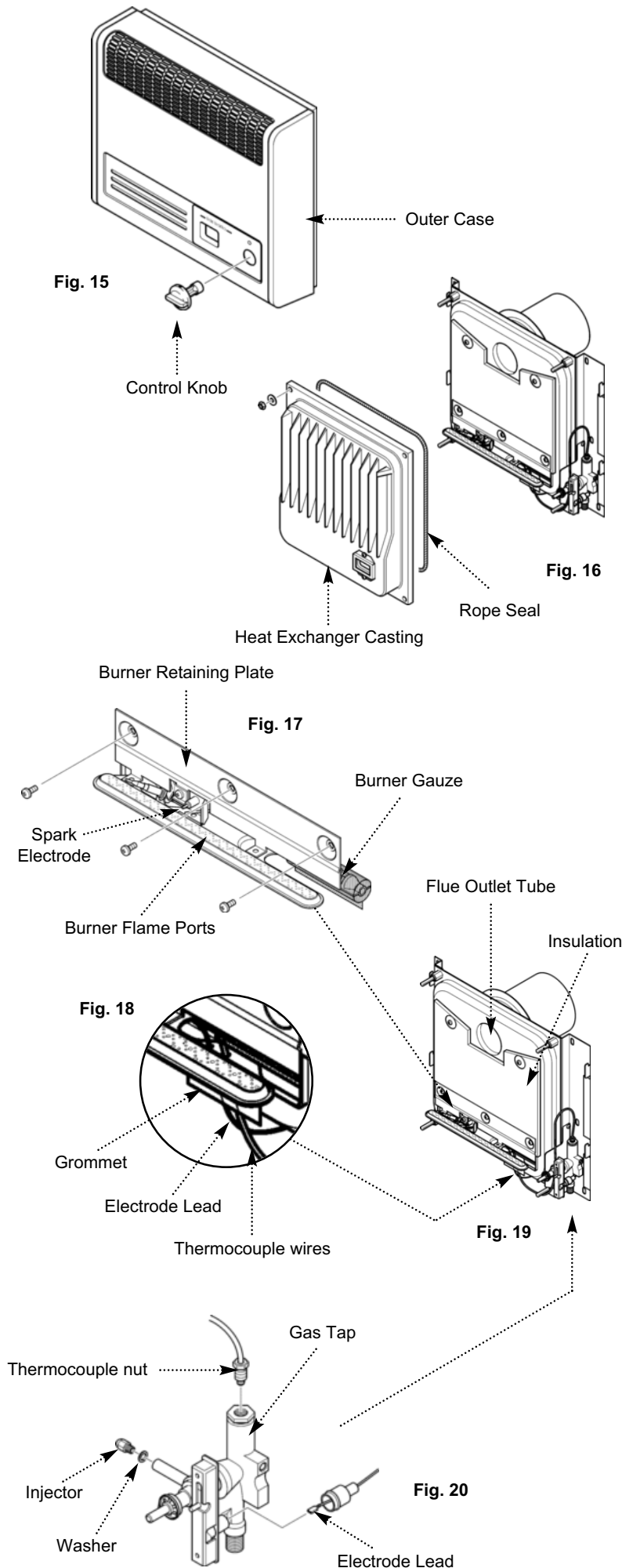

Fig. 14

## 6.0 Annual Servicing

### 6.1 Servicing the Appliance

1. For reasons of safety and economy the appliance should be serviced annually.
2. Before servicing please read Section 1.3 Important Information.
3. Turn off the gas supply and ensure that the appliance is cold.
4. On models not fitted with the Comfortstat control, remove the control knob by pulling forward.
5. Remove the case by easing upward and forward until it is clear of its retaining lugs.
6. Undo the heat exchanger retaining nuts and washers (Fig. 16) and draw the casting forward off the locating studs.
7. Remove the three screws holding the burner retaining plate to the airbox and undo the thermocouple nut from the gas tap (Fig. 17 & 20).
8. Ease the thermocouple and electrode lead from the rubber grommet (Fig. 18).
9. Disengage the burner from the injector and pull the electrode lead off the spark electrode (Fig. 17).
10. Check that the insulation is undamaged. Replace if necessary. (Fig. 19).
11. Remove and clean the injector and sealing washer. The injector must not be cleaned with a needle or wire (Fig. 20). If the sealing washer is damaged it must be replaced.
12. Check that the flue outlet tube is clear (Fig. 19).
13. Brush away any dirt from the heat exchanger casting. If necessary clean the viewing window.
14. With a light brush carefully remove deposits from the spark electrode, burner flame ports and the burner gauze (Fig. 17).
15. Replace the rope seal in the heat exchanger casting if it is damaged in any way (Fig. 16). Also examine the thermocouple and replace if necessary.
16. Re-assemble the injector, washer and burner assembly in reverse order of dismantling. Ensure that the spark gap is correct ie.  $3.5\text{mm} \pm 0.5\text{mm}$ . Check that the burner is horizontal and correctly positioned on the injector with the gauze covering the primary aeration hole.
17. Check the gas pressure at the test point on the gas control tap. If the pressure is not within the tolerance, (see Section 2.0 Technical Data) the gas supply to the unit needs to be investigated.
18. Check that the burner ignition is satisfactory. Ensure that the thermocouple/electrode lead grommet is correctly positioned and re-fit the heat exchanger casting.
19. Check for gas soundness.
20. Fit the case and control knob (where applicable) and re-check that the ignition is satisfactory.



## 7.0 Changing components on models without the Comfortstat control

### 7.1 Changing Components

1. Before changing any components please read Section 1.3 Important Information.
2. Turn off the gas supply and ensure that the appliance is cold.
3. Remove the control knob by pulling forward, then remove the case by easing upwards and forwards until it is clear of its retaining lugs (Fig. 21).
4. After changing any components re-commission the appliance

### 7.2 Piezo Unit (Fig. 22).

1. Pull off the spark lead at the rear of the igniter.
2. Straighten the tabs securing the piezo unit to the tap retaining plate and remove.
3. Fit the new piezo unit and twist the tabs slightly to secure.
4. Replace all components in the reverse order of dismantling.

### 7.3 Gas Control Tap

1. Undo the heat exchanger retaining nuts and washers and draw the casting forwards off the locating studs.
2. Remove the three screws holding the burner retaining plate to the airbox and undo the thermocouple nut from the gas tap (Fig. 23 & 25).
3. Ease the thermocouple and electrode leads from the rubber grommet (Fig. 24).
4. Disengage the burner from the injector and pull the electrode lead off the spark electrode (Fig. 23).
5. Pull off the spark electrode lead at the rear of the igniter (Fig. 25).
6. Remove the supply pipe from the gas tap.
7. Undo the nut holding the gas tap to its retaining bracket, and disengage the tap from the bracket (Fig. 25).
8. Remove the injector and sealing washer. If the washer is damaged it must be replaced.
9. On re-assembly ensure that the airbox sealing grommet is correctly positioned and check for gas soundness.

Fig. 21

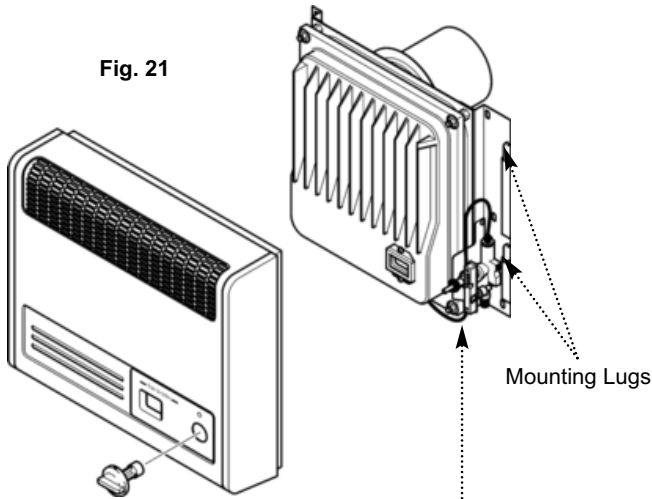

Fig. 22

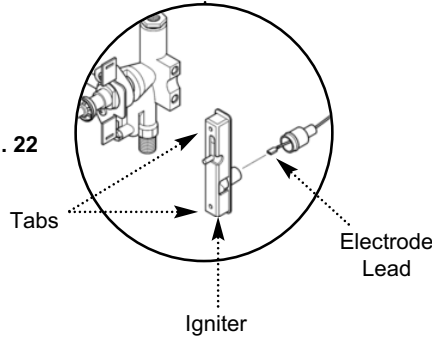

Fig. 23

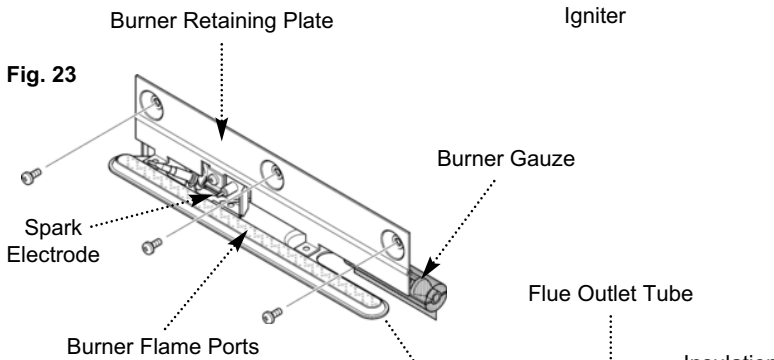

Fig. 24

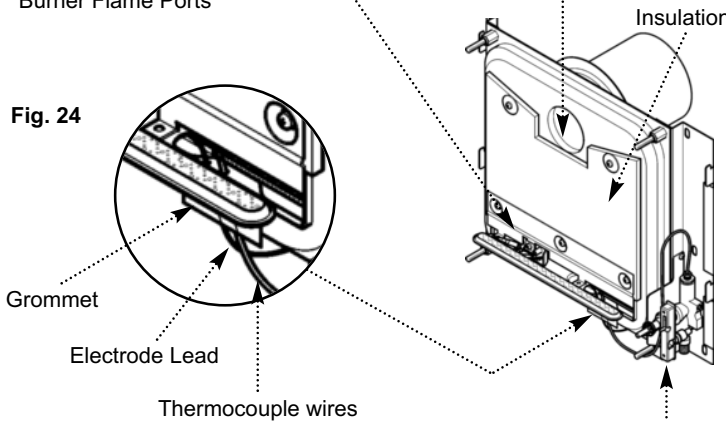
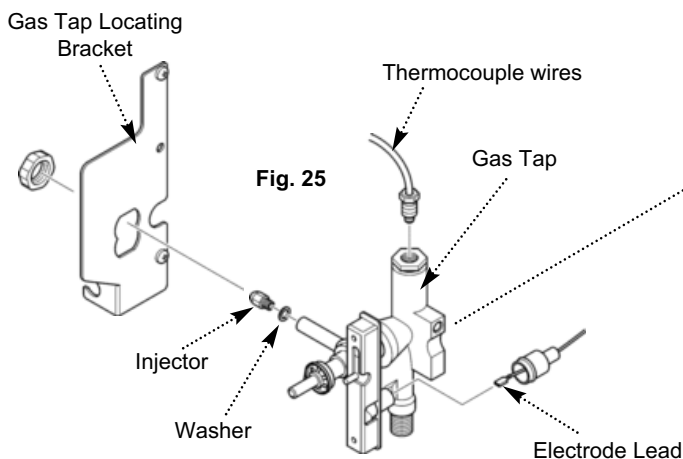

Fig. 25



## 7.0 Changing components on models without the Comfortstat control

### 7.4 Burner

1. Undo the heat exchanger retaining nuts and washers and draw the casting forwards off the locating studs (Fig. 26).
2. Remove the three screws holding the burner retaining plate to the airbox, also remove the insulation and undo the thermocouple nut from the gas tap (Fig. 27 & 29).
3. Ease the thermocouple and electrode lead from the rubber grommet (Fig. 28).
4. Disengage the burner from the injector and pull the electrode lead off the spark electrode (Fig. 27).
5. Remove the intake gauze from the burner inlet and undo the screws securing the burner to its' retaining plate, noting the position of the shield at the left hand side (Fig. 27).
6. Undo the screw securing the spark electrode to the burner. Fit the electrode to the new burner (Fig. 27).
7. Fit the intake gauze to the burner inlet ensuring that it covers the primary aeration hole (Fig. 27).
8. Reassemble in reverse order of dismantling.

### 7.5 Injector

1. Remove the burner as described in sections 7.4.1 to 7.4.4 .
2. Undo the injector and sealing washer, retaining the washer for use with the new injector. If the washer is damaged it must be replaced (Fig. 29).
3. Reassemble in reverse order of dismantling.

### 7.6 Thermocouple

1. Remove the burner as described in sections 7.4.1 to 7.4.4 .
2. Undo the nut retaining the thermocouple tip to the burner bracket and withdraw the thermocouple (Fig. 29).
3. Bend the new thermocouple in a similar manner to the one removed. Avoid any sharp bends.
4. On reassembly ensure that the airbox sealing grommet is correctly positioned.

Fig. 26

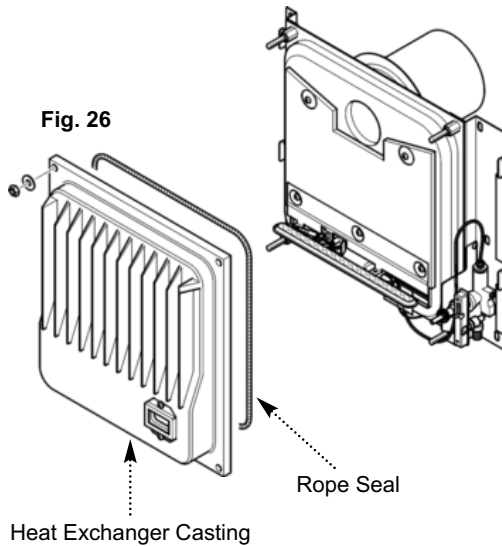

Fig. 27

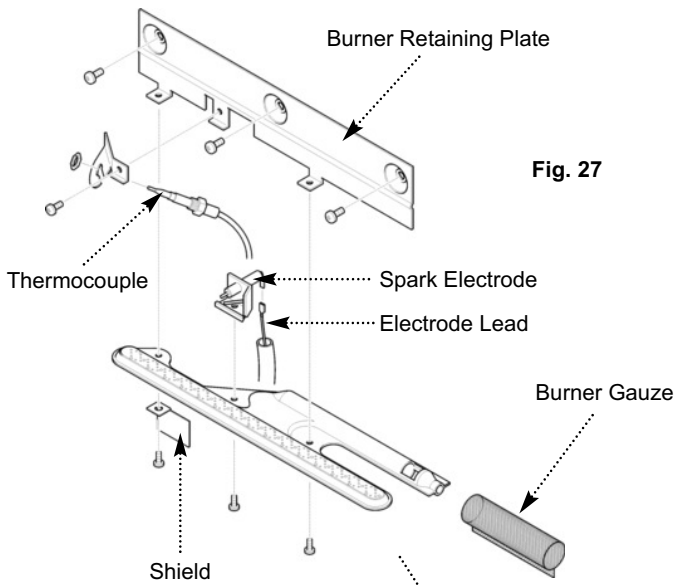

Fig. 28

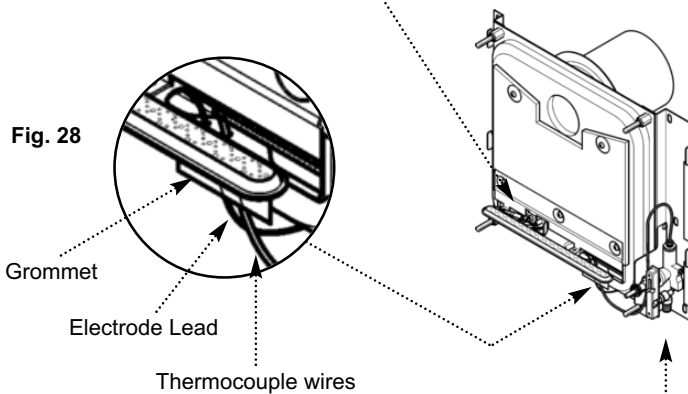
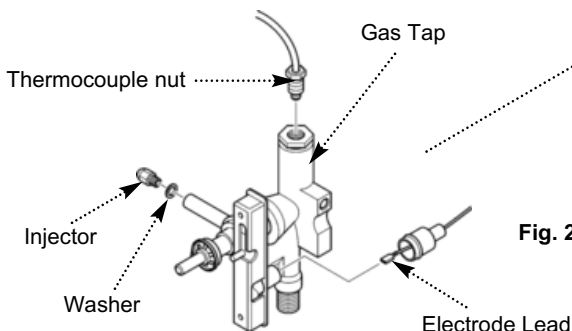

Fig. 29



## 8.0 Changing components on models with the Comfortstat control

### 8.1 Changing Components

1. Before changing any components please read Section 1.3 Important Information.
2. Turn off the gas supply and ensure that the appliance is cold.
3. Remove the case by easing upward and forward until it is clear of its retaining lugs (Fig. 30).
4. After changing any components re-commission the appliance

### 8.2 Gas Control Tap

1. Undo the heat exchanger retaining nuts and washers and draw the casting forward off the locating studs. Once clear of the studs the casting will need to be moved to the left to avoid the gas tap locating bracket.
2. Remove the three screws holding the burner retaining plate to the airbox, also remove the insulation and undo the thermocouple nut from the gas tap (Fig. 31 & 33).
3. Ease the thermocouple and electrode leads from the rubber grommet (Fig. 32).
4. Disengage the burner from the injector and pull the electrode lead off the spark electrode
5. Remove the supply pipe clamp and supply pipe from the gas tap.
6. Unscrew and remove the pipe that connects the gas tap to the injector carrier.
7. Unclip the thermostat phial.
8. Unscrew and remove the two screws that secure the gas tap to the gas tap locating bracket then ease the gas tap forward and clear of the bracket.
9. On re-assembly ensure that the airbox sealing grommet is correctly positioned and check for gas soundness.

Fig. 30

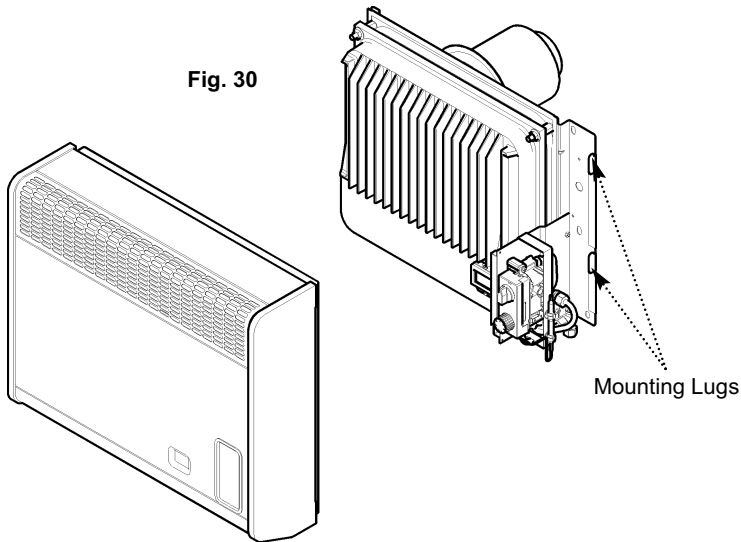

Fig. 31

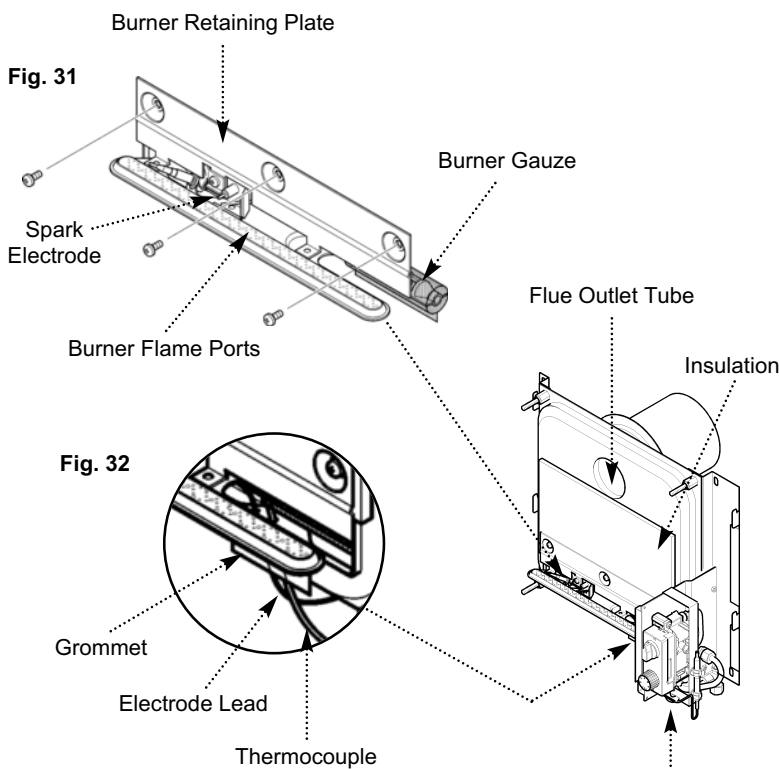

Fig. 32

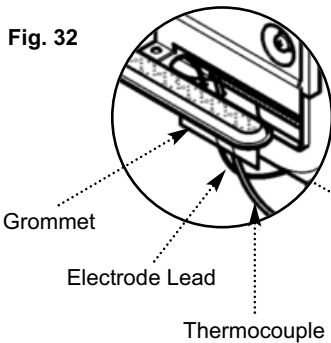
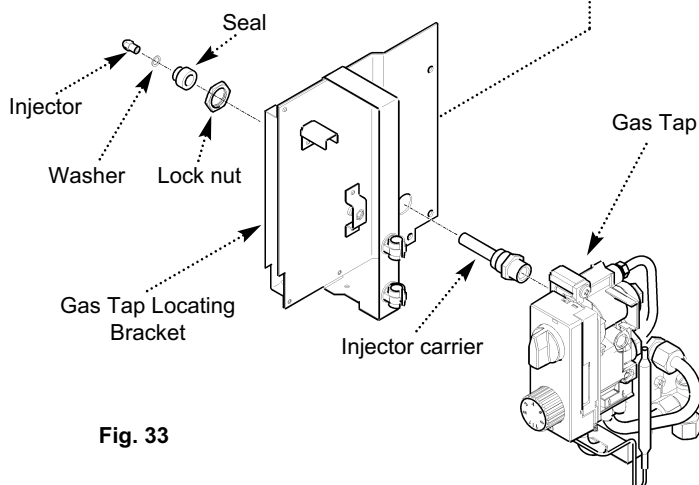

Fig. 33





## 8.0 Changing components on models with the Comfortstat control

### 8.3 Burner

1. Undo the heat exchanger retaining nuts and washers and draw the casting forward off the locating studs. Once clear of the studs the casting will need to be moved to the left to avoid the gas tap locating bracket. (Fig. 34).
2. Remove the three screws holding the burner retaining plate to the airbox, also remove the insulation and undo the thermocouple nut from the gas tap (Fig. 35 & 37).
3. Ease the thermocouple and electrode lead from the rubber grommet (Fig. 36).
4. Disengage the burner from the injector and pull the electrode lead off the spark electrode (Fig. 35).
5. Remove the intake gauze from the burner inlet and undo the screws securing the burner to its' retaining plate, noting the position of the shield at the left hand side (Fig. 35).
6. Undo the screw securing the spark electrode to the burner. Fit the electrode to the new burner (Fig. 35).
7. Fit the intake gauze to the burner inlet ensuring that it covers the primary aeration hole (Fig. 35).
8. Reassemble in reverse order of dismantling.

### 8.4 Injector

1. Remove the burner as described in sections 8.3.1 to 8.3.4.
2. Undo the injector and sealing washer, retaining the washer for use with the new injector. If the washer is damaged it must be replaced (Fig. 37).
3. Reassemble in reverse order of dismantling.

### 8.5 Thermocouple

1. Remove the burner as described in sections 8.3.1 to 8.3.4.
2. Undo the nut retaining the thermocouple tip to the burner bracket and withdraw the thermocouple.
3. Bend the new thermocouple in a similar manner to the one removed. Avoid any sharp bends.
4. On reassembly ensure that the airbox sealing grommet is correctly positioned.

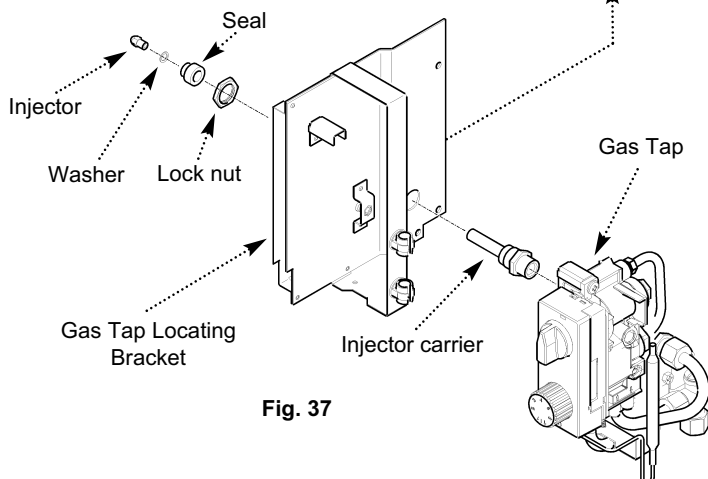
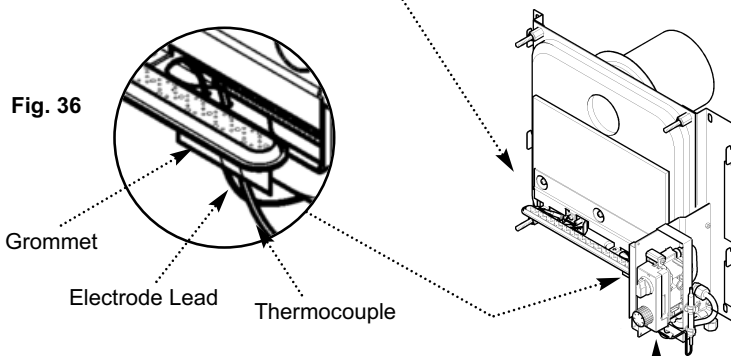
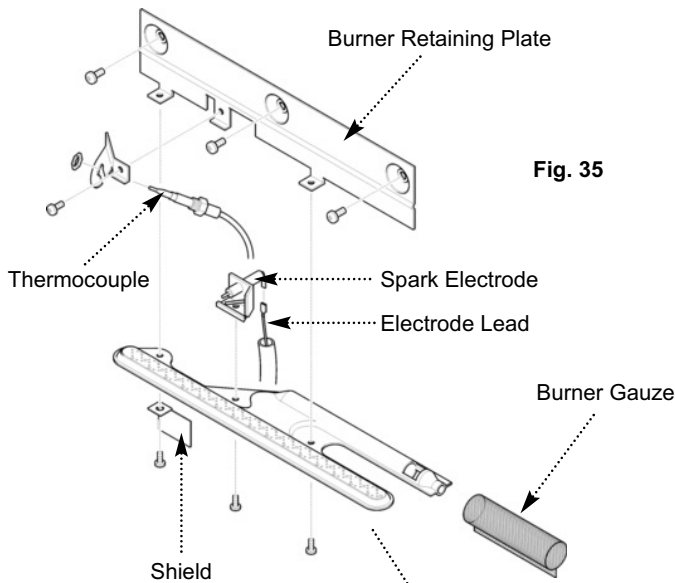
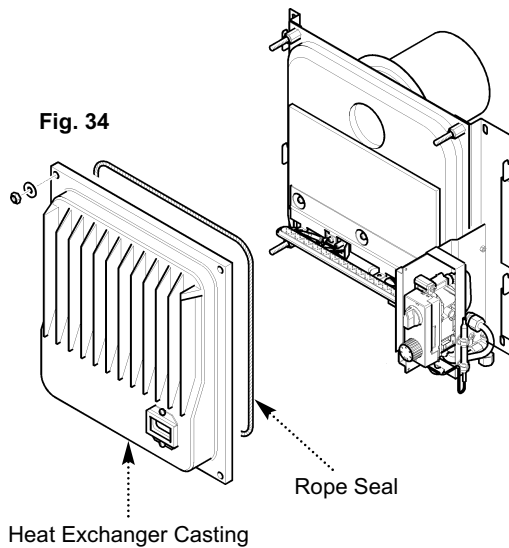

Ensure all installation criteria have been satisfied before performing Fault Finding (e.g. flue terminal position).

**8.0 Fault Finding**

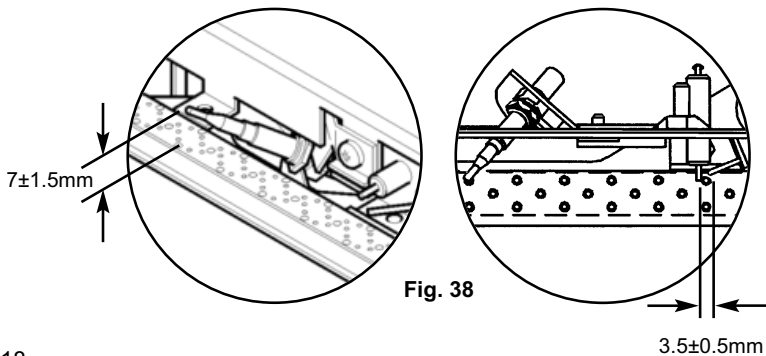
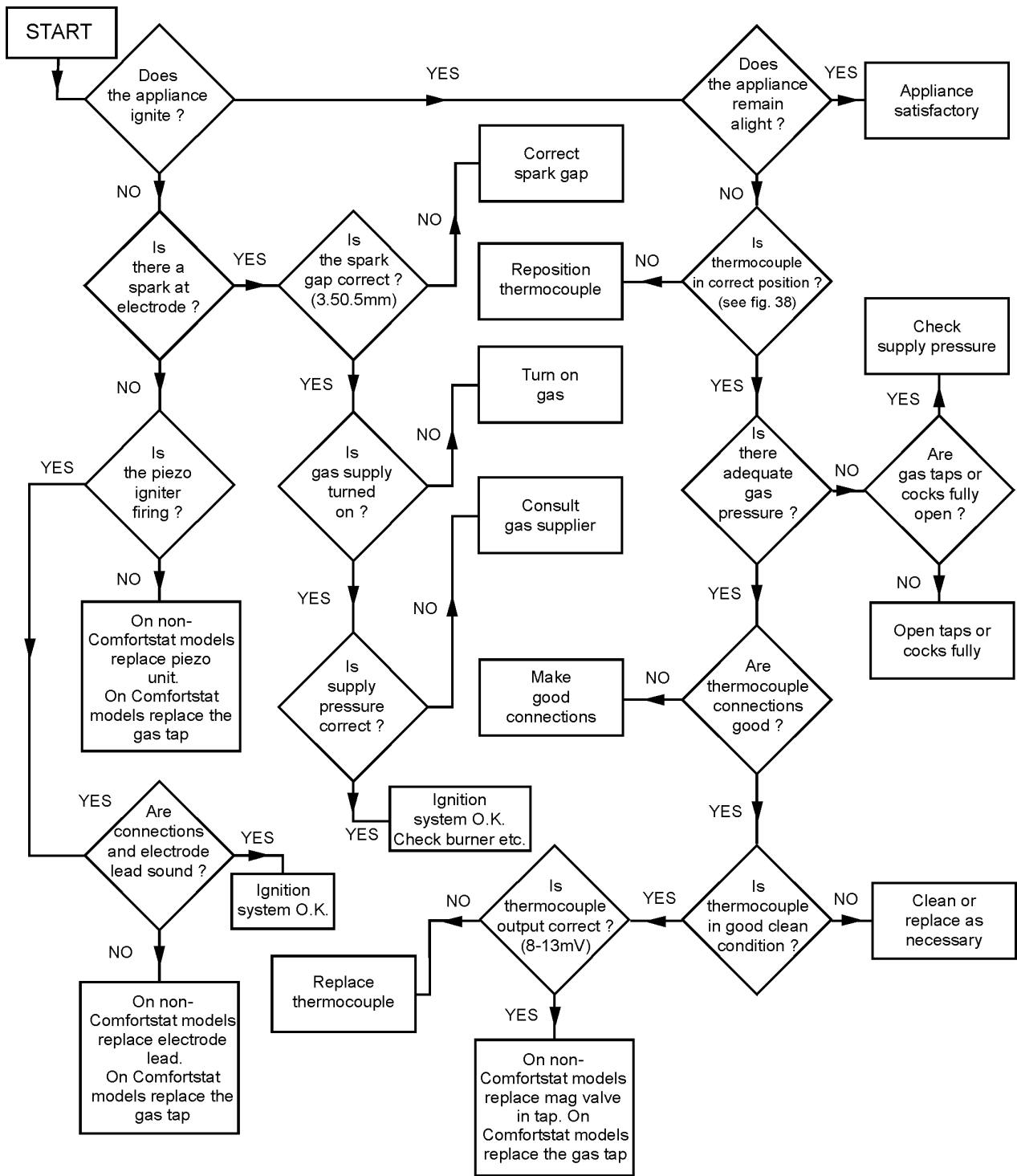

## 9.0 Short parts list

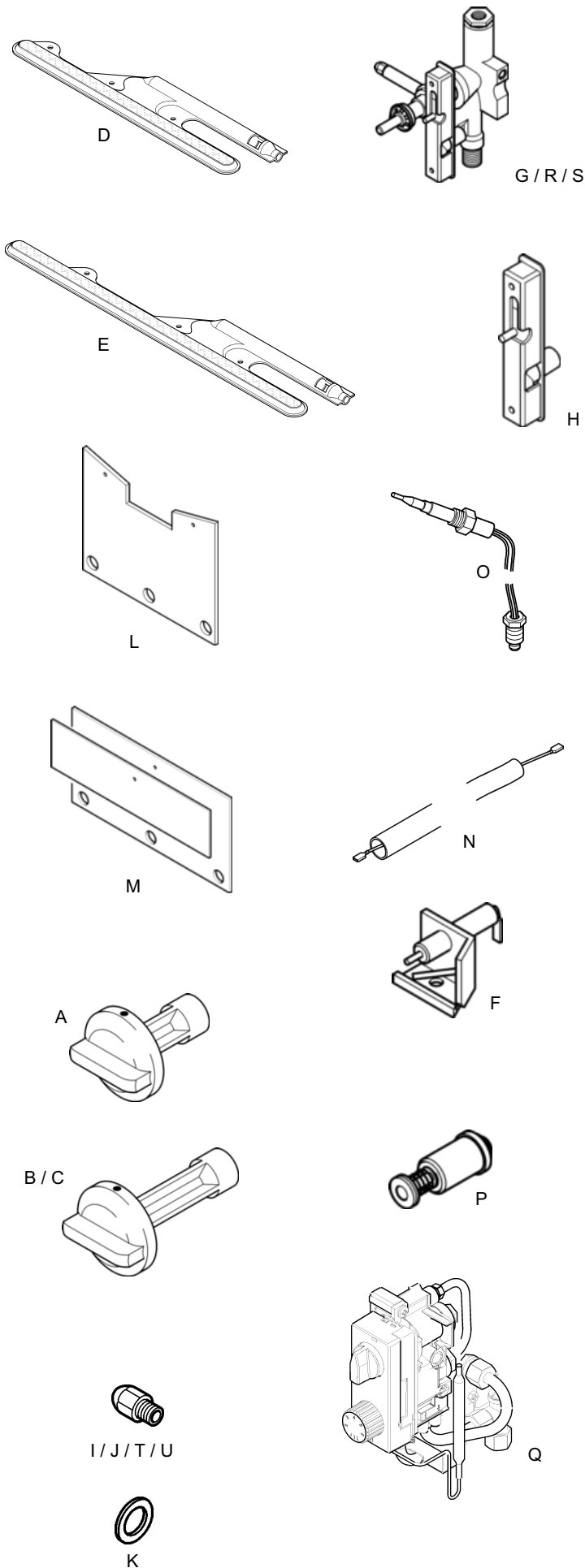

Key No.	G.C. No.	Description	Manufacturers Part No.
A	E26513	Knob Control (F 5 / F 5S) Grey	243262
	205887	Beige	234637
B	E26568	Knob Control (F 8S) Grey	243261
	205894	Beige	234643
C	E94629	Knob Control (F 8ST) Beige	3002698
D	205837	Burner (F 5 / F 5S)	224041
E	205864	Burner (F 8S / F 8ST)	223963
F	205873	Electrode Spark	223940
G	E01357	Igniter/Gas Tap (F 5 / F 5S)	243194
	E01358	Igniter/Gas Tap (F 8S)	243202
H	393734	Piezo Igniter/Generator	042941
I	381941	Injector (F 5 / F 5S)	224047
J	381942	Injector (F 8S / F 8ST)	224104
K	205791	Washer (For injector)	082365
L	205844	Insulation (F 5 / F 5S)	224048
M	E01359	Insulation (F 8S / F 8ST)	223971
N	155654	Lead Electrode (For models not fitted with Comfortstat control)	043043
O	E01360	Thermocouple	243215
P	384248	Tap Mag Unit (Not F 8ST)	082462
Q	E94622	Thermostat / Gas Control	3002927

### For LPG models only

R	E26556	Igniter / Gas Tap Assy. LPG (F 5 / F 5S)	243195
S	E26574	Igniter / Gas Tap Assy. LPG (F 8S)	243203
T	E26522	Injector LPG (F 5 / F 5S)	243295
U	E23577	Injector LPG (F 8S)	243296



---

## Owner Guide.

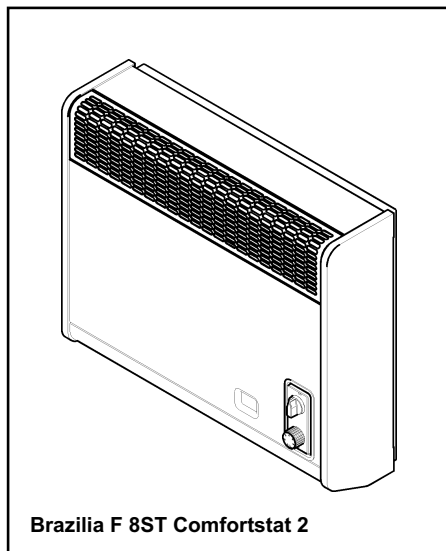
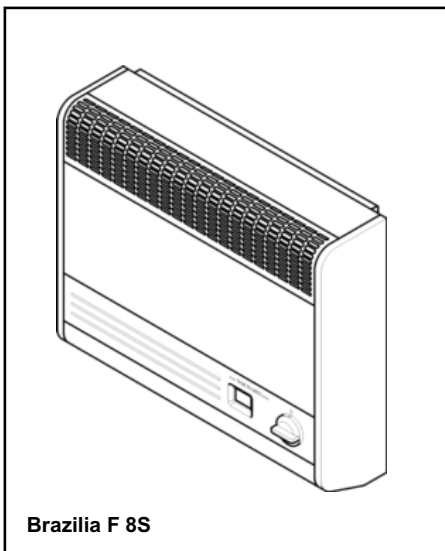
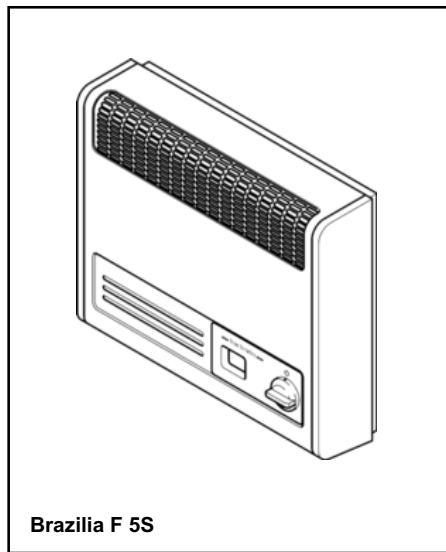
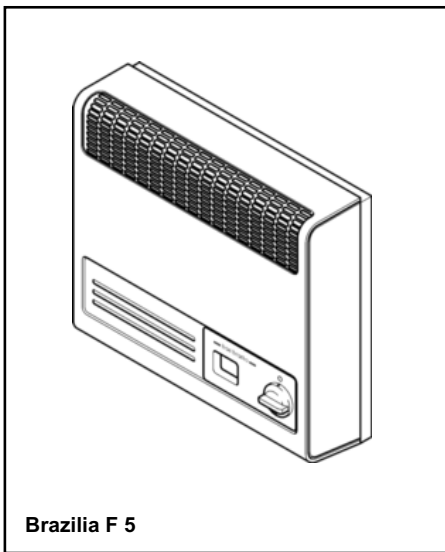

### Notice

#### Discolouration of wall surfaces

Most heating appliances generate warm air convection currents and transfer heat to any wall surface against which they are situated.

Some soft furnishings (such as blown vinyl wallpapers) may not be suitable for use where they are subject to temperatures above normal room levels and the manufacturer's advice should be sought before using this type of wall covering adjacent to any heating appliance.

The likelihood of wall staining from convected air currents will be increased in environments where high levels of tobacco smoke or other contaminants exist.

## 1.0 Warnings

**This appliance must be installed in accordance with the manufacturers instructions and the rules in force.**

### 1.1 Regulations, Standards and Law.

The installation must be in accordance with this guide. For the user's protection, in the United Kingdom it is the law that all gas appliances are installed by competent persons in accordance with the current edition of the Gas Safety (Installation and Use) Regulations. Failure to install the appliance correctly could lead to prosecution. GAS SAFE REGISTER and CORGI require their members to work to recognised standards.

In the United Kingdom the installation must also be in accordance with:

All the relevant parts of local regulations.

The relevant parts of the current editions of the following British Standards:-

BS 5440 Part 1-	Installation of flues
BS 5871 Part 1-	Installation - Gas fires
BS 6891-	Installation of low pressure gas pipework of up to 35mm (R1 ¼) in domestic premises (2nd family gas) - specification.

- In England and Wales, the current edition of the Building Regulations issued by the Department of the Environment and the Welsh Office.
- In Scotland, the current edition of the Building Standards (Scotland) Regulations issued by the Scottish Executive.
- In Northern Ireland, the current edition of the Building regulations (Northern Ireland) issued by the Department of the Environment for Northern Ireland.
- In the republic of Ireland the installation must be carried out by a competent person and also conform to the relevant parts of:

a) The current edition of IS 813 "Domestic Gas Installations"

b) All relevant national and local rules in force.

Where no specific instructions are given, reference should be made to the relevant British Standard Code of Practice.

## Owner Guide

### 1.2 Considerations for timber framed buildings.

Installation to a timber-framed building should be in accordance with the relevant sections of The Institute of Gas Engineers publication IGE/UP/7 "Gas installations in timber frame buildings".

Please note that advice should be sought before installing in a timber frame building since the alterations required may nullify any NHBC cover relating to the property. If in doubt, guidance should be requested from your local authority planning or building department.

**Under no circumstances is the fire to be recessed into timber frame constructions.**

### 1.3 Ventilation requirements.

No special ventilation bricks or vents are required into the room containing the appliance.

### 1.4 Fireguard requirements.

A fireguard complying with BS 8423 should be fitted for the protection of young children, the elderly, the infirm and pet animals.

### 1.5 Room considerations.

It is advisable that combustible fabrics such as curtains are not fitted above the fire. If, however, this is unavoidable, the extreme bottom edge of the fabric must be at least 780mm above the base of the fire.

### 1.8 In case of Gas leaks

**If a gas leak is found or suspected**, immediately turn off the gas supply at the meter or tank as appropriate and contact your Installer, Gas Emergency (under 'Gas' in the phone directory) or the gas supplier.

### 1.9 Servicing your Appliance

For reasons of safety and economy your appliance should be serviced annually. Your Installer or Gas Service provider will be able to advise you.

**The external flue terminal must be kept free from obstruction at all times.**

**If the terminal is less than 2m (6ft.) from ground level, a balcony or other place to which any person has access a suitable terminal guard must be fitted.**

### Gas Emergency Contact numbers:

- England, Wales and Scotland	0800 111 999
- Northern Ireland	0800 002 001
- Republic of Ireland	1850 20 50 50

## 2.0 Introduction & Operation

### 2.1 Introduction

1. Your Brazilia F is a room sealed gas convector heater. This means that the gas burning section is sealed from the room in which it is installed. It is connected to a circular flue terminal outside the building. This terminal is the inlet for air required to burn the gas and also the outlet for the flue gases.

### 2.2 Operating units that are not fitted with the Comfortstat control.

1. The appliance is controlled by a knob which is positioned at the lower right on the front of case (Fig. 1).

The knob has five positions.

Position ●	OFF
Position I	LOW
Position ★	IGNITION
Position II	MEDIUM
Position III	HIGH

2. **To light the appliance** (Fig 2a): At the OFF (●) position push in the control knob as far as possible and still pushing in **slowly** turn anti-clockwise to the ignition position (★) to light the burner. Turning the control knob slowly allows gas to enter the burner ready for ignition. Keep the knob pushed in for 20 seconds and the burner should remain alight. If not, repeat the sequence.

**NOTE:** Under extreme wind conditions more than one attempt to light the appliance may be required.

3. Once lit, the control knob can be altered to any of the three heat settings.

4. When first lit after installation some smells are likely to be emitted. These will quickly clear away with use.

**NOTE:** If the appliance goes out at any time wait 3 minutes and repeat the procedure. When changing from one setting to another the knob should always be pushed in slightly.

5. **To turn the appliance off:** Push the knob in slightly and turn to the OFF (●) position.

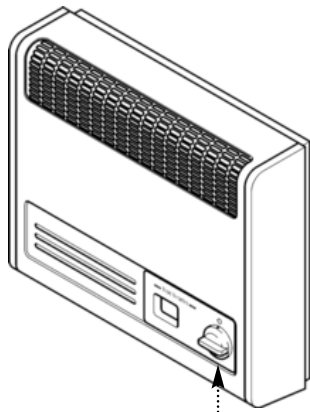

Fig. 1

Control Knob

Relative positions of markings on side of control knob.

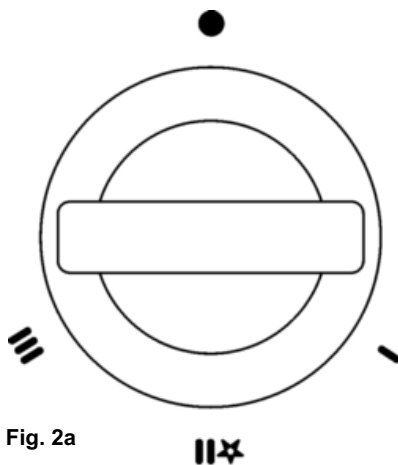

Fig. 2a

Position ● - OFF  
 Position I - LOW  
 Position ★ - IGNITION  
 Position II - MEDIUM  
 Position III - HIGH

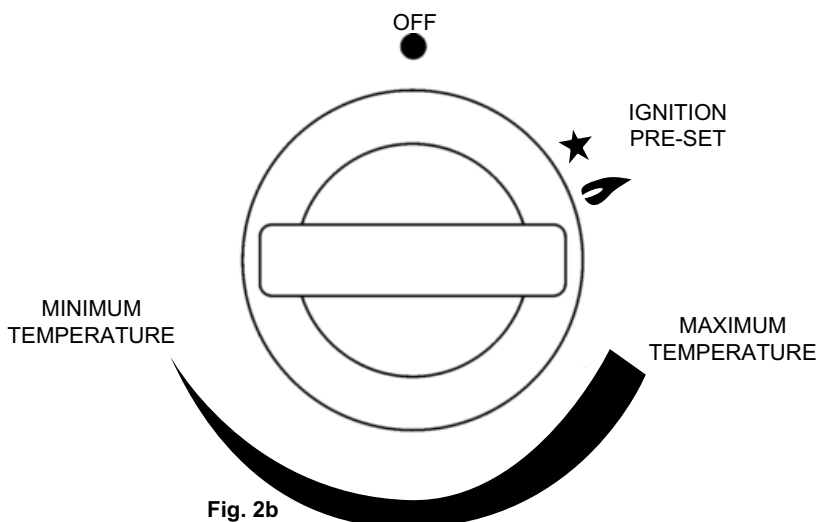

Fig. 2b

**2.0 Introduction & Operation**

**2.3 Operating units fitted with the Comfortstat control.**

1. The appliance is controlled by two knobs which are positioned at the lower right on the front of case (Fig. 3).  
The upper knob has four positions.

Position ●	OFF
Position ✦	IGNITION
Position ◐	LOW
Position ◑	HIGH

2. **To light the appliance** (Fig 3a): At the OFF (●) position push the upper control knob as far as possible and still pushing in **slowly** turn anti-clockwise to the ignition position (✦) to light the burner. Turning the control knob slowly allows gas to enter the burner ready for ignition. Keep the knob pushed in for 10 seconds and the burner should remain alight. If not, repeat the sequence.

**NOTE:** Under extreme wind conditions more than one attempt to light the appliance may be required.

3. Once lit, the control knob can be altered to the High or Low heat settings.

4. When first lit after installation some smells are likely to be emitted. These will quickly clear away with use.

**NOTE:** If the appliance goes out at any time wait 3 minutes and repeat the procedure. When changing from one setting to another the knob should always be pushed in slightly.

5. **To adjust the thermostat setting** (Fig 3b): The lower control knob alters the temperature setting, the knob has seven positions.

6. **To turn the appliance off:** Push the knob in slightly and turn to the OFF (●) position.

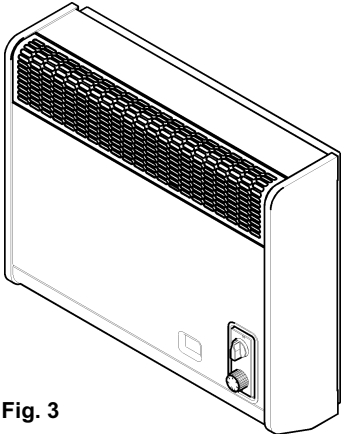

Fig. 3

Control Knob

Relative positions of markings on side of upper knob.

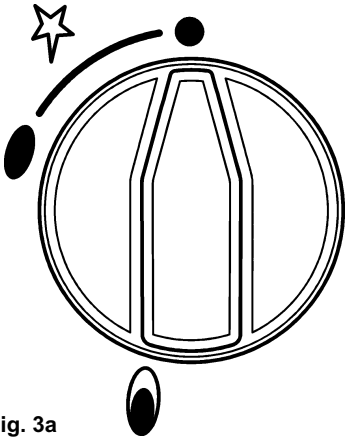

Fig. 3a

- Position ● - OFF
- Position ✦ - IGNITION
- Position ◐ - LOW
- Position ◑ - HIGH

Markings on lower knob.

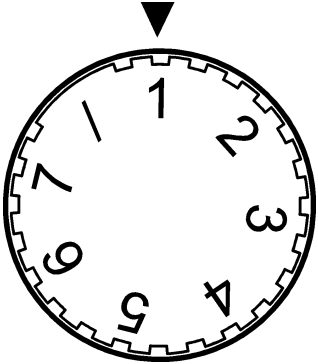

Fig. 3b

### 3.0 Cleaning & Clearances

---

#### 3.1 Cleaning the Appliance

1. When cold the appliance may be cleaned with a damp cloth and wiped with a soft duster. Do not use abrasive cleaning agents, wax or spray polish.

---

#### 3.2 Clearances

1. Internally the appliance must not be fitted under a shelf or sill that projects more than 150mm (6in.)
  2. Curtains or a shelf must not be closer to the top of the outer case than 140mm (5<sup>1</sup>/<sub>2</sub>in) for F 5 & F 5S or 89mm (3<sup>1</sup>/<sub>2</sub>in) for F 8S & F 8ST models.
  3. The minimum side clearances from any wall or fixed furniture are:-  
Left hand side 45mm (1<sup>3</sup>/<sub>4</sub>in)  
Right hand side 57mm (2<sup>1</sup>/<sub>4</sub>in)
-



## 4.0 Spares & Running Costs

---

### 4.1 Spare Parts

1. If spare parts are required they can be obtained through GDC Group Service Dept. Please read section 5.
  2. Always quote the appliance model name and G.C. number. The G.C. number can be found on page 2 of these instructions.
  3. A "Special Needs Adaptor" is available for use with the Brazilia F. This is designed for customers suffering from arthritis or similar conditions and provides the user with extra leverage when operating the control knob. It is available from Spares Stockists.
- 

### 4.2 Running Costs

1. The running cost of the appliance is quoted in kilowatt hours (kWh). The price per kilowatt hour varies and is shown on your gas bill.
2. The table below shows the approximate time taken by the appliance to consume 1 kWh of energy on minimum and maximum rates.

	<b>F 5 &amp; 5S</b>	<b>F 8S</b>	<b>F 8ST</b>
<b>High</b>	29 mins.	19 mins.	19 mins.
<b>Low</b>	1 hour 8 mins.	47 mins.	40 mins.

---

<b>Troubleshooting</b>		
<b>Symptom</b>	<b>Cause</b>	<b>Corrective Action</b>
Appliance will not ignite	No ignition spark can be seen or heard	Ensure the control knob is in the 'off' position and turned anti-clockwise to ignition position.
	Control knob is not in low / minimum position	Ensure control knob is set at low / minimum position
	Rotating control knob too fast	<b>Very Slowly</b> , rotate control knob anti-clockwise to ignition position.
	Control knob not ' <b>fully</b> pushed in' for sufficient period of time	Keep the control knob pushed in for 20 secs and the burner should remain alight. If not, repeat the sequence.
	Cold Start Up of Appliance / Extreme wind conditions	<b>Very Slowly</b> , rotate control knob anti-clockwise to ignition position. Keep the control knob pushed in for 30-40 secs and the burner should remain alight. If not, repeat the sequence.
Appliance is Cutting Out	Cutting out while in operation	Wait 3 minutes, return control knob to off position and repeat the ignition sequence.
	Sudden adjustments to control knob.	Ensure the control knob is gradually adjusted and not suddenly turned up.

### 6.0 Warranty and Service

#### 6.1 Standard Warranty Terms & Conditions

The warranty is for 12 months subject to contract.

In the United Kingdom servicing can be carried out either by a **GDC** approved service engineer or a **GAS SAFE REGISTER** engineer.

Outside of the United Kingdom servicing can be carried out either by a **CORGI** or **GAS SAFE REGISTER** engineer.

It is a requirement of the warranty that the fire **MUST** have an annual service (every 12 months) in accordance with the installation and servicing instructions, performed by a **GAS SAFE REGISTER** engineer, (CORGI or GAS SAFE REGISTER outside of UK). **The frequency of service will depend on usage!**

#### 6.2 Benchmark Checklist/Service Record

Please ensure that the installer has fully completed the Benchmark Checklist on the inside back pages of the installation instructions supplied with the product and that you have signed it to say that you have received a full and clear explanation of its operation. The installer is legally required to complete a commissioning checklist as a means of complying with the appropriate Building Regulations (England and Wales).

Installations carried out in England and Wales must be notified to Local Area Building Control either directly or through a Competent Persons Scheme. A Building Regulations Compliance Certificate will then be issued to the customer who should, on receipt, write the Notification Number on the Benchmark Checklist.

The filled in Benchmark Checklist/Service Record by the installer will be required in the event of any warranty (UK and Ireland installation).

After servicing, complete the relevant "Service Interval Record" section of the Benchmark Checklist located on the inside back pages of this document.

#### 6.3 Our promise to you

If you experience a fault with your new fire, we aim to provide a safe and high quality repair service supported by our dedicated national network of highly skilled engineers. If your installer can't resolve the problem for you, we will do everything we can to get an engineer out to you as quickly as possible. Nothing in this warranty will affect your statutory rights.

#### 6.4 What you need to do if you experience a problem with the operation of the fire:

- Please review the troubleshooting guide in this booklet.
- You should always contact your installer first, because the cause of the fault may not be related to the fire.
- If your installer confirms that the fault is with the fire and they can't repair it, our friendly customer service team is on hand to help.
- Simply call our GDC Group Technical helpline on

In the United Kingdom;

Telephone **0844 879 35 88**

In the Republic of Ireland

Telephone **01 842 8222**

When calling the GDC Group customer helpline, it would be helpful if you could have the following information to hand:-

1. Fire serial number - (See figure 4).
2. Date of installation
3. Your installer name and address details
4. Fire make and model number
5. Proof of purchase (if you do not have the fire serial number)
5. Annual Service record details\*

**\*Note: details 1 – 5 should be recorded as part of the Benchmark Checklist / Service record at the end of this guide, Pages 28 and 29.**

#### 6.5 What this warranty covers

Free of charge repair or replacement of components found to be of faulty manufacture.

Free of charge replacement of the complete unit providing the failure is related to a manufacturing fault that cannot be repaired or is uneconomic to repair.

#### 6.6 What this warranty does not cover

Repairs to fires which haven't been installed and commissioned properly and as set out in the installation instructions.

Faults caused by inadequate supply of gas or electricity (where applicable).

Reimbursement of any third party repair or replacement costs that we haven't been told about or agreed with you in advance.

Compensation or consequential losses (e.g. loss of earnings, business losses, stress and inconvenience) arising from a production breakdown, including repair delays caused by factors outside our reasonable control.

### 7.0 Warning

- Do not obstruct any grilles or air inlets/outlets.
- Do not hang any clothes etc. over this appliance.
- This appliance should be installed and serviced by a Gas Safe registered installer.
- After initial lighting some fumes may occur for a short period. These are harmless and will quickly clear away during use.
- Parts of the grille or casing will become hot during use. A fireguard conforming to BS8423 should be used for the protection of the elderly, infirm, young children or pets.
- For further information see the installation and owner guide.

**GDC Group Ltd. Millbrook House,  
Grange Drive, Hedge End,  
Southampton,SO30 2DF,  
U.K.**

# Owner Guide

The following pages are all to be completed by the installer:

## GAS FIRE COMMISSIONING CHECKLIST

This Commissioning Checklist is to be completed in full by the competent person who commissioned the gas fire as a means of demonstrating compliance with the appropriate Building Regulations and then handed to the customer to keep for future reference.

Failure to install and commission according to the manufacturer's instructions and complete this Benchmark Commissioning Checklist will invalidate the warranty. This does not affect the customer's statutory rights.

Customer name:	Telephone number:
Address:	
Gas Fire make and model:	
Gas Fire serial number: <input type="text"/>	
Commissioned by (PRINT NAME):	Gas Safe register number:
Company name:	Telephone number:
Company address:	
Commissioning date:	
Building Regulations Notification Number (if applicable):	

Site Requirements	Yes	N/A
Was the chimney checked to ensure it only serves one flue/fire, has no obstructions and is continuous?		
Has any debris at the base of the chimney been removed?		
For brick chimney installations is there enough depth for 12 litres of debris, or precast flues 2 litres of debris? (see instructions for debris gap details)		
Have damper and register plates been removed or locked in the fully open position ensuring correct size of flue is maintained?		
If previously used for solid fuel has the chimney been thoroughly swept?		
If the chimney is pre-cast has the inside of the flue been checked for extruded cement / sealant which must be removed?		
Has the fire place been checked for under-floor air supply which must be sealed off?		
Has the chimney been inspected prior to fitting the gas fire to ensure that it is in good condition?		
Has the structure of the chimney been checked for leakage using a smoke pellet test? (See BS5440-1 for details).		
<b>Ventilation</b>		
Does the installation require any additional ventilation requirements as detailed in the manufacturer's instructions?		
<b>Hearth Requirements- where fitted</b>		
Is the hearth constructed from non -combustible material?		
Is the hearth a minimum of 12mm thick with a minimum floor to top surface of 50mm?(BS5871) or as per manufacturer's instructions?		
Is the hearth for open fronted fires a minimum of 760mm wide and has 300mm projecting from the fire opening (BS6871) or to manufacturer's instructions?		
Mounting height (where applicable) has the fire been installed to the correct mounting height- as per manufacturer's instructions?		
<b>Firebox and Fuel Bed</b>		
Has the fuel bed, coals, pebbles etc. been fitted to manufacturer's instructions?		
<b>Gas Supply</b>		
Has an isolation tap/restrictor inlet elbow been fitted for servicing?		
Has the gas supply been thoroughly purged prior to connection to remove any debris?		
Has a gas tightness test been completed prior to breaking into the gas supply and following completion of installation?(IGEM/UP/1B)		
Record burner gas pressure reading? If only the supply pressure is available a gas rate must be undertaken.(GSIUR REG26/9C)		
Record dynamic inlet gas pressure (working pressure) reading (all gas appliances running)		
<b>Spillage test</b>		
Installation passes smoke match test with any extractor fans turned on (see manufacturer's instructions)		
<b>Installation</b>		
Has the gas fire been installed and commissioned in accordance with manufacturer's instructions?		
Has the fire been installed with the correct clearance to combustible materials, as per manufacturer's instructions?		
The operation of the appliance and controls have been demonstrated to the customer including battery replacement where applicable?		
The manufacturer's literature, including Benchmark Checklist and Service record has been explained and left with the customer?		
Has the appliance been registered with the Local Authority as detailed on the Gas Safe web site and is a legal requirement and forms part of the warranty?		
Customer's Signature: (To confirm satisfactory demonstration and receipt of manufacturer's literature)	Commissioning Engineer's Signature:	

\*All installations in England and Wales must be notified to be Local Authority Building Control (LABC) either directly or through a Persons Scheme. A Building Regulations Compliance Certificate will then be issued to the customer.



## SERVICE RECORD

It is essential that your gas fire is serviced regularly and that the appropriate Service Interval Record is completed.

### Service Provider

Before completing the appropriate Service Record below, please ensure you have carried out the service as described in the manufacturer's instructions. Always use the manufacturer's specified spare part when replacing controls.

<b>SERVICE 01</b>	Date:
Engineer name:	
Company name:	
Telephone No:	
Gas safe register No:	
Comments:	
Signature	
<b>SERVICE 02</b>	Date:
Engineer name:	
Company name:	
Telephone No:	
Gas safe register No:	
Comments:	
Signature	
<b>SERVICE 03</b>	Date:
Engineer name:	
Company name:	
Telephone No:	
Gas safe register No:	
Comments:	
Signature	
<b>SERVICE 04</b>	Date:
Engineer name:	
Company name:	
Telephone No:	
Gas safe register No:	
Comments:	
Signature	
<b>SERVICE 05</b>	Date:
Engineer name:	
Company name:	
Telephone No:	
Gas safe register No:	
Comments:	
Signature	
<b>SERVICE 06</b>	Date:
Engineer name:	
Company name:	
Telephone No:	
Gas safe register No:	
Comments:	
Signature	
<b>SERVICE 07</b>	Date:
Engineer name:	
Company name:	
Telephone No:	
Gas safe register No:	
Comments:	
Signature	
<b>SERVICE 08</b>	Date:
Engineer name:	
Company name:	
Telephone No:	
Gas safe register No:	
Comments:	
Signature	
<b>SERVICE 09</b>	Date:
Engineer name:	
Company name:	
Telephone No:	
Gas safe register No:	
Comments:	
Signature	
<b>SERVICE 10</b>	Date:
Engineer name:	
Company name:	
Telephone No:	
Gas safe register No:	
Comments:	
Signature	



# Owner Guide

**This page is to be completed by the installer:**

Installer Details (Block Capitals)

Installer Name	
Gas Safe Register or Corgi Registration Number.	
Company Name.	
Company Address	
Company Telephone number	
Company Fax number	

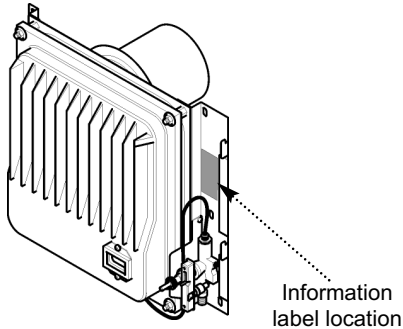

**Fig. 4**

Product Code

□	□	□	□	□	□	□	□
---	---	---	---	---	---	---	---

Serial number (Can be found on information label - See figure 4)

□	□	□	□	□	□	□	□	□	□	□	□	□	□	□
---	---	---	---	---	---	---	---	---	---	---	---	---	---	---

SERIAL NUMBER LABEL  
TO BE AFFIXED HERE

A LABEL CONTAINING  
THE SERIAL NUMBER  
MAY HAVE BEEN  
PLACED INSIDE THIS  
BOX.

Name

B	R	A	Z	I	L	I	A	F	5	(Please tick)	<input type="checkbox"/>	
B	R	A	Z	I	L	I	A	F	5	S	<input type="checkbox"/>	
B	R	A	Z	I	L	I	A	F	8	S	<input type="checkbox"/>	
B	R	A	Z	I	L	I	A	F	8	S	T	<input type="checkbox"/>

Date of Installation

□	□	□	□	□	□
D	D	M	M	Y	Y