

Creda

OPERATING INSTRUCTION MANUAL

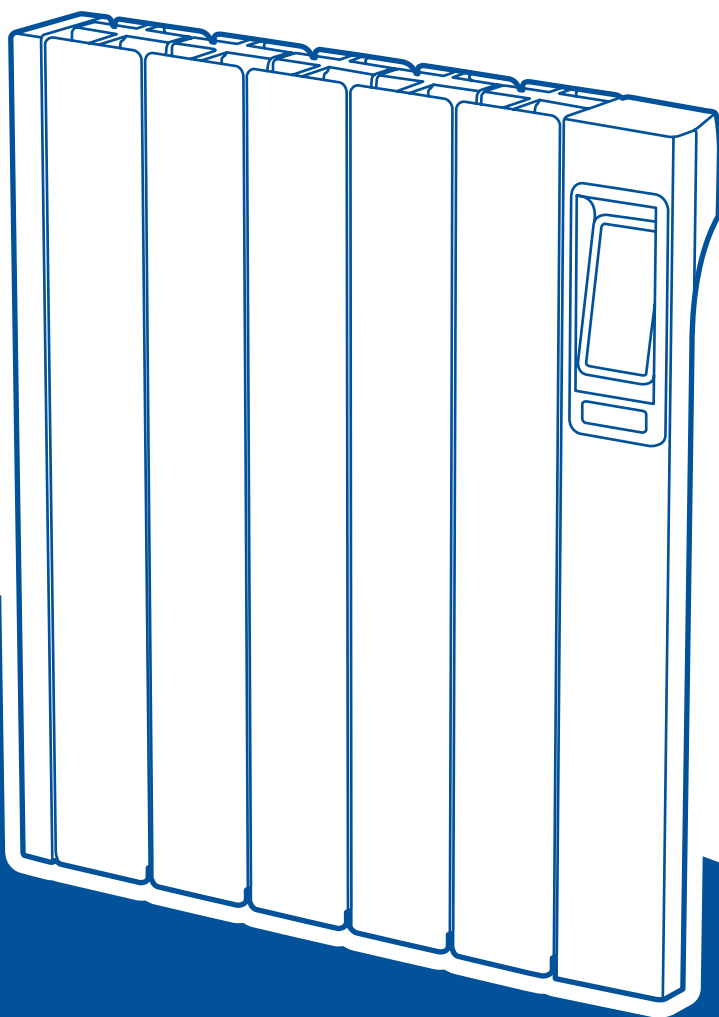

- ▶ Integrated 7-day timer
- ▶ Colour-changing LCD display
- ▶ Adaptive start
- ▶ Open window detection

Creda Aluminium Radiator

Models: CAR 033 / CAR 050 / CAR 075 / CAR 100 / CAR 150 / CAR 200

These instructions should be read carefully and retained for future use. Note also the information presented on the appliance.



IMPORTANT
THESE INSTRUCTIONS SHOULD BE READ CAREFULLY AND RETAINED FOR FUTURE REFERENCE.

CAUTION:

FAILURE TO FOLLOW THESE INSTRUCTIONS MAY CAUSE INJURY AND/OR DAMAGE AND MAY INVALIDATE YOUR CREDA GUARANTEE

IMPORTANT SAFETY ADVICE

When using electrical heaters, basic precautions should always be followed to reduce the risk of fire, electrical shock, and injury to persons, including the following:

IMPORTANT – The wall bracket supplied with the heater must be used.

WARNING - Do not allow this heater to come into contact with water. Do not use this heater in the immediate surroundings of a bath, a shower or swimming pool

IMPORTANT - If the heater is installed in a room containing a bath or shower, in accordance with the current wiring regulations BS7671, minimum clearances and IP zone requirements must be adhered to, including protections via RCD. Heaters used in these settings must be connected to the fabric wiring of the building via a suitable connection/isolation device.

WARNING - This heater is suitable for normal domestic household purposes and should not be used in any other type of environment. This product should only be used in the country where it was purchased and should only be purchased from a recognised commercial retailer.

Do not use outdoors.

Do not locate the heater immediately below a fixed electrical point i.e. socket outlet.

WARNING - In order to avoid overheating, do not cover or obstruct the heater. Do not place material or garments on the heater, or obstruct the air circulation around the heater, for instance by curtains or furniture, as this could cause overheating and a fire risk. NEVER cover or obstruct in any way the heat outlet slots at the top of the heater or the air inlet slots in the base of the heater.



The heater carries a warning 'DO NOT COVER' to alert the user to the risk of fire that exists if the heater is accidentally covered.

CAUTION - Some parts of this product can become very hot and cause burns. Particular attention has to be given where children and vulnerable people are present.

WARNING - This heater must not be used by children below 8 years of age. Children under 3 years of age must not come into contact with this heater and should be kept under continual supervision when in its vicinity. Children over 8 years of age and persons lacking of knowledge or experience or with reduced physical, sensory or mental capabilities may use this heater only with appropriate supervision and instruction concerning these Operating and Safety instructions.

IMPORTANT - Remember to observe all safety warnings and precautions when operating the heater on the automatic or timer modes, either attended or unattended.

Note that due care and consideration must be taken when using this heater in series with the built-in thermal control, program controller, timer or any other device that switches on the heat automatically, since a fire risk exists when the heater is accidentally covered or displaced.

CAUTION - Do not use if the heater's mains power lead is damaged.

WARNING - Servicing and product repairs should only be undertaken by the manufacturers approved service agent or a similarly trained or qualified person, using only exact manufacturer approved spare parts.

WARNING - This heater must be earthed

The electrical installation must be carried out by a suitable qualified or trained electrician, and be in strict accordance with the current wiring Regulations BS7671 for Electrical Equipment in Buildings. The wires in this mains lead are coloured in accordance with the following code:

GREEN AND YELLOW:	EARTH
BLUE:	NEUTRAL
BROWN:	LIVE

The heater is fitted with a length of flexible cable type H05VV-F size 3 x 1.0mm² for connection to the fixed wiring of the premises through a suitable double pole switched fused spur, with the fuse rated correctly for the appliance, positioned adjacent to the heater. A means for disconnection must be incorporated in the fixed wiring of the premises in accordance with the wiring regulations.

WARNING - This heater must not be connected to the electricity supply via an external switching device (such as a timer) or a circuit that is regularly switched on and off by the utility supplier. Failure to follow this warning could result in the heater's thermal cut-off being inadvertently re-set and could create a fire hazard.

This heater is filled with a precise quantity of special oil. Repairs requiring opening of the oil container are only to be made by the manufacturer or the manufacturer's service agent who should be contacted if there is an oil leakage. Regulations concerning the disposal of oil when scrapping the heater have to be followed.

If the supply cord is damaged it must be replaced by the manufacturer or approved service partner

Please note that lit cigarettes, candles and oil burners, combined with the convection effect of electric heaters can cause significant soot deposits to build up on the surface directly above and to the sides of the heater. This is not a fault of the heater. Extensive burning of candles or smoking in the operating environment of this product can produce heavy discolouration within a few months of use.

SAFETY - Overheat protection

For your safety this heater is fitted with a thermal cut-out. In the event that the product overheats for some reason, the cut-out prevents excessive temperatures on the product by cutting the power to the heater. Once the heater has cooled down, it will reset automatically, it will continue to cycle on and off automatically until the reason for overheating is removed. The display screen may flash red to indicate the product has overheated. To reset the display, remove the obstruction and hold Enter for 10 seconds.

General

The heater is designed for wall mounting using the wall bracket supplied. It should only be operated when in the upright position as shown - see **Fig. 1** and **Fig. 2**. All models are splash proof to IP24 standard and may be used in bathrooms, however not in the immediate vicinity of baths, showers, water connections, wash basins or swimming pools. Before connecting the heater check that the supply voltage is the same as that stated on the heater.

Wall Mounting

IMPORTANT - The wall bracket supplied with the heater must be used. The heater should be positioned observing the minimum clearances stated around the heater - see **Fig. 1** and **Fig. 2**.

DO NOT locate the heater immediately below a fixed socket outlet or connection box.

1. Remove wall mounting brackets from the protective packaging and locate the wall mounting template.
2. Using the template, drill and plug the mounting holes specific to your particular model - see **Fig. 3**.
3. Fix the top wall mounting brackets securely to the wall using the screws provided.
4. The bottom wall mounting brackets should be clipped onto the product and oriented correctly prior to mounting the product to the wall, - see **Fig. 3**.
5. The product can now be hung on the top wall mounting bracket then fixed in place by securing the bottom wall bracket(s) in place.

Wattage (W)		
Model(s)	Watt (kW)	A (mm)
CAR 033	0.33 kW	348
CAR 050	0.50 kW	508
CAR 075	0.75 kW	588
CAR 100	1.00 kW	668
CAR 150	1.50 kW	908
CAR 200	2.00 kW	1068

Fig. 1

Minimum mounting clearance

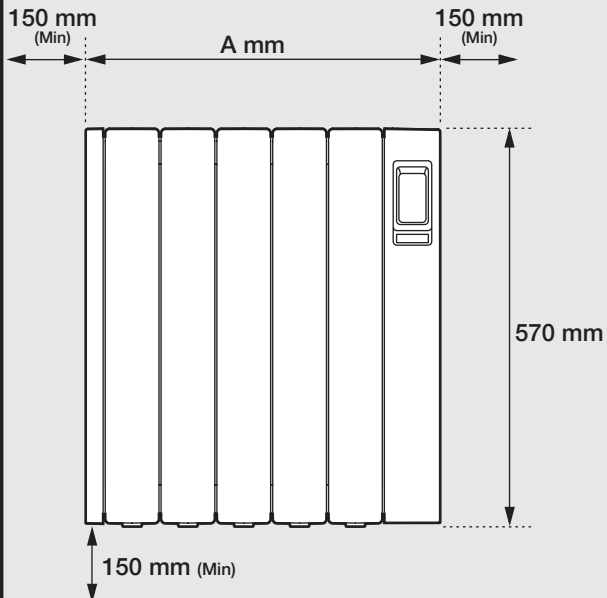

Fig. 2

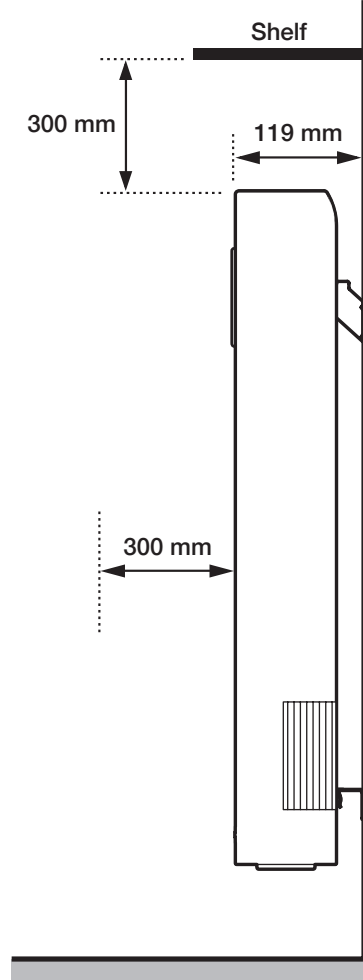
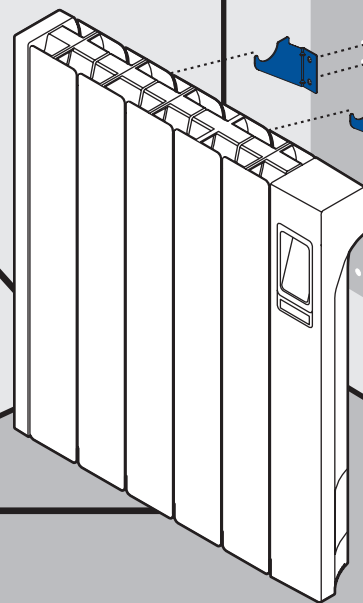
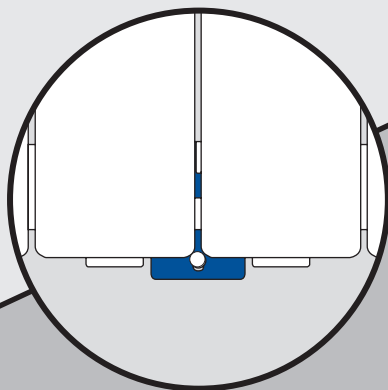
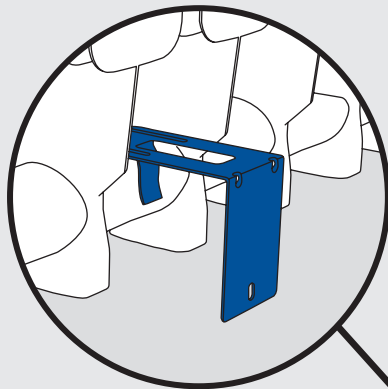

Fig. 3



*Please note correct product orientation.

Quick Start Guide

This guide is for quick reference only.
Please refer to the operating section for further information.

How Does the Heater Control Work?

The control allows you to choose when you want heat and at what temperature. When using a timer mode (see below), **Comfort On** will display on the home screen to tell you when the heater is maintaining the temperature displayed. **Comfort Off** will display when the heater is outside of a timed heating period. When **Manual**, **Eco** or **Frost** modes are being used the heater will always maintain the temperature shown on the home screen.

Set the Time

To set the date and time on the heater, press **Menu**, then press the **Enter** with **Time / Date** highlighted. Press \wedge or \vee until the correct value is shown, then press **Enter** to confirm and move on to the next value. Repeat until all details are correct, and **Set** displays, then press **Back**. The time is automatically adjusted in spring and autumn between **Greenwich Mean Time (GMT)** and **British Summer Time (BST)**.

Set the Temperature

The temperature shown on the display is the room temperature set point. This is the temperature that the heater will maintain during the heating periods. If the room temperature is above this temperature then the heater will not operate. The heater leaves the factory with this temperature set at 21°C which represents a typical, comfortable room temperature. If you require a different room temperature then press either \wedge or \vee until the display shows the temperature you require.

Timer Modes

Your Creda Aluminium Radiator comes pre-programmed with four timer modes. These modes define the periods when the heater will operate in **Comfort On** mode.

The four available modes are illustrated in the adjoining table.

Timer Mode	Description
Out All Day	6 hours heating per day in two periods
Home All Day	13 hours heating per day in one period
Holiday	Set the temperature and number of days for which you are on holiday
User timer	Customise times in four periods

Child Lock

If you need to lock the controls so that the settings cannot be changed then activate the **Child Lock**. To lock the controls press and hold both the **Back** button and **Enter** for three seconds. **Child Lock** will appear at the bottom of the screen. To unlock the control repeat the action by pressing both the **Back** button and **Enter** for three seconds.

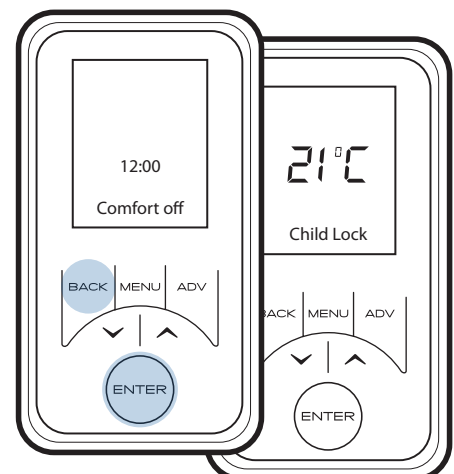

Which Timer Mode is Best for Me?

The heater leaves the factory set in **Out All Day** mode. If you are out during the day and only require heat in the mornings and evenings then this mode will suit your lifestyle and you won't need to alter anything. If you are in during the day then you should select the **Home All Day** mode which is a single heating period. The **User Timer** mode will give you four periods of heating split throughout the day. If you are away for an extended period then you can use the **Holiday** mode. This allows you to reduce the heating during the period that you are away, reverting to the previously selected mode on the day you return.

To choose a timer mode press **Menu** followed by **Enter** to select **Timer Mode**. Select the mode required by pressing \wedge or \vee and then **Enter**. For options **Out All Day**, **Home All Day** and **User Timer**, three choices are available **Select**, **Preview** and **Modify**.

Select - Choose this timer option
Preview - View the times currently set
Modify - Change the times currently set

Please refer to page 14 'Choosing and Setting a Mode' in these operating instructions for information on how to modify the programmed times.

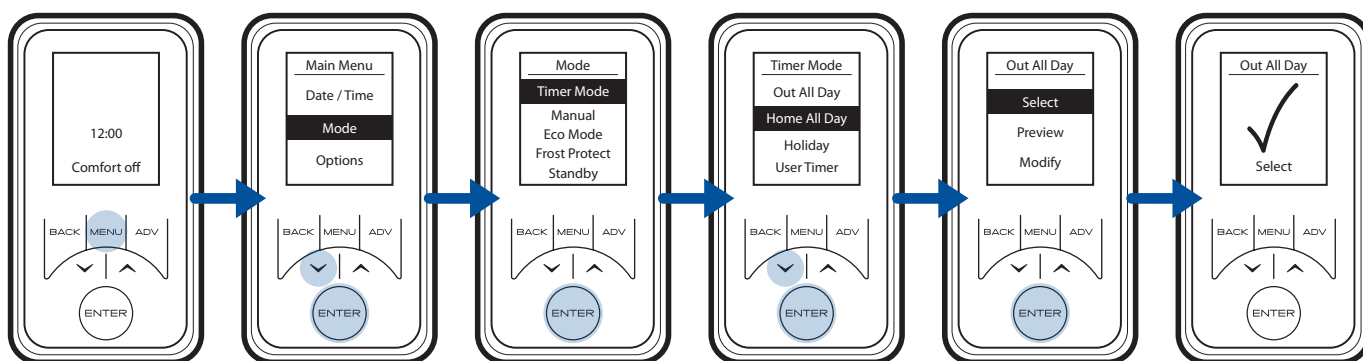

Advance

Sometimes you may be at home when you had not planned to be, or need to leave when you had planned to have the heating on. You can change the way you use your heating temporarily, this temporary change is achieved by using the **Advance** function.

When a timer has been selected, the **Advance** function allows you to begin the next period early. If the heater is in a **Comfort Off** period and you want heat - press the **Advance** button. If the heater is in **Comfort On** and you don't want heat, press the **Advance** button and it will go off until the beginning of the next **Comfort On** period.

Advance Boost

The **Advance** button is also used to enter the boost mode which provides temporary heating for one, two, three or four hours. Press the **Advance** button twice to begin a one hour boost. Continue pressing the **Advance** button to enter the longer boost periods.

Operation

WARNING - FAILURE TO FOLLOW THESE OPERATING INSTRUCTIONS MAY RESULT IN INJURY AND/OR DAMAGE.

The controls are located on the upper right hand side of the front face of the panel heater. The heater is fitted with an adjustable electronic controller consisting of a display screen and six touch buttons.

- ① Display Screen
- ② 'Menu' Button
- ③ 'Back' Button
- ④ 'Up and Down' Arrows
- ⑤ 'Enter' Button
- ⑥ Heating Status
- ⑦ 'Advance' Button

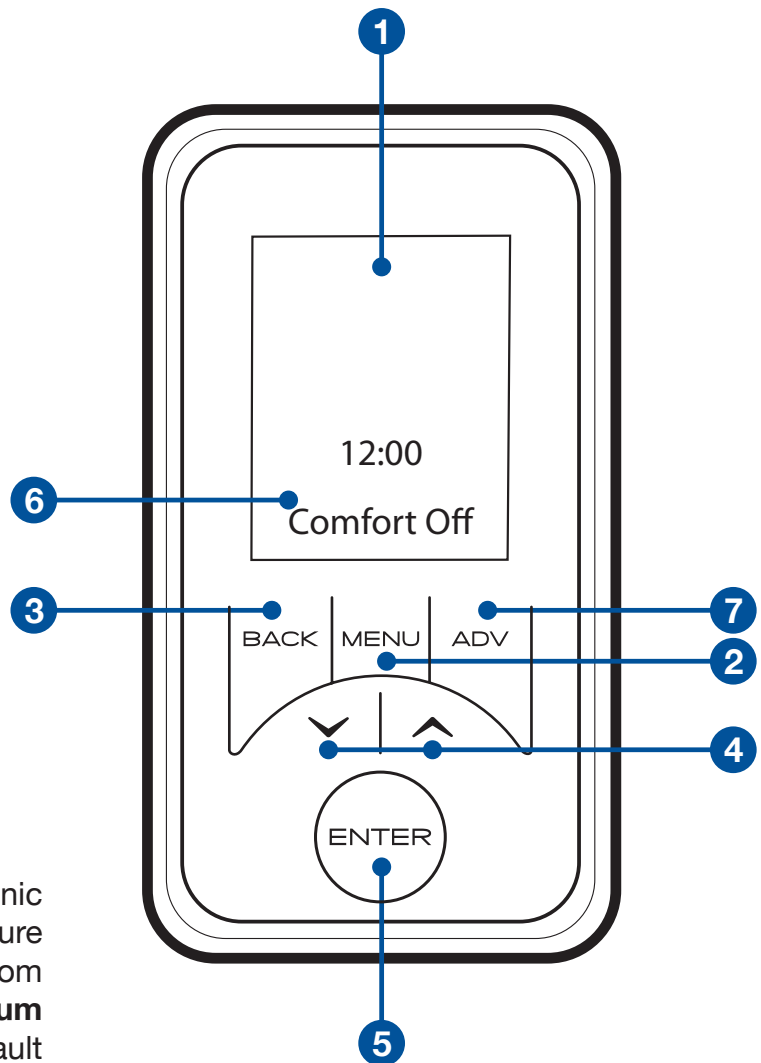

The heater is fitted with an electronic thermostat enabling the room temperature to be controlled.. The **minimum** room temperature is 7°C. The **maximum** temperature is set to 26°C by default however this can be increased to 32°C if required, see User information section on page 15.

A temperature of 21°C represents a **normal** room temperature.



NOTE:
Should the heater not operate, this may be due to the room temperature being higher than the thermostat setting.

Control Functions

The heater controls can be easily adjusted by using the six buttons on the User Interface.

- 1 The **Display Screen** shows the options available at each stage of adjustment.
- 2 **Menu** - displays the main options list;
 - **Date/Time** - Set the date and time.
 - **Mode** - Set the mode of operation.
 - **Options** - Temperature units, daylight savings time, lock settings and service information.
- 3 **Back** returns to the previous programming stage.
- 4 The ^ and v buttons are used to navigate through the menus and alter setting values. The ^ and v buttons are also used to adjust the required room temperature on the main screen. The screen colour changes based on the temperature selected, showing deep blue through to bright red.

7C -16 C = Blue Screen
17- 19C = Green Screen
20- 21C = White Screen
22C + = Red Screen
- 5 **Enter** is used within the menu options to confirm settings. On the main screen pressing **Enter** will display the enabled features.
- 6 **Heating Status** is the timed periods during which the heater is providing heat are defined as **Comfort On** (this is displayed at the bottom of the screen). While constant heat modes are active, the mode of operation is displayed at the bottom of the screen e.g. **Manual**.
- 7 The **Advance** button overrides the heating settings and changes the operational state of the heater. If a timer mode is selected, pressing **Advance** will cause the heater to remain on until the next **Comfort Off** period is due, or off until the next **Comfort On** period is due.

If the heater is in a constant mode of operation, **Advance** can be used to switch the heater on and off.

Advance is also used to enter **Boost** mode. **Boost** mode delivers heat for between one and four hours.

Main Screen

After 30 seconds the heater will default back to the **Main Screen**. Here the chosen temperature is displayed along with the mode of operation. Any use of the **Advance** function will be displayed here, and pressing **Enter** will show the functions which are enabled.

When left inactive for a long period of time this display will 'sleep' and the text will disappear. Press any button for its return.

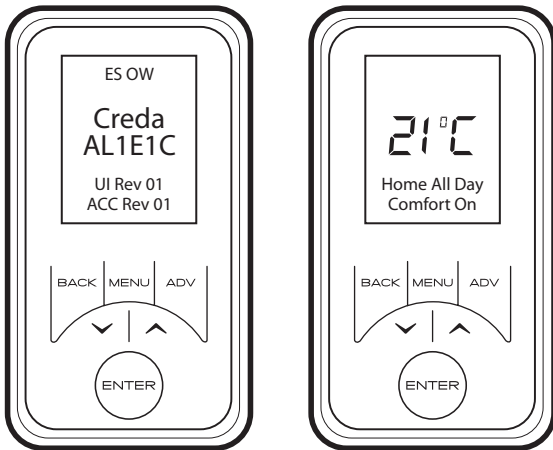

NOTE:

The display screen will return to the main screen after a period of 30 seconds of inactivity.



NOTE:

Pressing enter will show the functions which are enabled, e.g. ES and OW above. Ref: page 17.

Setting the Date and Time

The heater incorporates a real time clock with calendar function. The time clock has a battery backup that will keep the clock running in the event of a mains power outage.

To adjust the time or date follow the steps below.

Press the **Menu** button. Select **Date/Time** by pressing the **Enter** button. Press \wedge and \vee to select the correct day of the month and press **Enter** to select.

Repeat this operation, until the date and time has been set, ensuring to press **Enter** to select. Press **Back** button to return to the **Main Screen** once **Set** has been displayed.

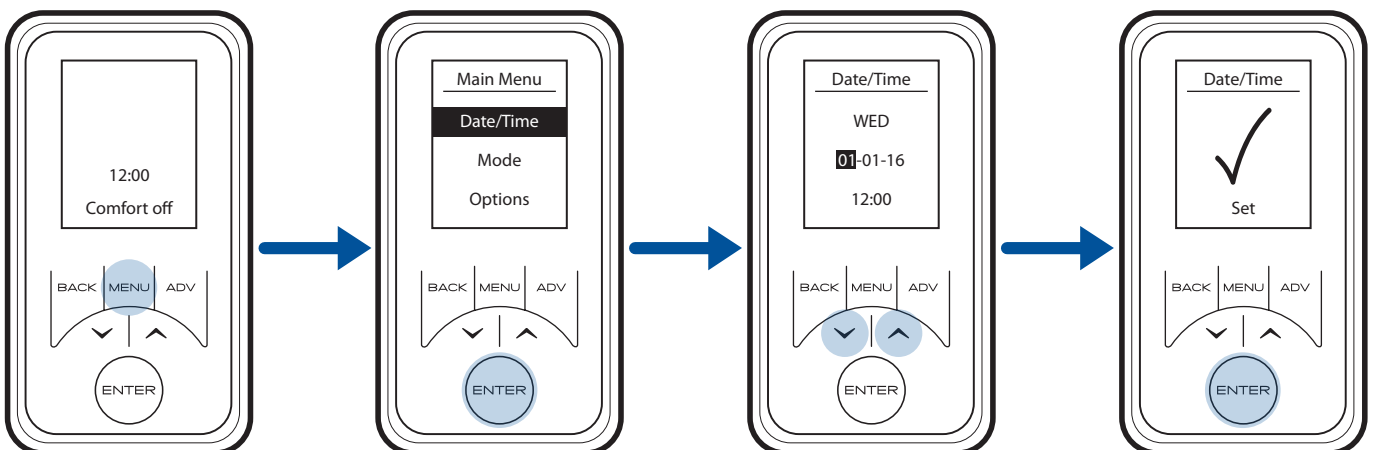

Modes of Operation

The heater comes pre-programmed with a set of heating profiles. There are four options available - three pre-programmed and one user adjustable timer;

1. **Out All Day** (pre-programmed) - has the following preset times Monday to Sunday, which can be altered if desired 07.00 until 08.30 17.30 until 22.00
2. **Home All Day** (pre-programmed) - has the following preset times Monday to Sunday, which can be altered if desired; 08.00 until 21.00
3. **Holiday** (pre-programmed for 7 days at 10°C) - set the number of days required (from 1 to 300) and the temperature required. 7°C is advised if you just want to protect the property from frost while you are away.
4. **User Timer** - provides greatest flexibility to the user. Four time slots are available throughout the day and these can be customised for each day of the week.

The heater can also maintain a constant room temperature using the following modes;

1. **Manual** mode heats the room to a comfortable temperature of 21°C.
2. **Eco Mode** maintains a room temperature of 18°C. By reducing the room temperature slightly, significant energy savings can be achieved. The green display colour indicates that selected temperature provides a comfortable room temperature while reducing energy consumption.
3. **Frost Protect** mode maintains a room temperature of 7°C. This mode should be used to provide protection against frost as indicated by the blue display.

Select **Standby** to switch the heater into standby mode, heating will not be provided. Press any of the buttons to resume operation in the previously selected mode.



NOTE:

In all modes, ^ and v can be used to adjust the required room temperature. In timer modes, this change is temporary and the heater will set the room temperature based on the saved heating profiles.

Choosing and Setting a Mode

Timer Modes

To choose a timer mode press **Menu** and then \downarrow to select **Mode**. Then press **Enter**. Then select **Timer Mode**, again using the **Enter** button.

Select the mode required, by pressing the \wedge or \vee followed by **Enter**.

For options **Out All Day**, **Home All Day** and **User Timer**, three choices are available - **Select**, **Preview** and **Modify**.

- **Select** - choose this timer option.
- **Preview** - view the times currently set.
- **Modify** - change the times currently set.

When **Modify** is chosen, select and change each option using the \wedge , \vee and **Enter** buttons. At the end of each period, select **Next** to move to the following period. When a day is complete select **Save** to update it.

Once the first day has been set up it is possible to copy these settings to successive days or all days by either choosing **Copy Next** or **Copy All**.

If preferred each day can be modified individually and saved. It is also possible to **Clear** each day or **Clear All** days. Options are;

- **Save** - save times for one day.
- **Copy Next** - copy times to following day.
- **Copy All** - copy times to all seven days.
- **Clear** - zero all times that day.
- **Clear All** - zero times for all seven days.



NOTE:

Once modified a programme must be selected if you want to begin using it.

To select a mode, choose **Select** and press **Enter**.

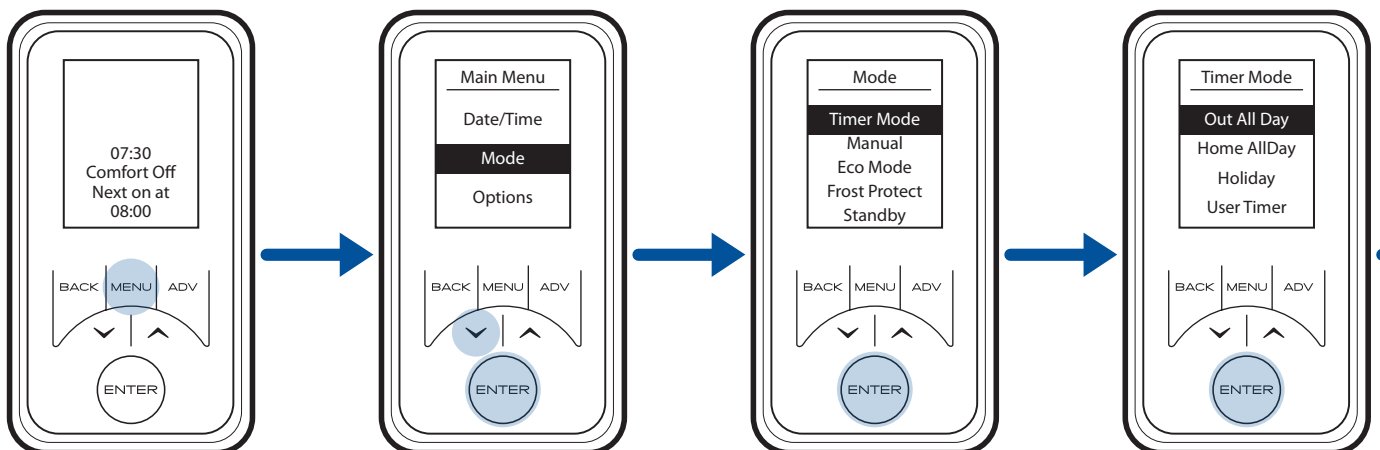

If anticipatory control is disabled, the heater will not operate until the beginning of the heating period. This should be taken into consideration when setting the heating periods.

In **Holiday** mode the number of days that the room will be unoccupied can be adjusted together with the required room temperature.

Press \wedge and \vee to choose a holiday period between 1 and 300 days, then press the **Enter** button.

Press \wedge and \vee to choose a temperature to be maintained during this period and press the **Enter** button. At the end of the holiday mode the heater will automatically revert back to the previously selected programme.

Constant Heat Modes

To choose a constant heat mode press **Menu** and \vee to select **Mode** and press **Enter**. Then select the required mode, again using the **Enter** button.



NOTE: If the anticipatory control is enabled the heater will maintain the room at the required temperature for the duration of the heating period. To achieve this, the heater will begin heating the room before the start of the heating period to ensure the room is at the required temperature when the period starts.

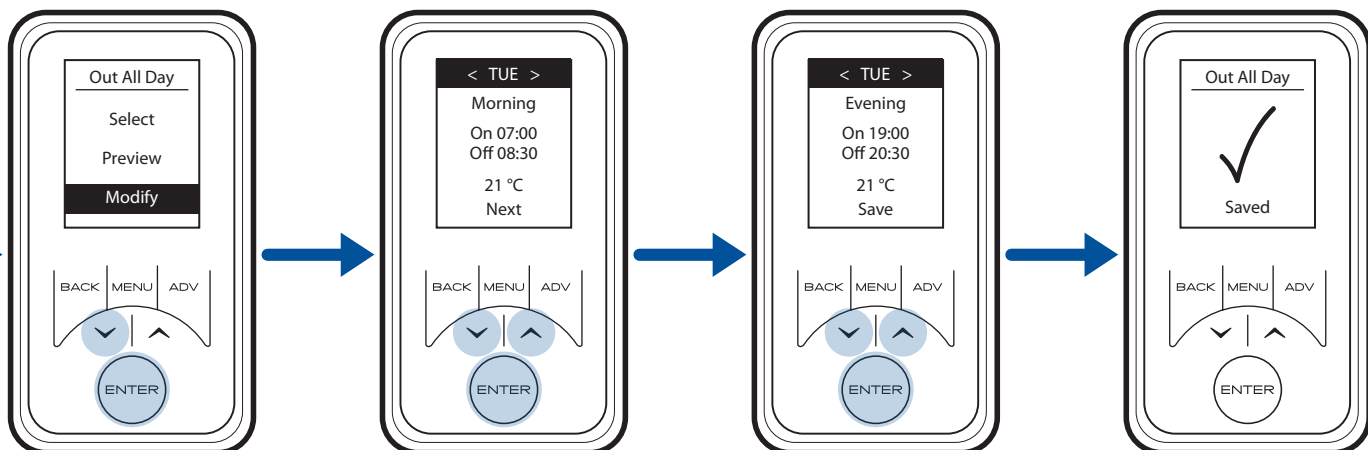

Advance

The **Advance** function allows the heating profile of the heater to be changed temporarily. When a timer has been selected, the **Advance** function is used to begin the next **Comfort On** mode early. If the heater is in **Comfort Off** mode and heat is required, press the **Advance** button.

If the heater is in **Comfort On** and heat is not required, press the **Advance** button and the heater will turn off until the beginning of the next **Comfort On** period. If the heater is in **Manual, Eco Mode** or **Frost Protect** and pressing the **Advance** button will switch off the heater. The heater will remain off until the **Advance** button is pressed again.



Boost

The **Advance** button is also used to enter the **Boost** mode which provides temporary heating for one, two, three or four hours. Press the **Advance** button twice to begin a one hour boost. Continue pressing the **Advance** button to set longer boost period.



Options

The **Options** menu allows the settings to be modified to suit the user's preferences. These are;

DST Rule - Select your daylight saving setting. The heater clock will automatically adjust for daylight saving (British Summer Time as it is often referred to). If no adjustment is required then select none.

Auto Lock - Enable or disable the auto lock feature. This feature locks the interface if left inactive for longer than one minute. To unlock the heater, press and hold **Back** and **Enter** for two seconds.

Sound - Audio feedback can be enabled or disabled.

Service Info - Service information is displayed.

Temp Units - Choose whether your unit displays degrees centigrade or Fahrenheit.

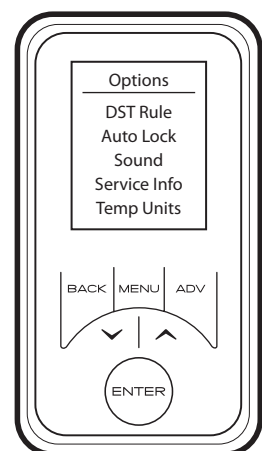

Child Lock

To lock the controls press **Back** and **Enter** for three seconds. **Child Lock** will appear at the bottom of the screen. To unlock the control repeat the action of pressing **Back** and **Enter** for three seconds.



NOTE:
The controls cannot be adjusted when child lock is active.

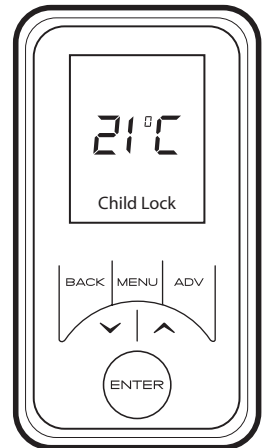

User Information

User Information

Press and hold **Enter** for five seconds to display the **User Information** menu;

SP Range allows adjustment of the maximum temperature range.

Open Window detection (OW), when enabled, the heater will reduce the target room temperature to limit the energy waste when an open window is detected. Enabled as default.

Bluetooth - allows the Bluetooth pairing function to be enable or disable.

EcoStart (ES) - to achieve the desired temperature at the onset of the timed **Comfort On** period the appliance anticipates when it needs to start heating prior to the onset of the timed on period. E.g. room is 16°C, with 21°C at 7am set on the timer. With ES on the control will start to heat the room before 7am, reaching 21°C at this time. With ES off the heater will start to heat the room at 7am and will reach 21°C after this time.

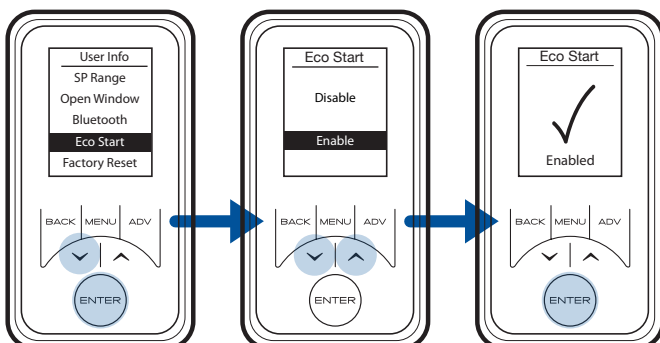
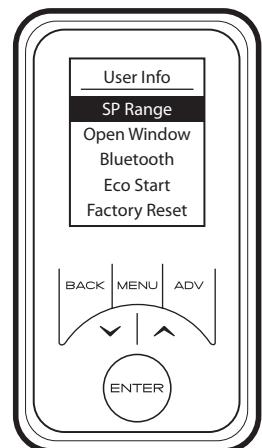

NOTE:
Eco Start is enabled by default.

Factory Reset returns all settings to the factory presets.

Runback Lock Mode

Introduction

This appliance has a built in runback lock mode, when this mode is activated all functionality of the appliance is locked and the user will only have the ability to activate a runback timer functionality. It is possible to limit the maximum operating temperature and runback duration in the runback lock mode. This mode also features a setback function where a nonadjustable setback temperature can be set

Operation in Runback mode

When runback mode is active the appliance settings are locked, it is only possible for the user to activate predetermined runback periods. During these periods the appliance will energise to control the room to a desired temperature. During a runback period the set point can be adjusted by the user however, it is possible to assign a maximum set point limit during the runback mode setup. Once the runback period has elapsed the appliance will switch into Comfort off mode or into setback mode if enabled.

To activate a runback period the user must press the **ADV** button. There will be four runback periods available to chose from which are accessible through sequential presses of the **ADV** button. A subsequent press of the **ADV** button will return the appliance to Comfort off mode or setback mode

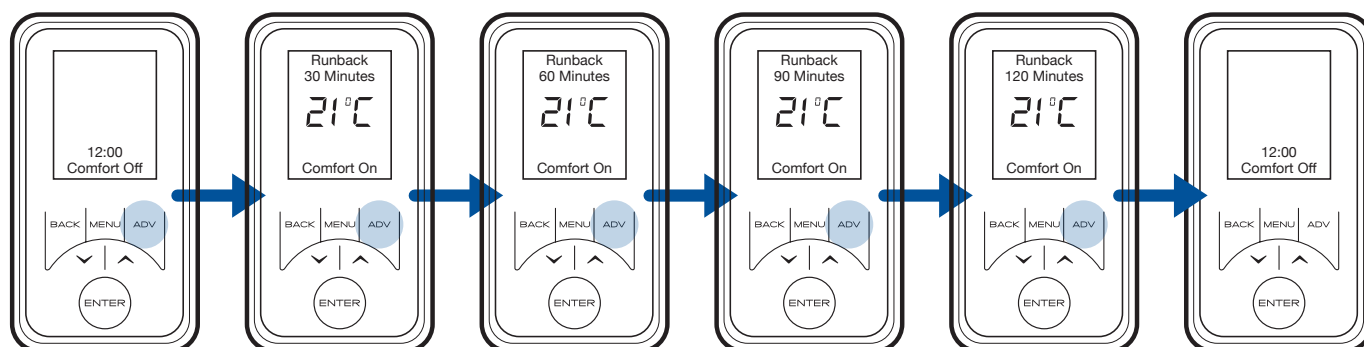

Runback Lock Mode

In order to enter the runback lock mode, Back, Menu & Enter must be pressed simultaneously and held for 10 seconds. The user will then be prompted to enter the runback lock PIN.



NOTE: The default password is 0000, the password be changed from within the runback lock mode menu.

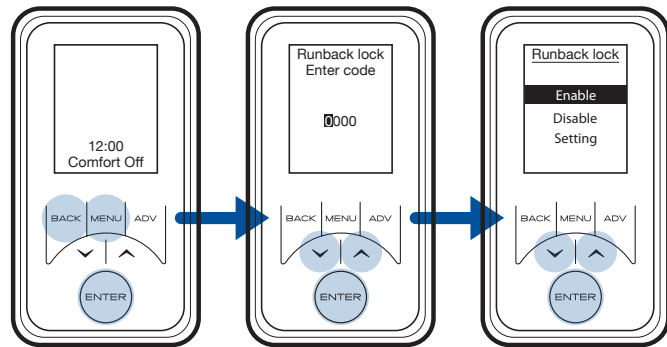

Enabling runback timer mode

From the main Runback lock menu select Enable and confirm selection using the **Enter** key. Runback mode will be enabled, normal functionality of the appliance will be disabled allowing only the Runback mode functionality.

Disabling runback timer mode

From the main Runback lock menu select Disable and confirm selection using the **Enter** key. Runback mode will be disabled and full appliance functionality will be enabled.

Runback Mode Settings

Changing the Password

It is possible to set a user defined runback lock PIN code. Once changed, the PIN code will be required to access the Runback timer mode menus.

To change the PIN code select 'Settings' from the main Runback lock menu and then select Change code. To complete the change follow the on screen instructions, it will be necessary to input the current PIN and then the new PIN code.

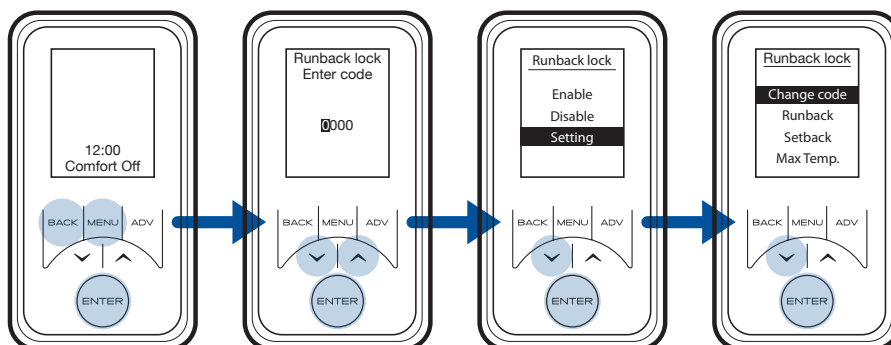

Runback Duration

During setup it is possible to select from a number of preset runback periods. This is achieved by selecting the maximum runback time. The maximum runback time is subdivided into four periods to deliver options to the user, the maximum time options and corresponding runback periods are shown in the table below.

To set the Maximum time period select 'Runback' from the runback lock settings menu. The arrow keys can be used to toggle the selection, **Enter** then confirms the selection. Ensure to select a Max duration with runback periods suitable to the application.

Max Duration	Period			
	1	2	3	4
30	15	20	25	30
60	15	30	45	60
90	15	30	60	90
120	30	60	90	120
240	60	120	180	240
360	90	180	270	360
480	120	240	360	480

Setback Mode

It is possible activate a setback mode, this ensures that when the runback lock is enabled and the appliance is not in a runback period then the appliance does not switch off, it enters set back mode. The setback temperature can be set during the runback lock setup.

The setback mode can be enabled or disabled from within the Runback lock settings menu. It is also possible to alter the setback temperature from this menu.



NOTE: The set back temperature can not be adjusted when the runback lock mode is enabled.

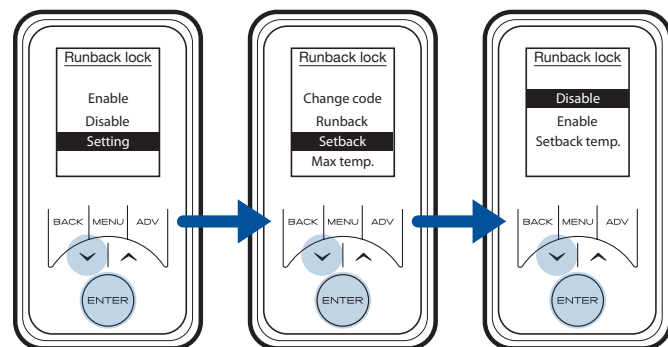

Runback mode, Maximum Temperature

A maximum temperature limit for the room during runback can be applied. This will restrict the users ability to increase the room temperature beyond a set value during a runback period. The maximum temperature can be set by selecting 'Max Temp.' in the Runback lock settings menu. The temperature can be adjusted using the arrow keys and then confirmed using the **Enter** Key.

Energy Saving Tips

The energy we use to heat, light and power our homes contributes over a quarter of the UK's carbon emissions, the principle contributor to climate change. Around half the energy used in the home is for heating and hot water, so using your heating system efficiently will not only help the environment, but also save you money.

Energy efficiency tips for heating and hot water

- 1. Don't set the temperature to high...**
By reducing the thermostat setting by just 1°C can reduce your energy use by as much as 10%. And if you're going away during the winter, leave the thermostat on the frost protection setting to provide protection from freezing at a minimum cost.
- 2. Use it where you need it...**
Set the appropriate temperature on your heaters for the room they are in; for example, leave the thermostat on a heater in a spare bedroom on a lower setting.
- 3. Use it when you need it...**
Use heaters fitted with timers or linked to central controllers to turn the heating on only when you need it and automatically switch it off when you don't.
- 4. Curtains**
Close your curtains at dusk to stop heat escaping through the windows.
- 5. Windows**
Nearly 25% of heat loss can occur through poorly insulated frames and single glazing. If you can't afford to double glaze all your windows, go for the rooms you heat most.
- 6. Treat your hot water tank...**
Give it a jacket An insulating jacket for hot water tanks costs only a few pounds and pays for itself within months. Fit one that's at least 75mm (3") thick and you could save £10-15 a year.
- 7. Water**
Use a shower if you have one to save time, money and water. Don't set the thermostat too high on your water heater - 60°C/ 140°F is usually adequate for bathing and washing. Put the plug in when running hot water in your sink - leaving hot taps running is both wasteful and expensive. Ensuring dripping taps are repaired quickly. In just one day, you could waste enough water to fill a bath.

Other Energy Saving Tips for Around the Home

- 1. Lights**
Turn off lights whenever you leave a room for more than ten minutes. Use low-energy bulbs wherever you can as they use less than a quarter of the electricity used by ordinary light bulbs and last ten times longer!
- 2. Cooking**
Use the right size pan for food and cooker hob. Keep saucepan lids on - this enables you turn down the heat. Boil water for cooking in a kettle first.

Energy Related Product Directive

Model Identifier(s):		CAR 033	CAR 050	CAR 075	CAR 100	CAR 150	CAR 200	
Heat output								
Nominal heat output	P _{nom}	0.33	0.50	0.75	1.00	1.50	2.00	kW
Minimum heat output (indicative)	P _{min}	N.A.	N.A.	N.A.	N.A.	N.A.	N.A.	kW
Maximum continuous heat output	P _{max,c}	0.33	0.50	0.75	1.00	1.50	2.00	kW
Auxiliary electricity Consumption								
At nominal heat output	e _{lmax}	0.00	0.00	0.00	0.00	0.00	0.00	kW
At minimum heat output	e _{lmin}	0.00	0.00	0.00	0.00	0.00	0.00	kW
In standby mode	e _{lSB}	0.0005	0.0005	0.0005	0.0005	0.0005	0.0005	kW
Type of heat output/ room temperature control								
With electronic room temperature control								Yes
Electronic room temperature control plus week timer								Yes
With open window detection								Yes
With adaptive start control								Yes

Contact details

Creda Heating, Milbrook House, Grange Drive, Hedge End, Southampton, SO30 2DF

This product complies with Lot20 of the Energy Efficiency Directive (2015/1188).

Important

During the initial operation, some odour may be noticed due to the newness of materials used in manufacture. This is normal and will disappear after a short period or use. It is however advisable to keep the room well ventilated.

Cleaning

WARNING - ALWAYS DISCONNECT FROM THE POWER SUPPLY BEFORE CLEANING THE HEATER. Before commencing cleaning, unplug the heater and allow it to cool. Disconnect the electricity supply to the appliance. The outside can be cleaned by wiping it over with a soft damp cloth and then dried. Do not use abrasive cleaning powders or furniture polish, as this can damage the surface finish. To release the heater from the wall for cleaning or redecoration, remove the 2 screws from the bottom retaining brackets. You will then be able to lift the heater off the top brackets (See **Fig. 3**).

CAUTION - We recommend that you arrange for this heater to be checked regularly for safety by a suitably qualified or trained electrician.

Your Guarantee



To view the full guarantee terms and conditions scan this QR code using your smartphone or go to <https://www.gdhv.co.uk/guarantee-terms-and-conditions>.

Your Product is manufactured by Glen Dimplex UK operating as Glen Dimplex Heating & Ventilation. GDHV designs and manufactures products to ensure they deliver reliable service for normal use in domestic dwellings and, where specified by us, in light commercial premises.

GDHV products are individually tested before leaving the factory, Your product comes with a 2 year parts and labour guarantee for repair or replacement of faulty goods and/or partial refund in the event that a repair or replacement is not available.

Your guarantee is provided by Glen Dimplex UK Ltd operating as Glen Dimplex Heating & Ventilation Ltd, Millbrook House, Grange Drive, Southampton SO30 2DF. Terms and conditions apply.

The GDHV guarantee does not in any way diminish or affect your statutory consumer rights in connection with your product.

If you experience a problem with your product during or after the guarantee period, visit our online help centre: <https://www.credaheating.co.uk/gdhv-help-centre>

If you cannot solve your issue online, contact the customer care team on 0344 879 3588

Please note that when you contact us you will need to provide the model and serial number of your product and a description of the fault which has occurred.

Why register your products with us?



Faster Customer Service

Once you have registered your product, our customer service team will be able to quickly access your details when you contact us, allowing them to help you sooner.



Guarantee Management

Upon registration, you will receive a confirmation email including a summary of your product guarantee, a copy of our terms and conditions and a copy of your proof of purchase (optional).



Product Recall Notification

If your product is registered you will automatically be contacted with applicable safety notifications, or in the unlikely event of a product recall.

Please register your product with us within 28 days of date of purchase to enable us to provide efficient customer service if you need to contact us, to contact you in the event of a product or safety update, to extend your guarantee where applicable, and, if you choose, to send you additional information about our products and services.

Register your product at <https://www.gdhv.co.uk/register>, or if you do not have access to the internet, call us on 0344 879 3588.

On registering you will automatically receive a copy of the terms and conditions of your guarantee, which can also be downloaded at any time from <https://www.gdhv.co.uk/guarantee-terms-and-conditions>. If you do not have access to the internet, call us on 0344 879 3588 and we will send them to you by post.

Recycling



For electrical products sold within the European Community. At the end of the electrical products useful life it should not be disposed of with household waste. Please recycle where facilities exist. Check with a Local Authority or retailer for recycling advice in your country.

Creda

Customer Helpline: 0844 879 3588
Email: presales@credaheating.co.uk
Email: aftersales@credaheating.co.uk

www.credaheating.co.uk

Millbrook House, Grange Drive, Hedge End, Southampton, SO30 2DF
For ROI please email serviceshared@dimpco.ie or call +353(0)1 842 8222



© Glen Dimplex UK Limited. All rights reserved. Material contained in this publication may not be reproduced in whole or in part, without prior permission in writing of Glen Dimplex