



Please keep me in a safe place for future use.

5116231/10

INSTALLATION AND OWNER GUIDE

Model 939

OPEN DECORATIVE GAS FIRE

(GC No. 32-032-54)



We trust that this guide gives sufficient details to enable this appliance to be installed, operated and maintained satisfactorily. However, if further information is required, our

Technical Helpline will be pleased to help.

Telephone **0344 879 35 88** (National call rates apply in the United Kingdom).

In the Republic of Ireland
Telephone **01 842 8222**.



INSTALLER: Please leave this guide with the owner

THIS APPLIANCE IS FOR USE WITH NATURAL GAS (G20).

**WHEN CONVERTED USING CONVERSION KIT NO. 0595211 THIS APPLIANCE
IS FOR USE WITH PROPANE GAS (G31).**

**THIS APPLIANCE IS SUITABLE ONLY FOR INSTALLATION IN THE UNITED
KINGDOM (GB) AND THE REPUBLIC OF IRELAND (IE).**

Glen Dimplex UK Ltd.

All rights reserved. No part of this publication may be reproduced in any material form (including photocopying), stored in any medium by electronic means (including in any retrieval system or database) or transmitted, in any form or by any means, whether electronic, mechanical, recording or otherwise, without the prior written permission of the copyright owner.

Applications for the copyright owner's permission to reproduce any part of this publication should be made, giving details of the proposed use, to the following address: The Company Secretary, Glen Dimplex UK Ltd, Millbrook House, Hedge End, Southampton, SO30 2DF.

Warning: Any person who does any unauthorised act in relation to a copyright work may be liable to criminal prosecution and civil claims for damages.

Because our policy is one of constant development and improvement, details may vary slightly from those given in this publication

Safety First.

This fire is UKCA and CE Approved and designed to meet the appropriate British Standards and Safety Marks.



Quality and Excellence.

This fire has been manufactured to the highest standards of quality and excellence.

The Highest Standards

GDG is a member of the Benchmark scheme and HHIC (Heating and Hot water Industry Council) that work to ensure high standards of safety, quality and performance.



Careful Installation

This gas fire must be installed by a competent GAS SAFE REGISTER operative in accordance with this installer guide.



INSTALLER GUIDE

FOR OWNER GUIDE SEE PAGES 29 TO 43

INSTALLER GUIDE

CONTENTS

<u>Section</u>	<u>Heading</u>	<u>Page</u>
	INSTALLER GUIDE	4 - 28
	OWNER GUIDE	29 - 43
1.	SAFETY AND UNPACKING	7
2.	LIST OF ACCESSORIES & BENCHMARKING SCHEME	8
3.	APPLIANCE DATA AND EFFICIENCY	9
	3.1 General information.	9
	3.2 Efficiency.	9
4.	GENERAL INSTALLATION REQUIREMENTS	10
	4.1 Regulations, Standards and Law.	10
	4.2 Ventilation requirements.	12
	4.3 The Atmosphere sensing device (ASD).	12
	4.4 Fireguard requirements.	12
	4.5 Room considerations.	12
	4.6 Chimney preparation.	12
	4.7 Fireplace preparation.	13
	4.8 The hearth.	13
	4.9 Fireplace clearances.	14
	4.10 Installation options.	15
	4.11 Propane appliances.	16
5.	UNPACKING	18
6.	INSTALLATION OF APPLIANCE	18
	6.1 Fireplace size.	18
	6.2 Fireplace flue pull.	18
	6.3 Installation of the burner unit	19
7.	BURNER AND SUPPLY PIPE INSTALLATION	21
	7.1 Preliminary burner checks.	21
	7.1.1 Lighting the fire	21
	7.1.2 Operating the burner.	21
	7.1.3 Checking the inlet pressure.	22
8.	FITTING THE FIREFRONT	22
9.	FITTING THE CERAMIC FUEL EFFECT	24

Continued on next page

INSTALLER GUIDE

CONTENTS (Continued)

<u>Section</u>	<u>Heading</u>	<u>Page</u>
10.	FULL OPERATING CHECKS	24
10.1	Spillage check.	24
10.2	Flame Supervision & Spillage Monitoring System.	25
10.3	Final Review.	25
11.	SERVICING & PARTS REPLACEMENT	26
11.1	Checking the aeration setting of the burner.	26
11.2	To remove the complete burner unit.	26
11.3	To remove the pilot unit.	27
11.4	To remove the gas valve.	27
11.5	To remove the piezo generator.	28
11.6	To grease the control tap.	28
11.7	To replace the burner.	28
11.8	To remove the main burner injector.	28

INSTALLER GUIDE

1. SAFETY AND UNPACKING

Installer

Before continuing any further with the installation of this appliance please read the following guide to manual handling:

- The lifting weight of this appliance (DGF burner) is 2 kg. One person should be sufficient to lift the fire. If for any reason this weight is considered too heavy then obtain assistance.
 - When lifting always keep your back straight. Bend your legs and not your back.
 - Avoid twisting at the waist. It is better to reposition your feet.
 - Avoid upper body/top heavy bending. Do not lean forward or sideways whilst handling the fire.
 - Always grip with the palm of the hand. Do not use the tips of fingers for support.
 - Always keep the fire as close to the body as possible. This will minimise the cantilever action.
 - Use gloves to provide additional grip.
 - Always use assistance if required.
-

This product uses fuel effect pieces containing Refractory Ceramic Fibres (RCF), which are man-made vitreous silicate fibres. Excessive exposure to these materials may cause irritation to eyes, skin and respiratory tract. Consequently, it is important to take care when handling these articles to ensure that the release of dust is kept to a minimum. To ensure that the release of fibres from these RCF articles is kept to a minimum, during installation and servicing we recommend that you use a HEPA filtered vacuum to remove any dust and soot accumulated in and around the fire before and after working on the fire. When replacing these articles we recommend that the replaced items are not broken up, but are sealed within a heavy duty polythene bag, clearly labelled as RCF waste. RCF waste is classed as a stable, non-reactive hazardous waste and may be disposed at a landfill licensed to accept such waste. Protective clothing is not required when handling these articles, but we recommend you follow the normal hygiene rules of not smoking, eating or drinking in the work area and always wash your hands before eating or drinking.

This appliance does not contain any component manufactured from asbestos or asbestos related products.

INSTALLER GUIDE

2. LIST OF ACCESSORIES & BENCHMARK SCHEME

<u>Description</u>	<u>Part Number</u>
<u>All Models</u>	
LPG Conversion kit	0595211
<u>'Quattro' / 'Anthem', 'Majestic' and Models not supplied with a firefront</u>	
Replacement Chair brick	0552311
Replacement Chair brick Trims	
- Flat Brass effect	0552321
- Flat Satin Chrome effect	0552331
- Flat Black	0552341
<u>'Azure' Model</u>	
Replacement Chair brick	0552301



The Benchmark Scheme

Glen Dimplex UK is a licensed member of the Benchmark Scheme which aims to improve the standards of installation and commissioning of domestic heating and hot water systems in the UK and to encourage regular servicing to optimise safety, efficiency and performance. Benchmark is managed and promoted by the Heating and Hotwater Industry Council. It places responsibilities on both manufacturers and installers. The purpose is to ensure that customers are provided with the correct equipment for their needs, that it is installed, commissioned and serviced in accordance with the manufacturer's instructions by competent persons and that it meets the requirements of the appropriate Building Regulations.

The Benchmark Checklist (on the inside back pages of this guide) can be used to demonstrate compliance with Building Regulations and should be provided to the customer for future reference.

Installers are required to carry out installation, commissioning and servicing work in accordance with the Benchmark Code of Practice which is available from the Heating and Hotwater Industry Council who manage and promote the Scheme.

Visit www.centralheating.co.uk for more information.

At the time of commissioning, complete all relevant sections of the Benchmark

INSTALLER GUIDE

Checklist located on the inside back pages of this document.

3. APPLIANCE DATA AND EFFICIENCY

Gas	Natural (G20)	Propane (G31) *
Inlet Pressure	20 mbar	37 mbar
Input - Max. (Gross)	6.85 kW (23,400 Btu/h)	6.7 kW (22,860 Btu/h)
Input - Min. (Gross)	2.3 kW (7,850 Btu/h)	4.0 kW (13,650 Btu/h)
Burner Test Pressure (Cold)	20.0 ± 1.0mbar (8.0 ± 0.4in w.g.)	37.0 ± 1.0mbar (14.85 ± 0.4in w.g.)
Gas Connection	8mm pipe	8mm pipe
Burner Injector	Cat 82 - 074	Size 132
Pilot & Atmosphere Sensing Device	Copreci Ref. O.D.S 21500/166	Copreci Ref. O.D.S 21500/166 Fitted with RBM 180 -02 injector
Ignition	Integral Piezo Spark	Integral Piezo Spark
Aeration	Factory set	Non-adjustable

3.1 General information.

*When converted using kit 0595211

3.2 Efficiency.

There are no specific thermal efficiency requirements appropriate to this type of appliance as they are intended for decorative purposes only. For the purposes of SAP the efficiency is classed as 20% for use in the Space Heating Requirements calculation, see Table 4a of SAP.

INSTALLER GUIDE

4. GENERAL INSTALLATION REQUIREMENTS

4.1 Regulations, Standards and Law.

The installation must be in accordance with these instructions.

For the user's protection, in the United Kingdom it is the law that all gas appliances are installed by competent persons in accordance with the current edition of the Gas Safety (Installation and Use) Regulations. Failure to install the appliance correctly could lead to prosecution. GAS SAFE REGISTER and CORGI require their members to work to recognised standards. In the United Kingdom the installation must also be in accordance with:

All the relevant parts of local regulations.

All relevant codes of practice.

The relevant parts of the current editions of the following British Standards:-

BS 1251 -	Fireplace components
BS 5440 Part 1 -	Installation of flues.
BS 5440 Part 2 -	Installation and maintenance of flues and ventilation for gas appliances of rated input not exceeding 70 kW net (1st, 2nd and 3rd family gases).
BS 5871 Part 2 -	Installation - Inset LFE gas fires
BS 6461 Part 1 -	Masonry chimney & flues - Installation
BS 6891 -	Gas pipework installation

- In England and Wales, the current edition of the Building Regulations issued by the Department of the Environment and the Welsh Office.
- In Scotland, the current edition of the Building Standards (Scotland) Regulations issued by the Scottish Executive.
- In Northern Ireland, the current edition of the Building regulations (Northern Ireland) issued by the Department of the Environment for Northern Ireland.
- In the republic of Ireland the installation must be carried out by a competent person and also conform to the relevant parts of:

The current editions of:-

IS 813 "Domestic Gas Installations"

ICP3

IS327

All relevant national and local rules in force.

Where no specific instructions are given, reference should be made to the relevant British Standard Code of Practice.

INSTALLER GUIDE

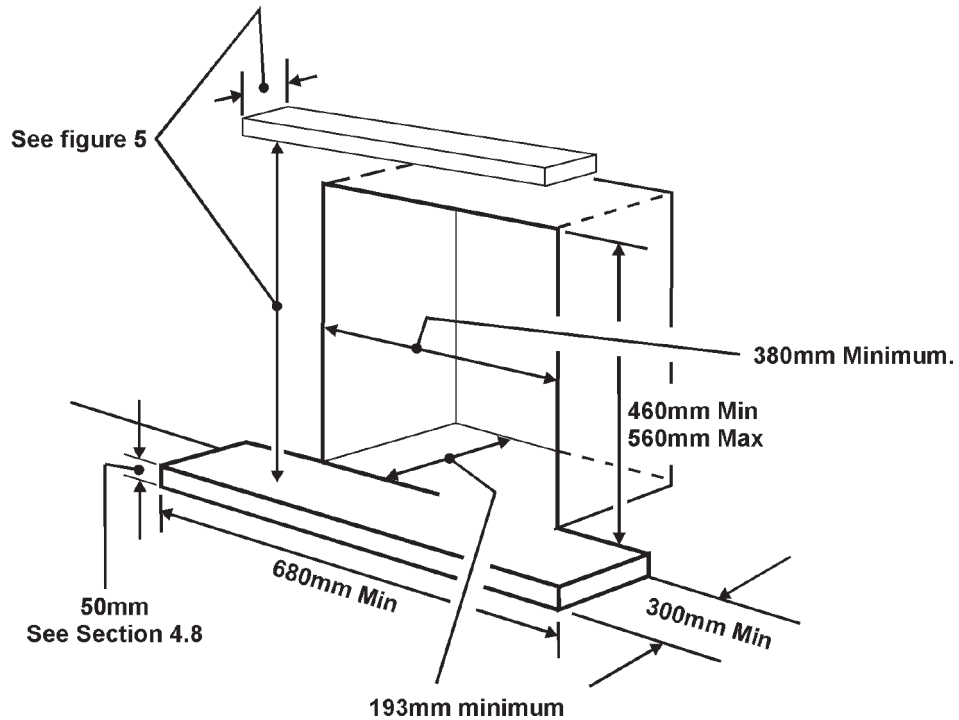
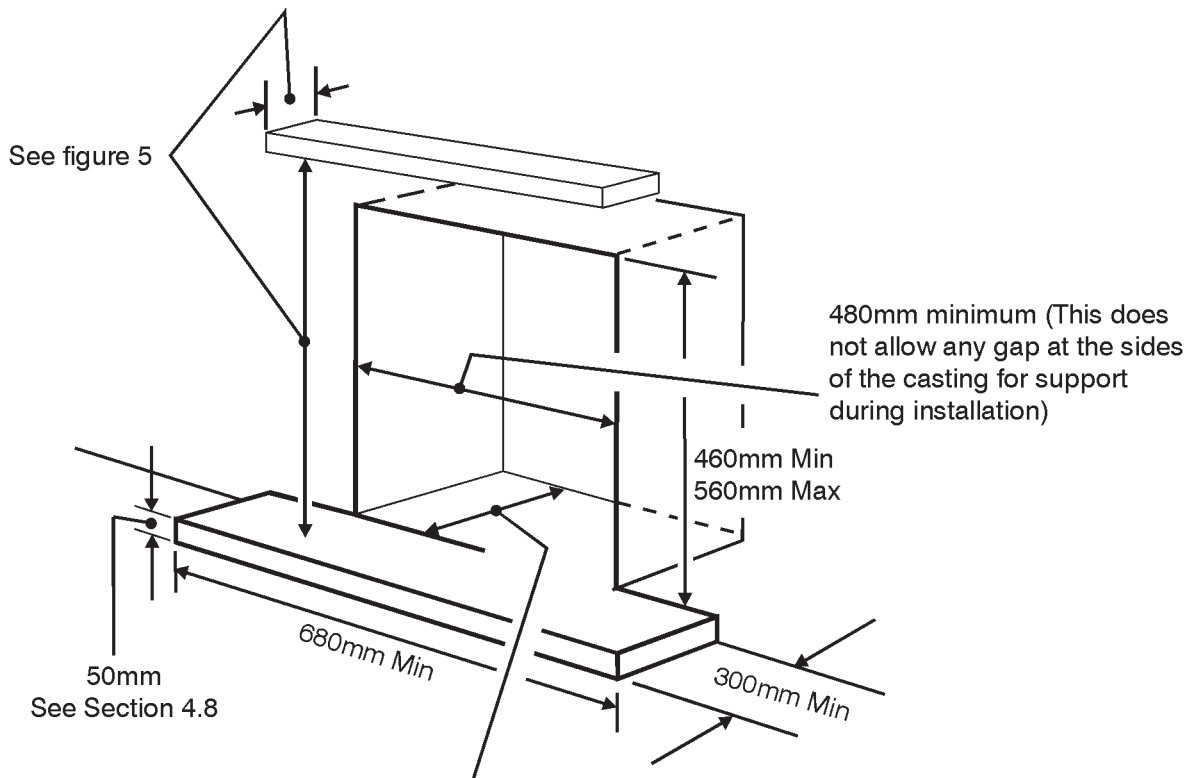

Figure 1. Hearth and fireplace opening



340mm minimum with casting completely behind the front of the fireplace opening.
270mm minimum with incandescent area level with the front of the fireplace opening
(In both cases the burner must be positioned so that the burner tray trim is touching the lower inside face of the casting).

Figure 2. Hearth and fireplace opening for installations using the **SPANISH BASKET CASTING ONLY** (See section 4.8)

4.2 Ventilation requirements.

Normal adventitious ventilation is usually sufficient to satisfy the ventilation requirements of this appliance. In GB reference should be made to BS 5871 Part 2 and in IE reference should be made to the current edition of IS 813 “Domestic Gas Installations” which makes clear the conditions that must be met to demonstrate that sufficient ventilation is available.

4.3 The Atmosphere sensing device (ASD).

The appliance is fitted with an A.S.D (Atmosphere sensing device). If the appliance closes down after a period of operation for no apparent reason, the consumer should be informed to stop using the appliance until the installation and appliance have been thoroughly checked. The A.S.D will shut the appliance down if an unacceptable amount of harmful products of combustion accumulate. Under no circumstances should the A.S.D be altered or bypassed in any way. Only a genuine manufacturers replacement part should be fitted. The individual A.S.D components are not replaceable.

4.4 Fireguard requirements.

A fireguard complying with BS 8423 should be fitted for the protection of young children, the elderly, or the infirm.

4.5 Room considerations.

4.5.1 This appliance must not be installed in any room that contains a bath or shower or where steam is regularly present.

4.5.2 An extractor fan may only be used in the same room as this appliance, or in any area from which ventilation for the appliance is taken, if it does not affect the safe performance of the appliance. Note the spillage test requirements detailed further on in this manual. If the fan is likely to affect the appliance, the appliance must not be installed unless the fan is permanently disconnected.

4.5.3 Note that soft wall coverings (e.g. embossed vinyl, etc.) are easily affected by heat. They may scorch or become discoloured when close to a heating appliance. Please bear this in mind when installing.

4.6 Chimney preparation.

4.6.1 If the appliance is intended to be installed to a chimney that was previously used for solid fuel, the flue must be swept clean prior to installation. All flues should be inspected for soundness and freedom from blockages.

4.6.2 Any chimney damper or restrictor should be removed. If removal is not possible, they must be secured in the open position.

4.6.3 The flue must not be used for any other appliance or application.

INSTALLER GUIDE

4.7 Fireplace preparation.

4.7.1 If the fireplace opening is an underfloor draught type, it must be sealed to stop any draughts.

4.7.2 The surface of the hearth must be sufficiently flat to enable the bottom of the front surround and the bottom front cover to be aligned horizontally. Any excessive unevenness (uneven tiles, Cotswold stone, etc.) should be rectified.

4.7.3 If the appliance is to be fitted against a wall with combustible cladding, the cladding must be removed from the area shown in figure 3.

4.7.4 If the fireplace opening is greater than the acceptable dimensions given in this guide, do not use the back of a fire surround or marble to reduce the opening. This may cause cracking of the surround back or marble.

4.7.5 The appliance must not stand on combustible materials or carpets.

4.8 The hearth.

The appliance must be mounted behind a non-combustible hearth unless the conditions of section 4.10.1 are met (N.B. conglomerate marble hearths are considered as non-combustible). The appliance can be fitted to a minimum class "O" 100°C surround. The hearth material must be at least 12mm thick. The periphery of the hearth (or fender) should be at least 50mm above floor level to discourage the placing of carpets or rugs over it (See figure 1 or 2).

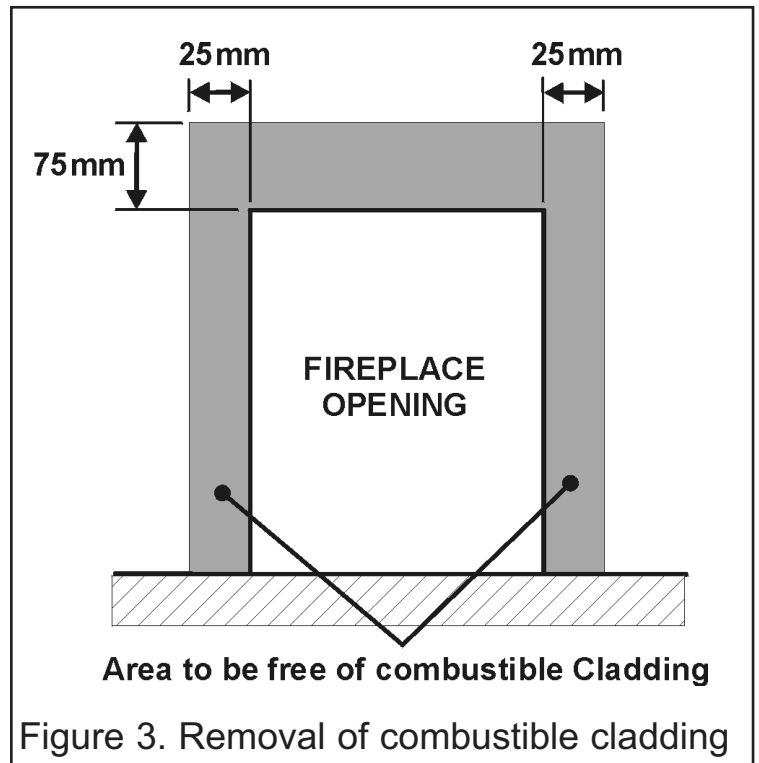

Figure 3. Removal of combustible cladding

INSTALLER GUIDE

4.9 Fireplace clearances.

4.9.1 Combustible side projections up to 75mm forward of the fixing plane of the fire are to be a minimum of 125mm from the fireplace opening (See figure 4).

4.9.2 Combustible side projections greater than 75mm forward of the fixing plane of the fire are to be a minimum of 178mm from the fireplace opening (See figure 4).

4.9.3 Non-combustible side projections to be 75mm from the fireplace opening (See

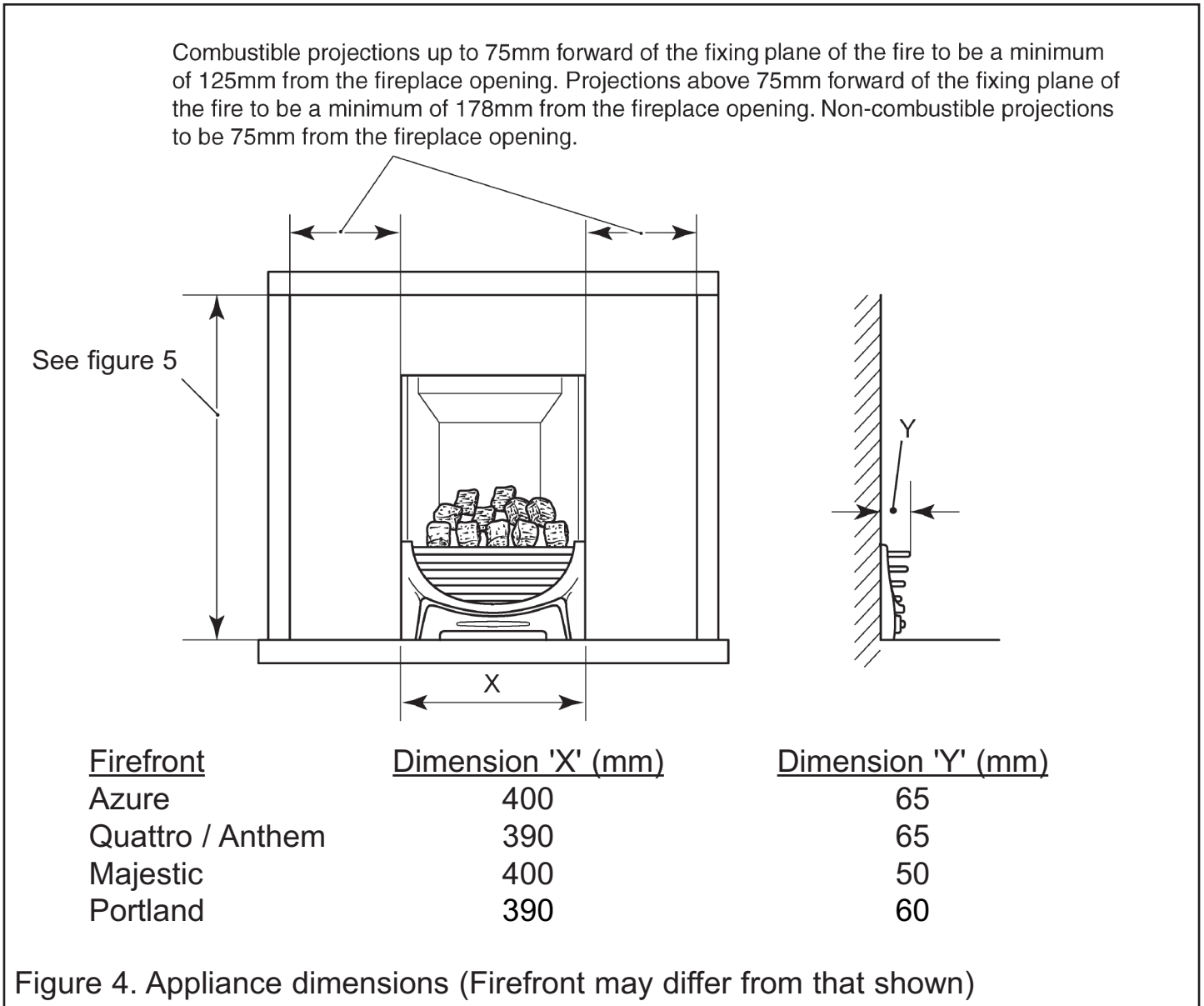

figure 4).

4.9.4 The minimum height from the base of the fireplace opening to the underside of any shelf made from wood or other combustible materials is as follows: -

- For a shelf up to 150mm deep
Minimum height = 860mm.
- For a shelf deeper than 150mm
860mm + 12.5mm for every 25mm depth over 150mm

(See figure 5).

INSTALLER GUIDE

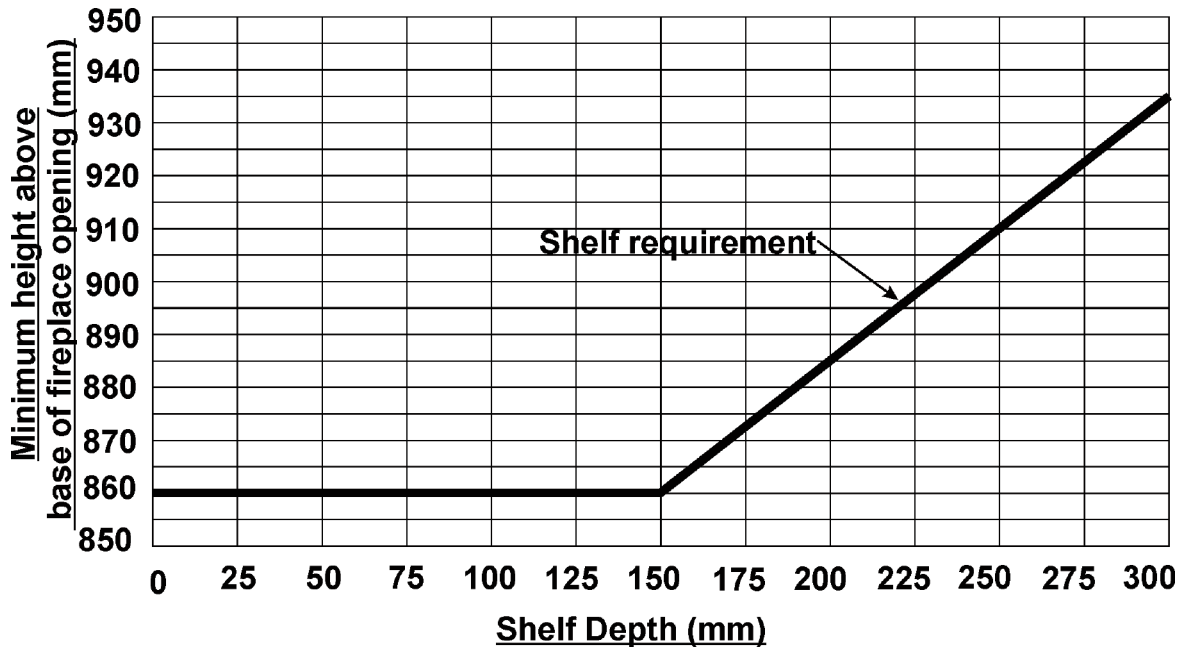

Figure 5. Combustible shelf clearances

4.10 Installation options.

In the United Kingdom, as supplied the appliance can be installed in the following situations: -

4.10.1. 'Hole-in-the-wall' Installations

For installation **without** the **Spanish basket** casting.

- It is recommended that a hearth should be installed as in figure 1.

For installation **with** the **Spanish basket** casting.

- It is recommended that a hearth should be installed as in figure 2.

For installation **with** and **without** the **Spanish basket** casting.

- If a hearth is not fitted or if a reduced depth hearth is fitted, the fire must be installed so that the distance from the base of the fireplace opening in the wall to the finished floor level is at least 75mm. Where there is no floor covering or carpet and the floor is of a type that is likely to be covered in such a way in the future then the distance from the base of the fireplace opening in the wall to the finished floor level should be increased to at least 150mm.

- If the lower part of the fascia (the firefront) is free standing, the recommended reduced hearth depth is 100mm. This is necessary to support the firefront.

- To protect from the risk of burns and ignition of clothing a tactile separator shall be used. The hearth detailed in section 4.8 meets the requirements for a tactile separator. If this is not used then a 680mm long fender, kerb, horizontal bar, or other barrier, being fixed not less than 50mm above floor level and positioned 300mm in

INSTALLER GUIDE

front of the fixing plane of the fire will meet the requirement.

The tactile separator can also take the form of a canopy, being fixed not more than 1000mm above floor level and positioned 300mm in front of and 150mm beyond the edge of any naked flame or incandescent part of the fire bed.

For installations without the Spanish basket casting.

- To a fireplace complete with surround and hearth as shown in figure 1 and complying with BS1251.

For installations with the Spanish basket casting.

- To a fireplace complete with surround and hearth as shown in figure 2 and complying with BS1251.

For fireplace openings having dimensions different to those shown in figure 2 refer to figure 6 and BS 5871-Part 3 for flue sizes.

Into a fireplace that has a fireback of nominal size 400mm and conforming to BS1251.

Into a Replacement Chair Brick as below: -

- **Quattro, Anthem, Majestic and models not supplied with a firefront**

Into a Replacement Chairbrick. Part number 0552311.

- **Azure model**

Into a B&Q Replacement Chairbrick. Part number 0552301.

Suitable flues and minimum flue sizes are as follows: -

225mm x 225mm conventional brick flue.

175mm diameter lined brick or stone flue.

200mm diameter factory made insulated flue manufactured to BS4543.

175mm diameter flue pipe. See BS6461 Part 1 for suitable materials.

The minimum effective height of the flue must be 3m.

The flue must not be used for any other appliance or application.

4.11 Propane appliances.

Propane gas appliances must not be installed in a room that is built entirely below ground level (See BS 5871 Part 3).

INSTALLER GUIDE

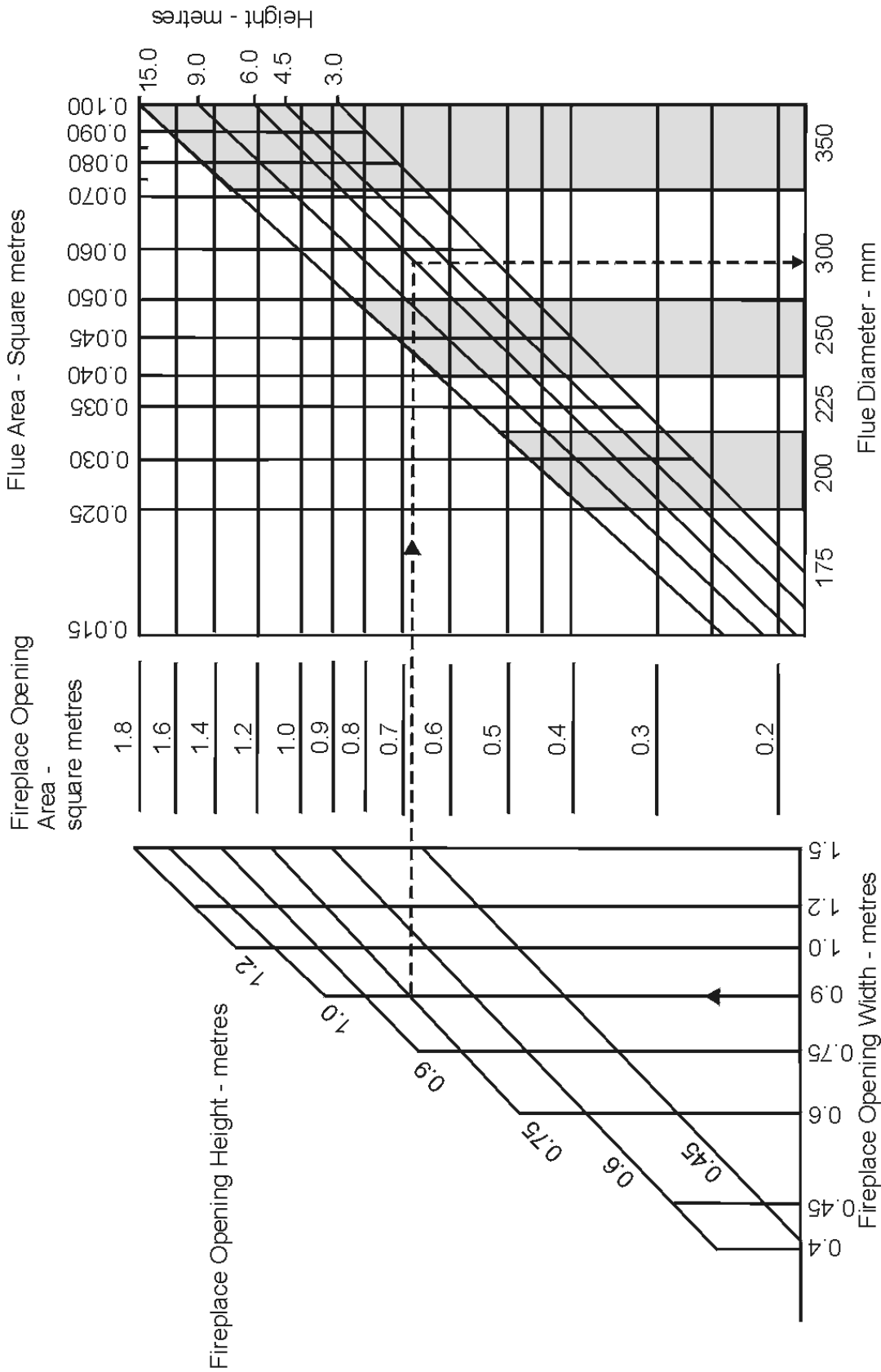

Figure 6. Flue sizing table.

EXAMPLE

Fireplace opening is 0.9m wide x 0.75m high = 0.68m². Then for flue height 6.0m, use a 300mm diameter flue.

NOTE 1 Where choice is possible, the smallest diameter flue should be used. Large diameter flues, particularly of short length, will be conducive to downdraught and therefore spillage.

NOTE 2 In the case of fireplace openings served by the above chart, a fireplace opening of greater width than height will be less likely to spill than one of width and height, despite their having the same fireplace opening areas.

INSTALLER GUIDE

5. UNPACKING

Contents:

- 1 Burner assembly.
- 1 Nut & olive for 8mm inlet pipe.
- 4 Screws.
- 4 Plastic screw plugs.
- 1 Fuel bed matrix support plate.
- 2 Self tapping screws.
- 1 Inlet 'T' connector / elbow.
- 1 Ceramic fuel effect pack.
- 1 Burner tray trim (Not fitted to Anthem or Quattro models).

For models supplied with a firefront

- 1 Firefront and ash pan cover (Where applicable).

Carefully remove the contents. Take special care in handling the ceramic fuel effect pieces. Check that all the listed parts are present and in good condition.

6. INSTALLATION OF APPLIANCE

INSTALLATION

6.1 Fireplace size.

The fireplace must comply with the requirements described in section 4.

6.2 Fireplace flue pull.

Visually inspect the flue for any obstruction, and that a smooth transition from the fireplace opening into the flue is available. Close all doors and windows in the room in which the appliance is to be installed. After confirming with a match that smoke is drawn into the flue, light a 13 gram smoke pellet and check that there is a definite flow through the flue. Verify outside that the smoke exits from one terminal only and that the termination is suitable. Observe, where possible, upstairs rooms and loft spaces for signs of escaping smoke indicating a defective flue. If there is not a definite flow warm the flue for a few minutes and repeat the smoke pellet test. If there is still no definite flow the flue may need remedial work – **Do not fit the appliance until there is a definite flow through the flue.**

6.3 Installation of the burner unit

6.3.1 Prior to installation of the burner the rear ceramic support bracket must be fitted (See figure 7). Secure with two self-tapping screws but do not over-tighten as these will have to be removed again when installing the burner.

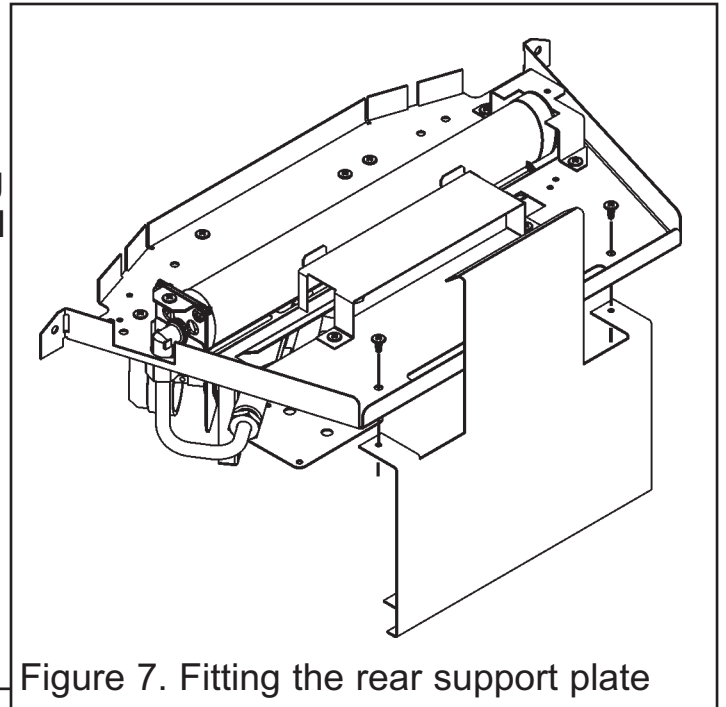

Figure 7. Fitting the rear support plate

6.3.2 Burner Tray trim.

- The trim is **not** to be fitted to Anthem or Quattro models.
- The fire is supplied with a burner tray trim. Fit the trim as in figure 8.

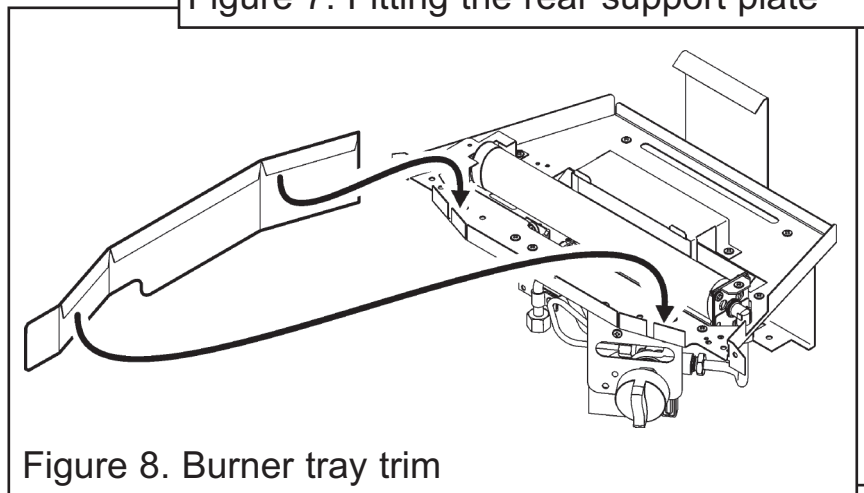

Figure 8. Burner tray trim

6.3.3 Burner Positioning.

- The two tags at the side of the burner can be folded against the side of the burner tray. This may be required for installations where the width of the fireplace opening is restricted or when fitting into a 'Spanish Basket' casting (See figure 9).

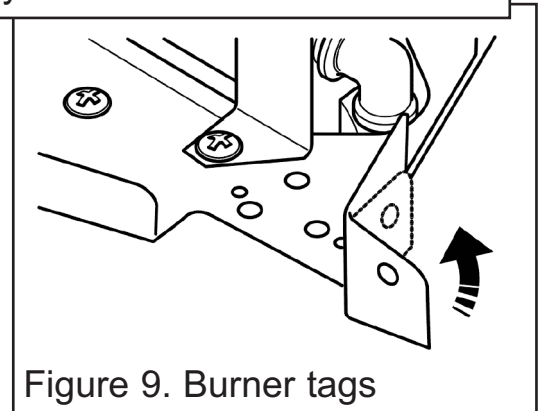

Figure 9. Burner tags

INSTALLER GUIDE

For installations without the 'Spanish Basket' casting.

- Place the burner unit centrally within the fireplace opening. Position the burner to the rear of the opening, this may be moved forward providing the front of the burner tray trim does not protrude beyond the front plane of the fireplace opening by more than 33mm (See figure 10).

For installations with the 'Spanish Basket' casting.

- Place the casting centrally within the fireplace opening. Position the casting to the rear of the opening.
- Place the burner unit inside the casting.
- It is important that the burner tray trim touches the inner front face of the casting. This will give the customer greater access to the control knob.
- The casting and burner may be moved forward providing the front of the burner tray trim does not protrude beyond the front plane of the fireplace opening by more than 33mm (See figure 10).

6.3.4 Locating the burner.

! Mark onto the floor, the position of the two fixing holes in the front fixing bracket (See figure 11).

- Without disturbing the burner, remove the two screws at the rear of the burner tray (See figure 12). These secure the rear ceramic support bracket to the burner tray.
- Hold the ceramic support bracket in place. Lift and remove the burner.
- The base of the rear ceramic support bracket has two holes. Mark their positions onto the floor.
- Drill all four marked hole positions with a

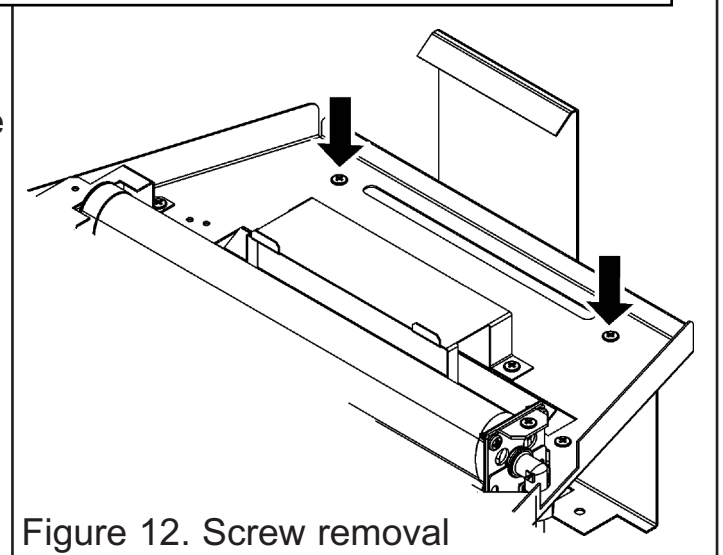
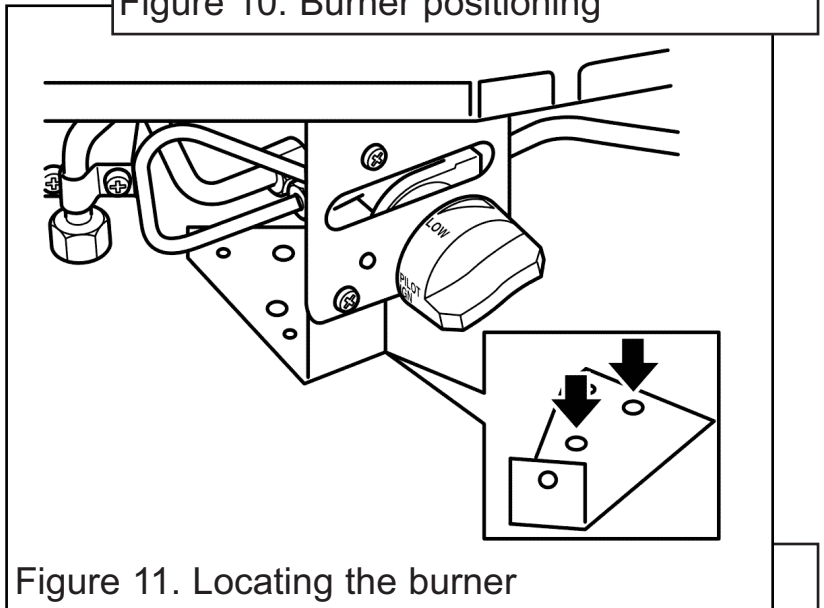
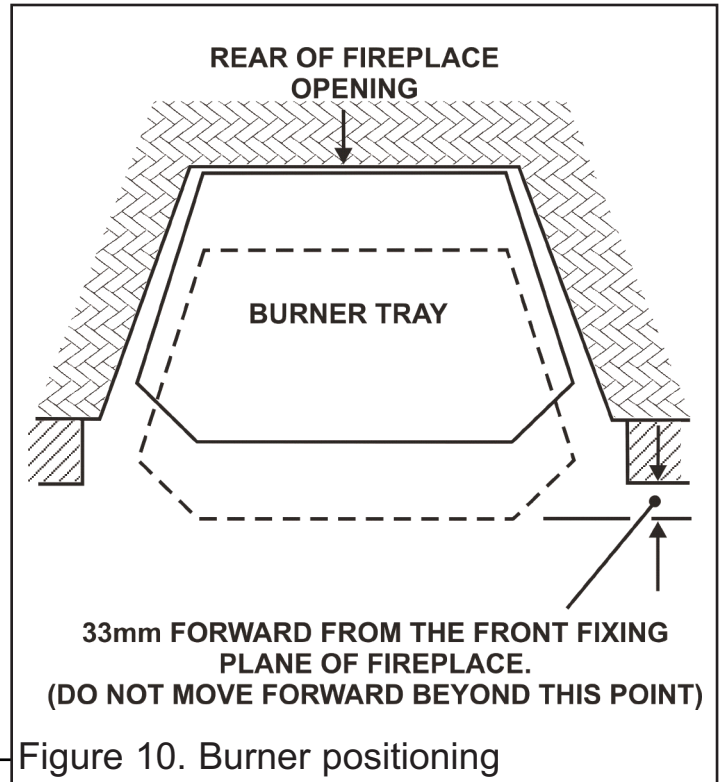

INSTALLER GUIDE

6mm masonry drill bit.

- Insert a wooden plug into each hole.
- Unscrew the fixing bracket from the front support leg of the burner.
- Using 4 screws secure the front fixing bracket and ceramic support bracket to the base of the floor.
- Locate the burner onto the rear ceramic support bracket ensuring that the control knob bracket sits in front of the front support bracket. Secure the burner to the ceramic support bracket using the two screws removed previously. Secure the burner to the front securing bracket using the screw removed previously.

7. BURNER AND SUPPLY PIPE INSTALLATION

A nut and olive is provided for an mm pipe inlet connection directly to the gas control. The inlet 'T' connector / elbow can be rotated to allow a connection from any direction. The inlet 'T' connector includes a valve for isolating the gas supply. Note that the centre of the appliance inlet 'T' connector is 25mm above the fireplace floor. The inlet 'T' connector should be fitted to the supply pipe at this stage.

The supply pipe must be rigid material. Flexible pipe must not be used. Connect the supply line to the appliance.

Turn on the gas supply and pressure check the installation pipework for gas soundness. In the United Kingdom (GB) check in accordance with the current edition of BS 6891. In the Republic of Ireland check in accordance with the current edition of IS 813 "Domestic Gas Installations".

7.1 Preliminary burner checks.

Some burner operations can be checked at this stage. Checking now will mean that less disassembly will be required if any problems are found. ***A full check should still be made, however, after final installation.***

7.1.1 Lighting the fire

If closed, open the isolating inlet 'T' connector. Depress the control knob and slowly rotate it anticlockwise to the pilot ignition position. A 'click' will be heard as the integral piezo operates. A spark should be seen between the electrode and pilot tip. Turn the control knob clockwise to the 'Off' position. Repeat this operation until a flame appears at the pilot. There may be a delay before the pilot lights due to air being purged from the system. When a flame appears at the pilot keep the control knob depressed and hold the pilot ignition position for ten seconds. When the control knob is released the pilot flame should remain lit.

7.1.2 Operating the burner.

When the pilot burner is operating properly, gradually turn the control knob anticlockwise to 'HIGH' (Depress the knob slightly to get past the pilot ignition position). The main burner should now light. Depress the control knob slightly to release from the 'HIGH' position and turn back (clockwise) to 'LOW'. While turning, the burner

INSTALLER GUIDE

flames should gradually become lower but remain alight. Depress the control knob slightly to release from the 'LOW' position and turn back (clockwise) to the 'pilot ignition' position. The main burner should extinguish but the pilot should remain alight. Depress the control knob slightly and turn back (clockwise) to turn OFF.

This will extinguish the pilot.

7.1.3 Checking the inlet pressure.

The appliance is pre-set to give the correct heat input at the inlet pressure shown in section 3 of this manual. No adjustment is necessary.

1. Ensure that the fire is OFF. Check the inlet pressure by fitting a pressure gauge at the test point. The test point is on the inlet 'T' connector (See figure 13). Check the pressure with the appliance alight and set at maximum output.

2. After checking, turn off the appliance. Remove the pressure gauge and replace the test point sealing screw.

3. Relight the appliance. Turn to the maximum output position and test around the sealing screw for gas soundness with a suitable leak detection fluid.

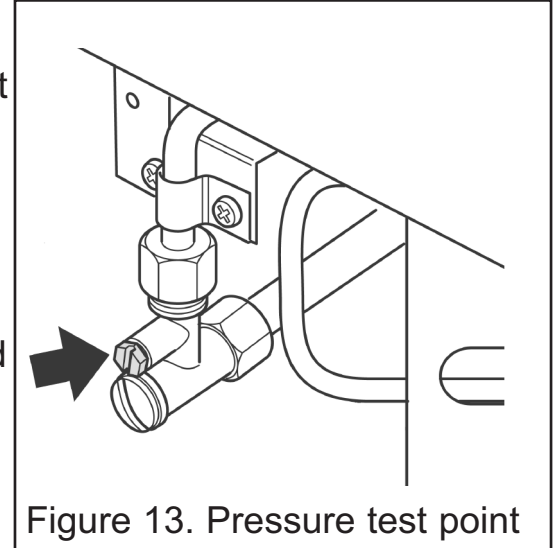

Figure 13. Pressure test point

8. FITTING THE FIREFRONT

Before fitting the fascia ensure that the information on the back pages of the owner guide have been completed.

8.1 For models NOT supplied with a firefront.

A slotted firefront with a **minimum** free area as shown in figure 14 must always be used.

8.2 For models SUPPLIED with a firefront.

The firefront supplied with this fire has been tested and found to be satisfactory for use with this fire. The open area may differ slightly from that shown in figure 14.

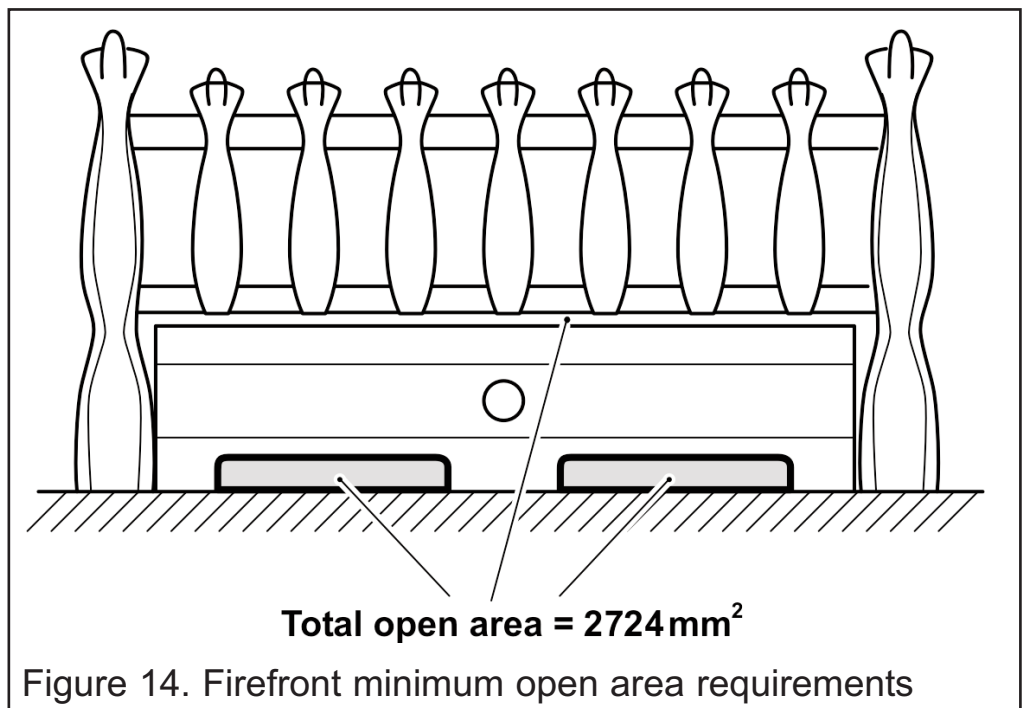

Figure 14. Firefront minimum open area requirements

INSTALLER GUIDE

Place the decorative firefront on the hearth and central to the appliance.

Quattro / Anthem firefront only.

1. The Quattro / Anthem firefront is fitted with a set of fixing brackets. Each bracket has two threaded holes. As supplied the top threaded hole should be fitted with a 25mm long machine screw. Remove the machine screw and locate to the threaded hole below.
2. The screw should be set at a distance of 7mm (Measured from the surface of the bracket to the underside of the screw head). Adjust the screw to this distance (See figure 15).
3. Locate the firefront as in figure 16. The screw heads should locate into the slots in the burner tray.
4. The lower "ash pan" casting should be located as in figure 17.

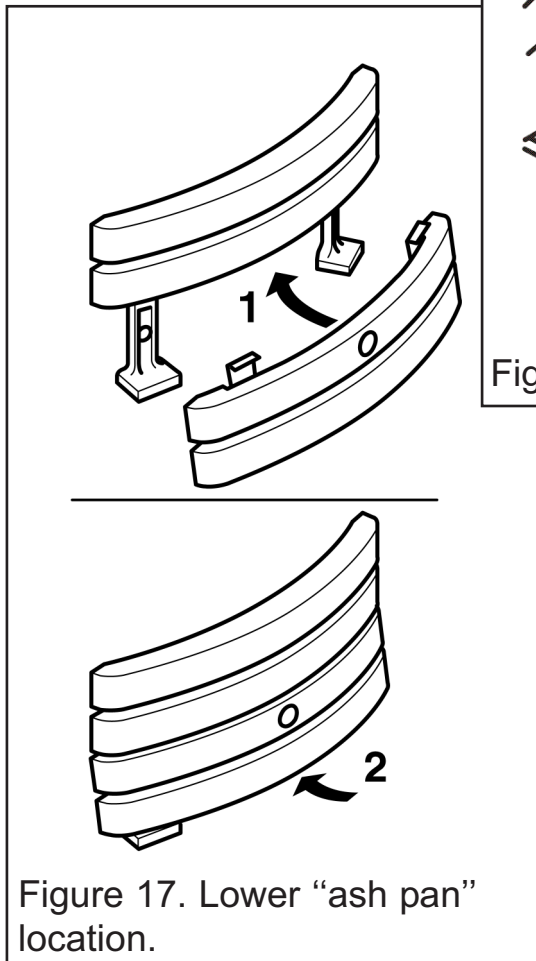
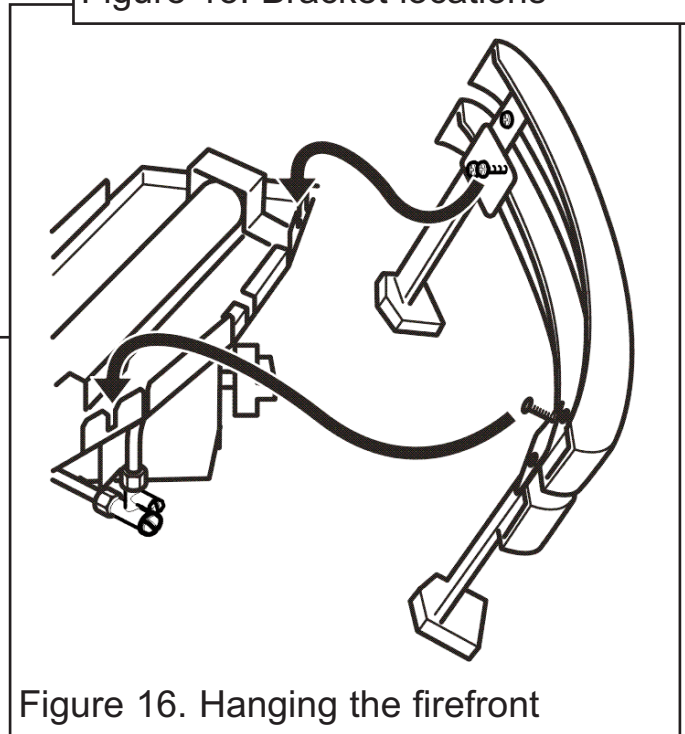
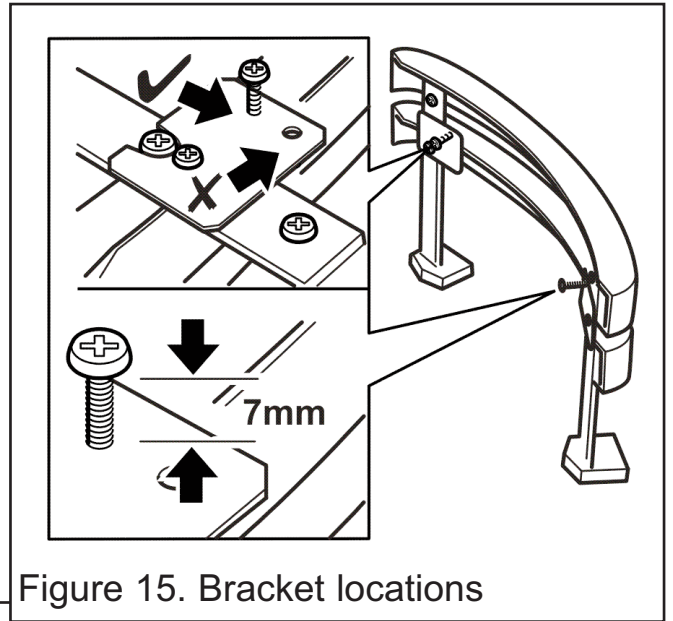

INSTALLER GUIDE

9. FITTING THE CERAMIC FUEL EFFECT

The installer and owner guide for the ceramic fuel effect is supplied with the ceramic fuel effect. It is important that the fitting guide for the ceramic fuel effect be placed inside or attached to this guide and handed to the customer following completion of the 'Final review' section.

10. FULL OPERATING CHECKS

10.1 Spillage check.

- A spillage check must be made before leaving the installed appliance with the customer. Make this with all the ceramic fuel effect pieces and firefronts / castings are in position (See figure 18).

- Close all doors and windows in the room containing the appliance. Light the appliance and set the control to the 'HIGH' position. Leave the appliance on for five minutes. See lighting instructions within section 7 of this guide.

- The end of the smoke match should be level with the front face of the fireplace opening.

- The installation is satisfactory if the smoke is drawn into the fireplace opening. If the smoke is not drawn into the fireplace opening, leave the appliance alight at the maximum setting for a further ten minutes and then repeat the test. If smoke is still not drawn into the appliance **disconnect the appliance and seek expert advice.**

- If the above test is satisfactory, open all internal connecting doors, hatches, etc. in the room. Keep all doors and windows that open to the outside of the building closed. Switch on any extractor fan installed in the same room as the appliance or a connecting room. Open all doors and other openings between the fan and the appliance. Recheck for spillage as above. If the smoke is drawn into the appliance, continue with the installation. If the test is not satisfactory, **disconnect the appliance and advise the customer of the cause of failure.**

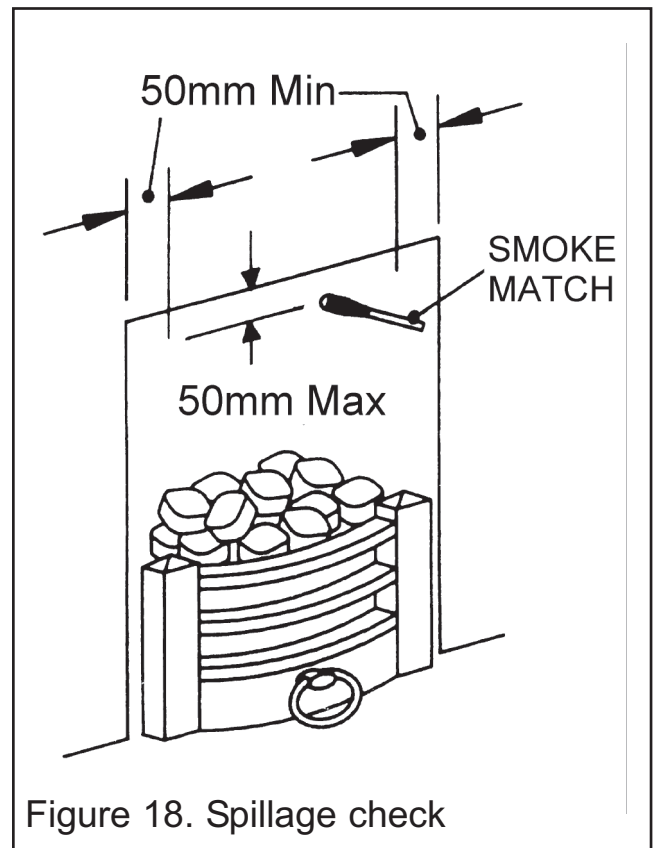

INSTALLER GUIDE

10.2 Flame Supervision & Spillage Monitoring System.

The pilot unit incorporates a system that will automatically shut off the gas supply if the pilot flame goes out or if there is insufficient oxygen due to spillage or lack of ventilation.

Check that the system operates properly as follows:

- Light the appliance. Set at the "HIGH" position and leave for one minute.
- Turn back to "OFF" to extinguish the pilot. Note the time when the pilot goes out.

Listen for a snap sound at the gas tap. Note the time when the sound is heard. An electromagnetic valve shutting off the gas supply through the tap causes this sound. The valve is located in the body of the tap. The valve should operate within 60 seconds of the pilot going out. If the valve does not operate within this time limit do not allow the appliance to be used until the fault has been corrected.

This monitoring system must not be adjusted, bypassed or put out of operation. This monitoring system, or any of its parts, must only be exchanged using authorised parts.

10.3 Final Review.

1. ENSURE THAT YOU HAVE COMPLETED THE INFORMATION IN THE WARRANTY AND SERVICE SECTION OF THE OWNER GUIDE (See last pages of the OWNER guide).

2. Visually inspect the appliance. Clean off any marks incurred during installation.

3. Hand this guide to the customer.

4. Stress that no extra ceramic fuel effect pieces must be added over and above those supplied with the appliance and that any replacements must only be authorised spares. Warn that ignoring this advice could cause incomplete clearance of the products of combustion with consequent health hazards.

5. Advise the customer how to operate the appliance. Point out that lighting instruction details are contained within the owner guide.

6. Explain that this appliance is fitted with an atmosphere-sensing device, ODS pilot unit that will automatically shut off the supply of gas to the fire if, for any reason, the flames go out. It will also shut off the gas supply if the flue is blocked or if there is not enough ventilation. If this device does operate or if the fire is turned off accidentally or intentionally, always wait three minutes before attempting to relight.

7. Advise the customer that the fire front and ceramic fuel effect pieces can be cleaned as described in the owner guide and that the ceramic fuel effect pieces must be replaced as described in the installer and owner guide for the ceramic fuel effect.

8. Recommend that the appliance should be serviced and the chimney inspected by a competent person at least annually.

11. SERVICING & PARTS REPLACEMENT

Always turn off the gas supply and allow to cool completely before commencing any servicing (The appliance inlet 'T' connector incorporates an isolating valve).

It is recommended that, at least once a year, the appliance is disconnected and the fireplace opening checked and cleared of any debris.

This product uses fuel effect pieces containing Refractory Ceramic Fibres (RCF), which are man-made vitreous silicate fibres. Excessive exposure to these materials may cause irritation to eyes, skin and respiratory tract.

Consequently, it is important to take care when handling these articles to ensure that the release of dust is kept to a minimum. To ensure that the release of fibres from these RCF articles is kept to a minimum, during installation and servicing we recommend that you use a HEPA filtered vacuum to remove any dust and soot accumulated in and around the fire before and after working on the fire. When replacing these articles we recommend that the replaced items are not broken up, but are sealed within a heavy duty polythene bag, clearly labelled as RCF waste. RCF waste is classed as a stable, non-reactive hazardous waste and may be disposed at a landfill licensed to accept such waste. Protective clothing is not required when handling these articles, but we recommend you follow the normal hygiene rules of not smoking, eating or drinking in the work area and always wash your hands before eating or drinking.

- Check that the appliance is clean and that soot or debris is not blocking the gaps between the ceramic fuel effect pieces causing an imperfect flame.
- Check that soot or debris is not impairing the electrode spark or pilot burner.
- Check that soot or debris is not blocking any of the slots in the main burner.
- After servicing, make sure that the ceramic fuel effect pieces are replaced correctly as described in the installation instructions.
- **Always test for gas soundness and spillage after servicing the appliance.**

11.1 Checking the aeration setting of the burner.

1. The aeration shutter is factory set and should not require adjustment. If the shutter is not as shown in figure 19 and requires adjustment, loosen the two aeration shutter screws, slide the aeration shutter to the position shown in figure 19 and tighten the fixing screws.

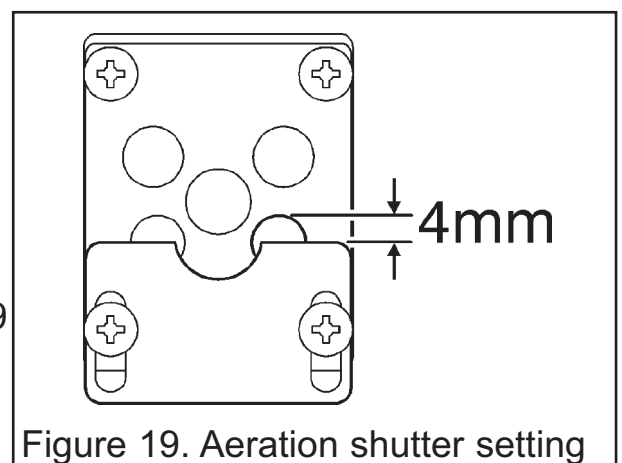

INSTALLER GUIDE

11.2 To remove the complete burner unit.

1. Remove the firefront and place in a safe position.
2. Remove the ceramic fuel effect.
3. Close the valve in the inlet 'T' connector / elbow.
4. Disconnect the appliance from the inlet 'T' connector.
5. Remove the front leg fastening screw. This is located to the left of the control knob.
6. Lift the burner out of the fireplace opening.
7. Replace in the reverse order.

11.3 To remove the pilot unit.

1. Remove the burner unit (See section 11.2).
2. Detach the pilot pipe from the pilot unit.
3. Detach the thermocouple from the gas valve.
4. Detach the electrode lead from the underside of the electrode tab.
5. Remove the two screws securing the pilot unit (See figure 20).
6. Refit in the reverse order.

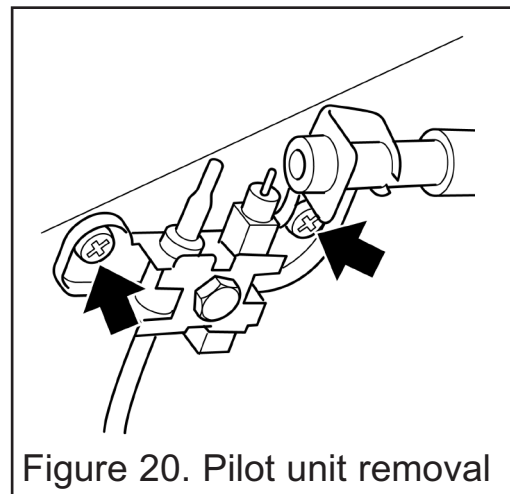

Figure 20. Pilot unit removal

Note: The pilot unit is an atmosphere sensing device. It must be replaced as a whole assembly. Its individual components are not separately replaceable.

11.4 To remove the gas valve.

(See figure 21).

1. Remove the burner unit (See section 11.2).
2. If lying the burner on its back, ensure that the work surface is suitably protected. This will avoid damage to the work surface. Turn the burner unit upside down. Detach the thermocouple from the tap.
3. Detach the pilot pipe from the tap.
4. Detach the inlet pipe.
5. Detach the injector pipe.
6. Detach the electrode lead from the base of the electrode.
7. Remove the control knob by pulling forward.
8. Remove the thermocouple by unscrewing the thermocouple nut at the gas valve.
9. Remove the hexagonal nut securing the gas valve to the mounting bracket.
10. Remove the gas valve.
11. Refit in the reverse order.

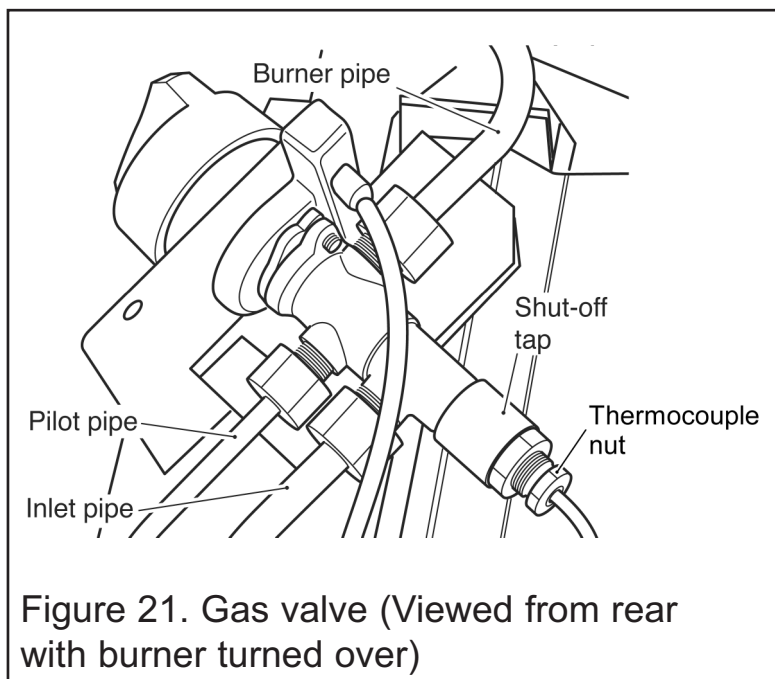

Figure 21. Gas valve (Viewed from rear with burner turned over)

INSTALLER GUIDE

11.5 To remove the piezo generator.

1. Remove the gas valve as in section 11.4.
2. Make sure that the tap is in the off position.
3. Remove the circlip holding the piezo unit to the tap. Remove the piezo unit.
4. Replace in the reverse order.

11.6 To grease the control tap.

1. Detach the tap and remove the piezo generator as section 11.5 making sure that the tap is in the off position.
2. Remove the two screws from the head of the tap. Remove the niting head and spindle complete with collar and spring.
3. Note the position of the slot in the plug-mark its position on the tap body.
4. Remove the plug rotating slightly while pulling.
5. Clean and grease the plug lightly with suitable grease. Do not apply excessive grease. Particularly, make sure that the gas ports in the tap are not restricted by grease.
6. Push the plug into the tap body and position the slot in line with the mark previously made on the tap body.
7. Reassemble the niting head and spindle complete with collar and spring making sure that the components are correctly engaged. Check the operation of the tap.
8. Refit the piezo generator.

11.7 To replace the burner.

(See figure 22).

1. Remove the burner unit (See section 11.2).
2. Support the elbow injector and unscrew the injector nut.
3. Remove the two screws from the burner clamping plate (See figure 22).
4. Lift the right hand side of the burner, slide it to the right and lift clear.
5. Refit in reverse order.

11.8 To remove the main burner injector.

(See figure 23).

1. Remove the burner (See section 11.7).
2. Remove the burner clamping screw (See figure 23).
3. Unscrew the injector from the burner.
4. Refit in the reverse order.

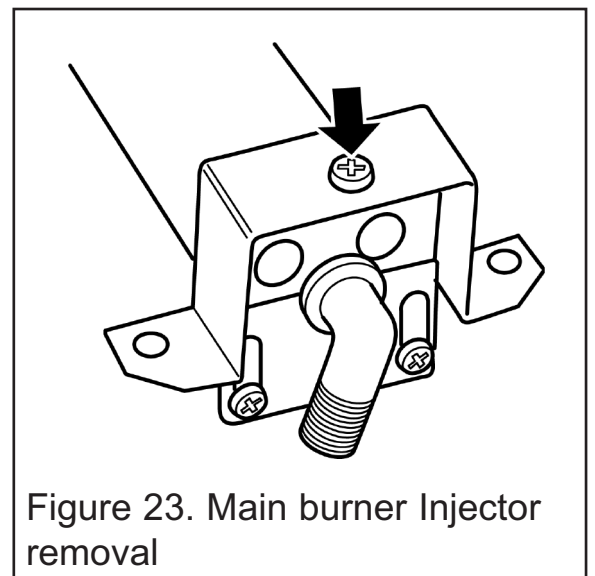
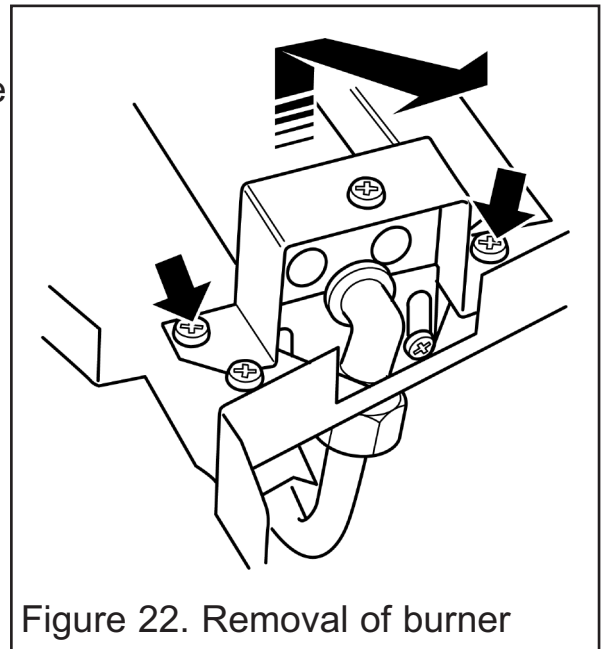

OWNER GUIDE

FOR WARRANTY AND SERVICE INFORMATION
SEE PAGES 38 TO 43

OWNER GUIDE

LIST OF CONTENTS

<u>Section</u>	<u>Page</u>
SAFETY	31
GAS CONSUMPTION	32
APPLIANCE DIMENSIONS	33
OPERATING THE FIRE	34
The Oxysafe flame sensing & flue blockage safety system.	34
To light the fire.	34
Lighting with a taper.	35
CLEANING	36
Metal parts.	36
Ceramic fuel effect.	36
Burner.	36
CERAMIC FUEL EFFECT REFITTING	37
FITTING THE LOWER FIREFRONT	37
MAINTENANCE	38
Regular maintenance.	38
WARRANTY, SERVICE AND BENCHMARK	38-43
BENCHMARK COMMISSIONING CHECKLIST	41
BENCHMARK SERVICE RECORD	42
SERIAL NUMBER LABEL	43

This gas fire is designed to meet the most stringent quality, performance and safety requirements to provide you with many years' trouble-free service.

This guide aims to improve your understanding and appreciation of your gas fire by providing simple and informative instructions to ensure that you benefit from the excellent performance and features it has to offer.

OWNER GUIDE

SAFETY

IF YOU SMELL GAS

- **DON'T SMOKE.**
- **EXTINGUISH ALL NAKED FLAMES.**
- **DON'T TURN ELECTRICAL SWITCHES ON OR OFF.**
- **TURN OFF THE GAS SUPPLY AT THE METER OR TANK AS APPROPRIATE.**
- **OPEN DOORS AND WINDOWS TO GET RID OF THE GAS.**
- **IMMEDIATELY CALL THE GAS EMERGENCY SERVICE FROM A NEIGHBOURS PHONE - SEE YOUR LOCAL TELEPHONE DIRECTORY.**

Do have the fire installed by a competent person. In the United Kingdom, installation must be in accordance with the latest edition of the Gas Safety (installation & use) Regulations. In the Republic of Ireland, installation must be in accordance with all national and local regulations in force.

Do have the chimney swept prior to installation if it was previously used for solid fuel.

Do have the fire installed in accordance with the installation guide.

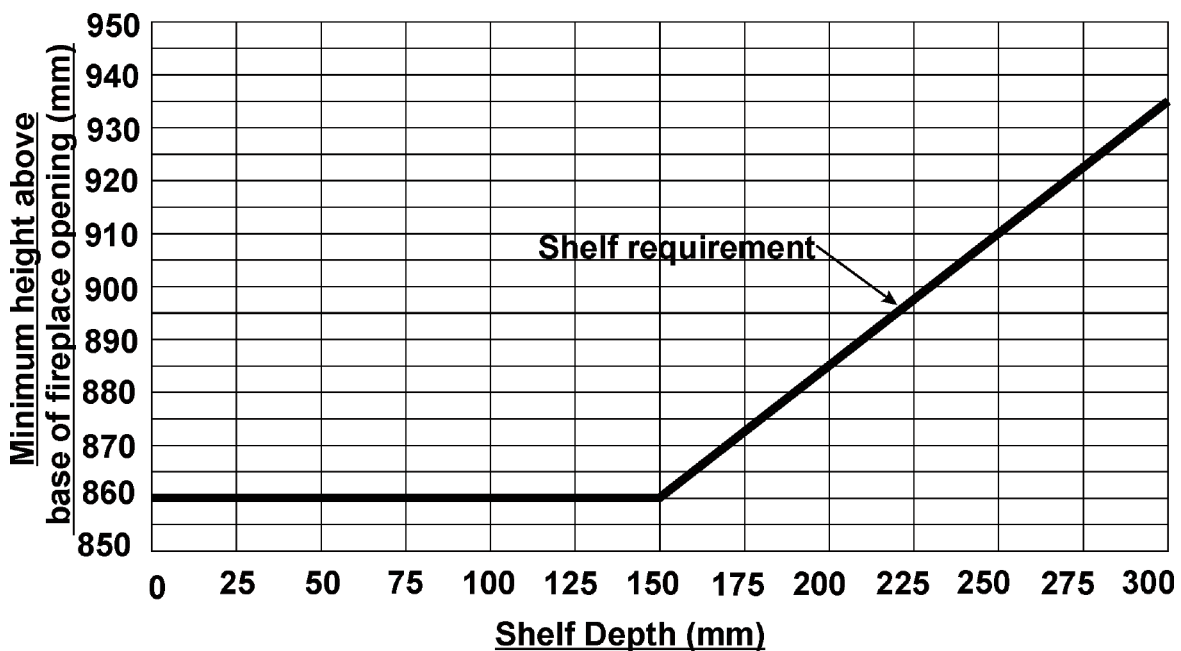

Figure 1. Combustible shelf clearances

Do provide a minimum clearance of 860mm from the base of the fireplace opening to any shelf made of wood or other combustible material where the shelf is not more than 150mm deep. For a shelf deeper than 150mm, add 12.5mm to the clearance for every 25mm of additional shelf depth (See figure1).

OWNER GUIDE

Do provide a suitable guard that complies with BS 8423 for the protection of young children, the elderly, the infirm and pet animals. (Although this fire conforms to all the applicable standards, it is a heating appliance and certain parts of its surface will become hot).

Do wait three minutes before attempting to relight if the fire is switched off or the flames are extinguished for any reason. (Your fire is fitted with a safety device that will automatically shut off the gas supply to the fire if, for any reason, the flames go out).

Do get advice about the suitability of any wall covering near your fire. Soft wall coverings (e.g. embossed vinyl, etc.) which have a raised pattern are easily affected by heat. They may, therefore, scorch or become discoloured when close to a heating appliance. Please bear this in mind whenever you are considering redecorating.

Do provide a minimum side clearance as detailed in figure 2. Please bear this in mind if ever you are considering altering the room.

Don't hang clothing, towels or any other fabrics over the front of the fire.

Don't add any extra ceramic fuel effect pieces above the number stated in the installer and owner guide supplied with the ceramic fuel effect. This should have been placed inside or attached to this guide by the installer. This could cause incomplete combustion and consequent safety hazard.

Don't put paper or any other material on the fire.

Don't place any combustible material (rugs, carpet, plastic tiles, etc.) on the hearth.

Don't attempt to clean or service the fire until it has been switched off and allowed to cool completely.

GAS CONSUMPTION

Model 939

Has a maximum natural gas input of 6.85kW (Gross)

Has a minimum natural gas input of 2.3kW

Model 939 when converted using kit number 0595211

Has a maximum propane gas input of 6.7kW (Gross)

Has a minimum propane gas input of 4.0kW

OWNER GUIDE

APPLIANCE DIMENSIONS

Combustible projections up to 75mm forward of the fixing plane of the fire to be a minimum of 125mm from the fireplace opening. Projections above 75mm forward of the fixing plane of the fire to be a minimum of 178mm from the fireplace opening. Non-combustible projections to be 75mm from the fireplace opening.

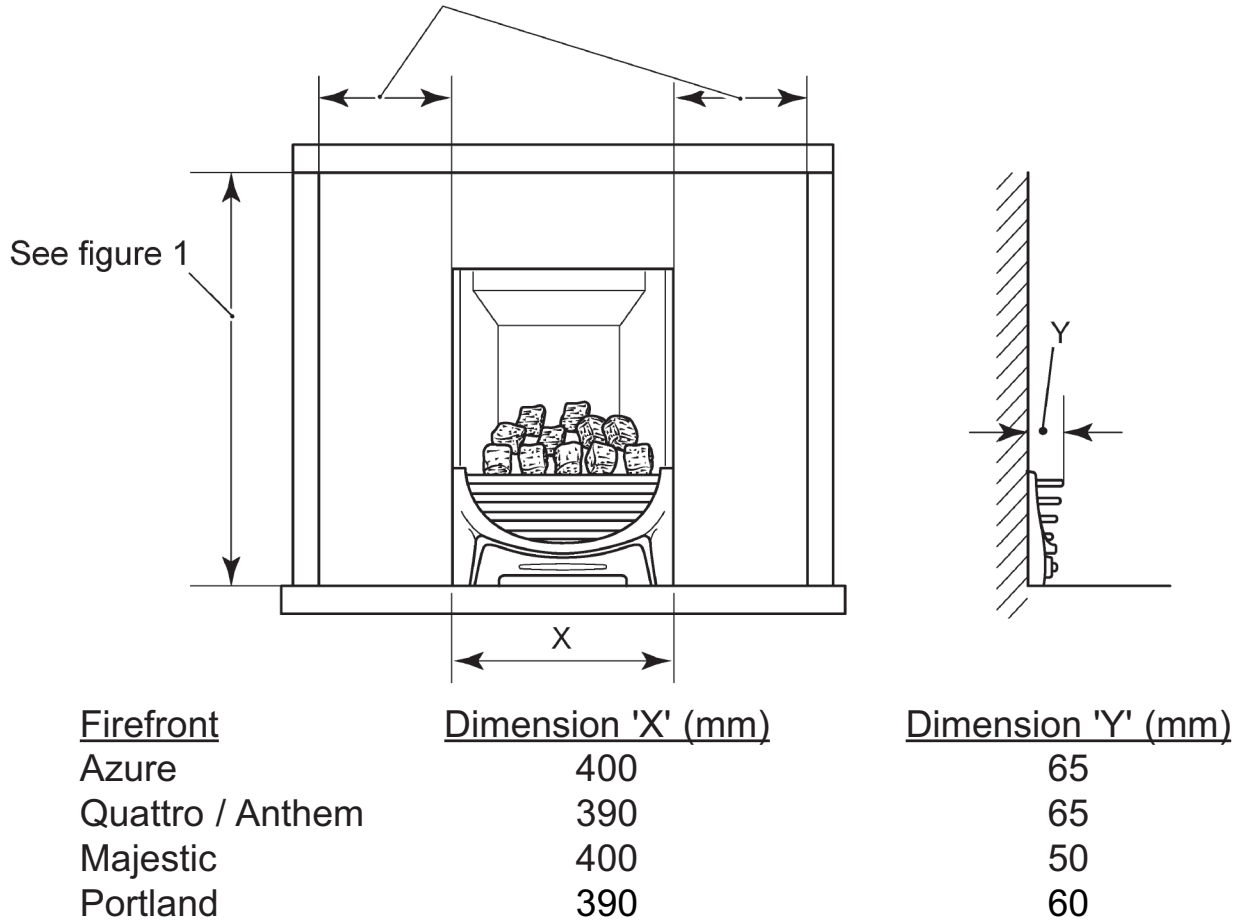

Figure 2. Appliance dimensions (Firefront may differ from that shown)

OWNER GUIDE

OPERATING THE FIRE

PLEASE NOTE

When operating your fire for the first time, some vapours may be given off which may cause a slight odour and could possibly set off any smoke alarms in the immediate vicinity. These vapours are quite normal with new appliances. They are totally harmless and will disappear after a few hours use.

The Oxysafe flame sensing & flue blockage safety system.

For your safety, this appliance is fitted with a flue blockage safety device that will shut down the appliance in the event of abnormal flue conditions. **This device is NOT a substitute for an independently mounted Carbon Monoxide detector.**

The device will also automatically shut off the gas supply to the fire if the pilot flame goes out due to lack of oxygen or for any other reason.

If this device starts to repeatedly shut off the gas, get expert advice.

This device incorporates a probe that senses that the heat from the pilot flame is correct. If this probe is cool, the device will prevent any gas flow unless the control knob is held in at the ignition position.

If, for any reason, the flames go out when the fire is hot or if the fire is turned off when hot, always **wait at least three minutes before attempting to relight.**

To light the fire.

Depress the control knob and slowly rotate it anticlockwise to the pilot ignition position. A 'click' will be heard as the integral piezo operates. A flame should appear at the pilot. Keep the control knob depressed and hold the pilot ignition position for ten seconds. When the control knob is released the pilot flame should remain lit. If a flame does not appear at the pilot then turn the control knob clockwise to the 'OFF' position and repeat the above.

When the pilot burner is operating properly, gradually turn the control knob anticlockwise to 'HIGH' position. (Depress the knob slightly to get past the pilot ignition position).

The main burner should now light. Depress the control knob slightly to release from the 'HIGH' position and turn back (clockwise) to 'LOW'. While turning, the burner flames should gradually become lower but remain alight. Depress the control knob slightly to release from the 'LOW' position and turn back (clockwise) to the Pilot ignition position. The main burner should extinguish but the pilot should remain alight. Depress the control knob slightly and turn back (clockwise)

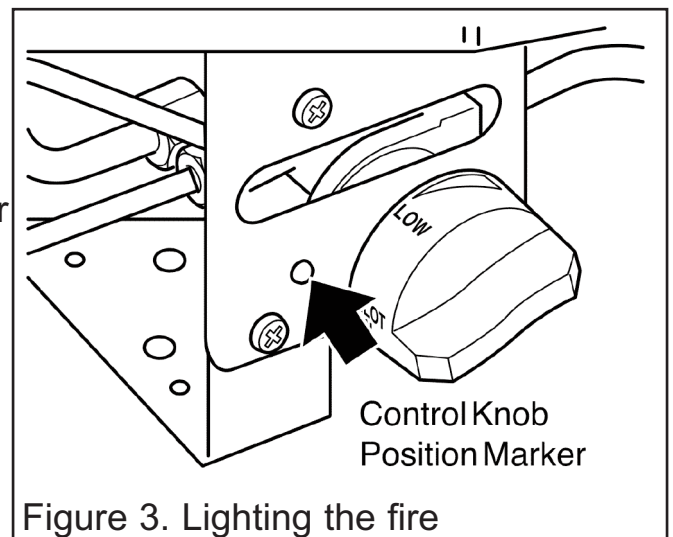

Figure 3. Lighting the fire

OWNER GUIDE

to turn OFF. This will extinguish the pilot.

While cooling, the ceramic fuel effect may make some crackling noises. This is quite normal.

- If the flames go out while setting the control, repeat the full lighting procedure.
- If the flames repeatedly go out have the fire serviced.
- Please note. When first turned on the flames will appear predominantly blue. The ceramic fuel effect will take time to warm up. Although some glow will be seen after approximately ten minutes, the full visual effect will only be apparent after a somewhat longer time.
- The appliance will operate to its maximum potential if the flue is primed during the first 20 – 30 minutes of operation. To do this, simply turn the control knob to its 'HIGH' setting. This will also burn off any carbon deposits that may have formed during previous operations.
- If operating the appliance for long periods it is beneficial occasionally to change the settings. This will also help to remove any carbon deposits that may form during operation.

Lighting with a taper.

See figure 4.

In the unlikely event of failure of the ignition spark, the pilot can be lit by a taper or long spill. Insert the taper or spill between the second and third left hand ceramic fuel effect pieces on the first row. Operate the control knob as described in the section headed 'To light the fire'.

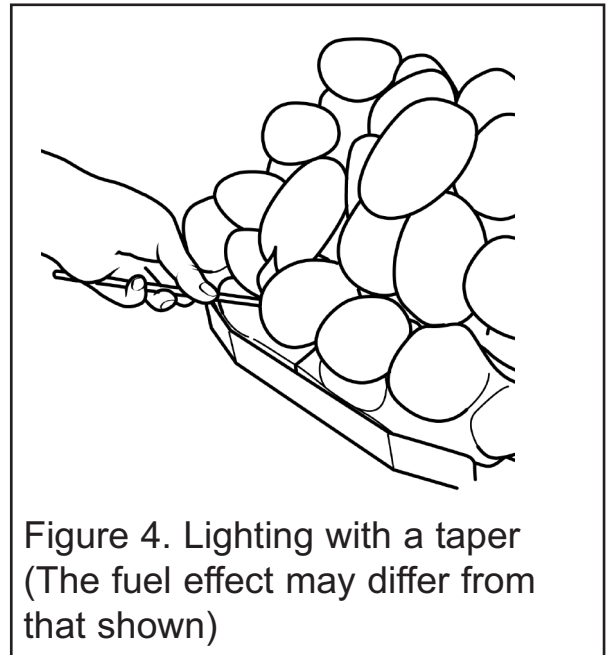

Figure 4. Lighting with a taper
(The fuel effect may differ from that shown)

OWNER GUIDE

CLEANING

Turn the fire off and allow it to cool completely before attempting any cleaning. Note that the fire will retain heat for some time after it has been turned off.

If large pieces of debris are found anywhere in the fireplace, have the chimney inspected before further use.

Metal parts.

Clean the metal parts with a slightly damp cloth and then dry. **Do not use abrasive cleaners, they could scratch the surface.**

Ceramic fuel effect .

This product uses fuel effect pieces containing Refractory Ceramic Fibres (RCF), which are man-made vitreous silicate fibres. Excessive exposure to this material may cause irritation to eyes, skin and respiratory tract. Consequently, it is important to take care when handling these articles to ensure that the release of dust is kept to a minimum.

- Light coatings of soot will usually be burnt off during the normal operation of the fire.
- Should any soot accumulation become excessive, the ceramic fuel effect pieces should be removed from the fire for cleaning.
- Cleaning should be carried out in a well-ventilated area or in the open air by gently brushing with the pieces held away from your face so that you avoid inhaling the dust.
- We do not recommend the use of a normal domestic vacuum cleaner that may blow dust back into the air.
- We suggest that you remove the ceramic fuel effect pieces in the reverse order to that shown in the installer and owner guide supplied with the ceramic fuel effect. This should have been placed inside or attached to this guide by the installer.

Burner.

Remove any deposits of soot or other foreign matter from the burner with a dry soft brush. Be careful not to brush any particles into the open slots. Remove any particles from the slots with a vacuum cleaner fitted with a soft brush attachment. **Do not poke wire, etc. into the slots in the burner.**

OWNER GUIDE

CERAMIC FUEL EFFECT REFITTING

The installer and owner guide for the ceramic fuel effect is separate from this guide. The installer may have attached it to this guide or placed it inside. It is important that the installer and owner guide for the ceramic fuel effect is followed correctly. If replacing the ceramic fuel effect, where a new guide is supplied, follow the installer and owner guide supplied with the replacement fuel effect. Keep the replacement installer and owner guide with this owner guide for future reference.

FITTING THE LOWER FIREFRONT

Decorative firefront.

For Quattro / Anthem firefronts please see section below.

To remove the firefront, remove the 'ash pan' (where applicable) and then lift the firefront clear.

To fit the firefront simply place the decorative firefront on the hearth and centralise to the appliance. Then fit the 'ash pan' (where applicable).

Quattro and Anthem firefront only

Note: Before removing the Quattro / Anthem firefront it is necessary to remove the ceramic fuel effect.

- Remove the fuel effect carefully and place aside. We recommend that the fuel effect is removed in the reverse order to that shown in the fitting sections.

- Remove the lower 'ash pan' (Where applicable).

- Lift the firefront clear of the burner.

- To fit the firefront, locate the firefront as in figure 5. The hooks should fit into the slots on the burner tray.

- The lower 'ash pan' should be located as in figure 6.

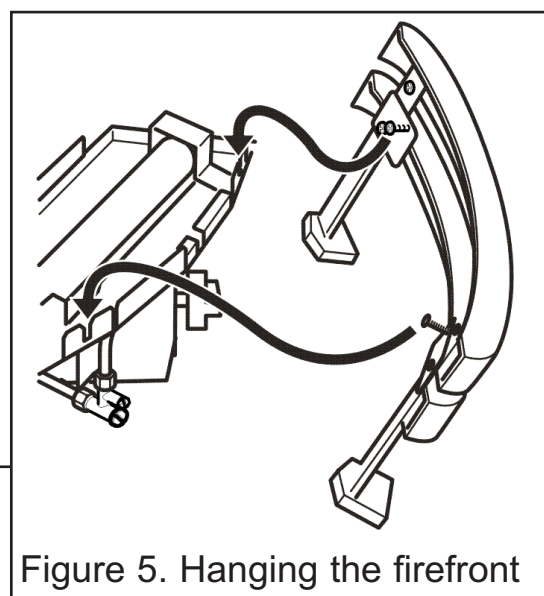

Figure 5. Hanging the firefront

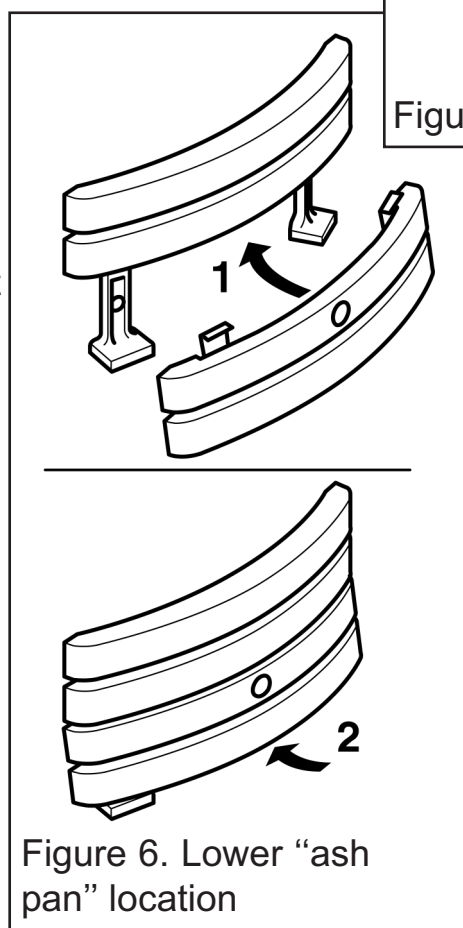

Figure 6. Lower "ash pan" location

OWNER GUIDE

MAINTENANCE

Regular maintenance.

In order to achieve and maintain high levels of personal safety and performance efficiency, it is essential that the opening at the back of the fire and the flue are kept clear of any form of obstruction. It is possible that deposits of mortar or soot could fall and accumulate causing the flue to be blocked or restricted and so preventing proper clearance of dangerous exhaust fumes.

In the United Kingdom it is the law that a landlord must have any gas appliance, flue and pipework which is situated in a tenant's premises checked for safety at least every twelve months by a competent person (A GAS SAFE REGISTER operative). We recommend that all gas appliances and their flues, wherever situated, are checked annually.

The service engineer must complete the relevant Service Record on **Page 42** after each service.

- **When fitting replacement parts it is important that only approved parts are used for maximum safety.**

WARRANTY AND SERVICE AND BENCHMARK

Standard Warranty Terms & Conditions

The warranty is for 12 months subject to contract.

In the United Kingdom servicing can be carried out either by a **Glen Dimplex UK** service operative or a **GAS SAFE REGISTER** operative. You must register your fire by calling our telephone registration line on **0344 879 3588**.

This product should be serviced annually to optimise its safety, efficiency and performance. The GAS SAFE REGISTER service engineer must complete the relevant Service Record on the Benchmark Checklist after each service.

It is also a requirement of the warranty that the fire has an annual service (every 12 months) in accordance with the installation and servicing instructions.



Benchmark Checklist/Service Record

Please ensure that the installer has fully completed the Benchmark Checklist on the inside back pages of the installation instructions supplied with the product and that you have signed it to say that you have received a full and clear explanation of its operation. The installer is legally required to complete a commissioning checklist as a means of complying with the appropriate Building Regulations (England and Wales). Installations carried out in England and Wales must be notified to Local Area Building Control either directly or through a Competent Persons Scheme. A Building Regulations Compliance Certificate will then be issued to the customer who should, on receipt, write the Notification Number on the Benchmark Checklist.

The filled in Benchmark Checklist/Service Record by the installer will be required in the event of any warranty (UK and Ireland installation).

After servicing, complete the relevant "Service Interval Record" section of the Benchmark Checklist located on the inside back pages of this document.

Our promise to you

If you experience a fault with your new fire, we aim to provide a safe and high quality repair service supported by our dedicated national network of highly skilled engineers. If your installer can't resolve the problem for you, we will do everything we can to get an engineer out to you as quickly as possible. Nothing in this warranty will affect your statutory rights.

What you need to do if you experience a problem with the operation of the fire:

- You should always contact your installer first, because the cause of the fault may not be related to the fire.
- If your installer confirms that the fault is with the fire and they can't repair it, our friendly customer service team is on hand to help.
- Simply call our UK Helpline on **0344 879 35 88** or from the Republic of Ireland call **01 842 8222** for any general advice that you may need.

When calling the **Helpline**, it would be helpful if you could have the following information to hand:-

1. Fire serial number and fascia code (Located on the information label - See figure 7 on page 43)*.
2. Date of installation*.
3. Your installer name and address details*.
4. Fire make and model number*.
5. Annual Service record details*
6. Proof of purchase (if you do not have the fire serial number)

***Note: details 1 – 5 should be recorded as part of the Benchmark Checklist / Service record at the end of this guide.**

OWNER GUIDE

What this warranty covers

What this warranty covers

Free of charge repair or replacement of components found to be of faulty manufacture.

Free of charge replacement of the complete unit providing the failure is related to a manufacturing fault that cannot be repaired or is uneconomic to repair.

What this warranty does not cover

Repairs to fires which haven't been installed and commissioned properly and as set out in the installation instructions.

Faults caused by inadequate supply of gas or electricity (where applicable).

Reimbursement of any third party repair or replacement costs that we haven't been told about or agreed with you in advance.

Compensation or consequential losses (e.g. loss of earnings, business losses, stress and inconvenience) arising from a production breakdown, including repair delays caused by factors outside our reasonable control.

OWNER GUIDE

GAS FIRE COMMISSIONING CHECKLIST

This Commissioning Checklist is to be completed in full by the competent person who commissioned the gas fire as a means of demonstrating compliance with the appropriate Building Regulations and then handed to the customer to keep for future reference.

Failure to install and commission according to the manufacturer's instructions and complete this Benchmark Commissioning Checklist will invalidate the warranty. This does not affect the customer's statutory rights.

Customer name:										Telephone number:									
Address:																			
Gas Fire make and model:																			
Gas Fire serial number:																			
Commissioned by (PRINT NAME):										Gas Safe register number:									
Company name:										Telephone number:									
Company address:																			
										Commissioning date:									
Building Regulations Notification Number (if applicable):																			
Site Requirements															Yes	N/A			
Was the chimney checked to ensure it only serves one flue/fire, has no obstructions and is continuous?																			
Has any debris at the base of the chimney been removed?																			
For brick chimney installations is there enough depth for 12 litres of debris, or precast flues 2 litres of debris? (see instructions for debris gap details)																			
Have damper and register plates been removed or locked in the fully open position ensuring correct size of flue is maintained?																			
If previously used for solid fuel has the chimney been thoroughly swept?																			
If the chimney is pre-cast has the inside of the flue been checked for extruded cement / sealant which must be removed?																			
Has the fire place been checked for under-floor air supply which must be sealed off?																			
Has the chimney been inspected prior to fitting the gas fire to ensure that it is in good condition?																			
Has the structure of the chimney been checked for leakage using a smoke pellet test? (See BS5440-1 for details).																			
Ventilation																			
Does the installation require any additional ventilation requirements as detailed in the manufacturer's instructions?																			
Hearth Requirements- where fitted																			
Is the hearth constructed from non-combustible material?																			
Is the hearth a minimum of 12mm thick with a minimum floor to top surface of 50mm?(BS5871) or as per manufacturer's instructions?																			
Is the hearth for open fronted fires a minimum of 760mm wide and has 300mm projecting from the fire opening (BS6871) or to manufacturer's instructions?																			
Mounting height (where applicable) has the fire been installed to the correct mounting height- as per manufacturer's instructions?																			
Firebox and Fuel Bed																			
Has the fuel bed, coals, pebbles etc. been fitted to manufacturer's instructions?																			
Gas Supply																			
Has an isolation tap/restrictor inlet elbow been fitted for servicing?																			
Has the gas supply been thoroughly purged prior to connection to remove any debris?																			
Has a gas tightness test been completed prior to breaking into the gas supply and following completion of installation?(IGEM/UP/1B)																			
Record burner gas pressure reading? If only the supply pressure is available a gas rate must be undertaken.(GSIUR REG26/9C)																			
Record dynamic inlet gas pressure (working pressure) reading (all gas appliances running)																			
Spillage test																			
Installation passes smoke match test with any extractor fans turned on (see manufacturer's instructions)																			
Installation																			
Has the gas fire been installed and commissioned in accordance with manufacturer's instructions?																			
Has the fire been installed with the correct clearance to combustible materials, as per manufacturer's instructions?																			
The operation of the appliance and controls have been demonstrated to the customer including battery replacement where applicable?																			
The manufacturer's literature, including Benchmark Checklist and Service record has been explained and left with the customer?																			
Has the appliance been registered with the Local Authority as detailed on the Gas Safe web site and is a legal requirement and forms part of the warranty?																			
Customer's Signature:										Commissioning Engineer's Signature:									
(To confirm satisfactory demonstration and receipt of manufacturer's literature)																			

*All installations in England and Wales must be notified to be Local Authority Building Control (LABC) either directly or through a Competent Persons Scheme. A Building Regulations Compliance Certificate will then be issued to the customer.



OWNER GUIDE

SERVICE RECORD

It is essential that your gas fire is serviced regularly and that the appropriate Service Interval Record is completed.

Service Provider

Before completing the appropriate Service Record below, please ensure you have carried out the service as described in the manufacturer's instructions. Always use the manufacturer's specified spare part when replacing controls.

SERVICE 01	Date:	SERVICE 02	Date:
Engineer name:		Engineer name:	
Company name:		Company name:	
Telephone No:		Telephone No:	
Gas safe register No:		Gas safe register No:	
Comments:		Comments:	
Signature		Signature	
SERVICE 03	Date:	SERVICE 04	Date:
Engineer name:		Engineer name:	
Company name:		Company name:	
Telephone No:		Telephone No:	
Gas safe register No:		Gas safe register No:	
Comments:		Comments:	
Signature		Signature	
SERVICE 05	Date:	SERVICE 06	Date:
Engineer name:		Engineer name:	
Company name:		Company name:	
Telephone No:		Telephone No:	
Gas safe register No:		Gas safe register No:	
Comments:		Comments:	
Signature		Signature	
SERVICE 07	Date:	SERVICE 08	Date:
Engineer name:		Engineer name:	
Company name:		Company name:	
Telephone No:		Telephone No:	
Gas safe register No:		Gas safe register No:	
Comments:		Comments:	
Signature		Signature	
SERVICE 09	Date:	SERVICE 10	Date:
Engineer name:		Engineer name:	
Company name:		Company name:	
Telephone No:		Telephone No:	
Gas safe register No:		Gas safe register No:	
Comments:		Comments:	
Signature		Signature	



OWNER GUIDE

Model

Serial number (Can be found on the information label - See figure 7)

A LABEL CONTAINING THE SERIAL NUMBER MAY HAVE BEEN PLACED INSIDE THIS BOX.

Fascia name (Block Capitals)

Fascia code - Can be found close to the information label (Block Capitals)

A LABEL CONTAINING THE FASCIA CODE MAY HAVE BEEN PLACED INSIDE THIS BOX.

Brand (Please tick)

Valor

Other.....

Date of Installation

D D M M Y Y

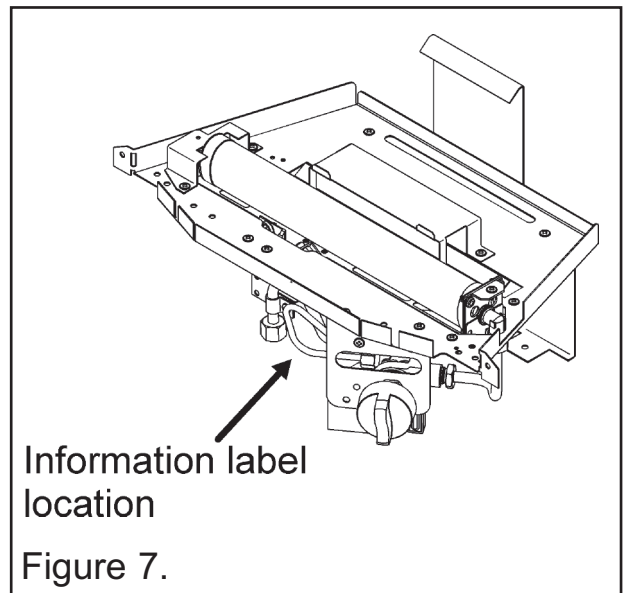

Recycling



At the end of this products useful life it should not be disposed of with household waste. Please recycle where facilities exist. Check with your Local Authority or retailer for recycling advice in your country.