

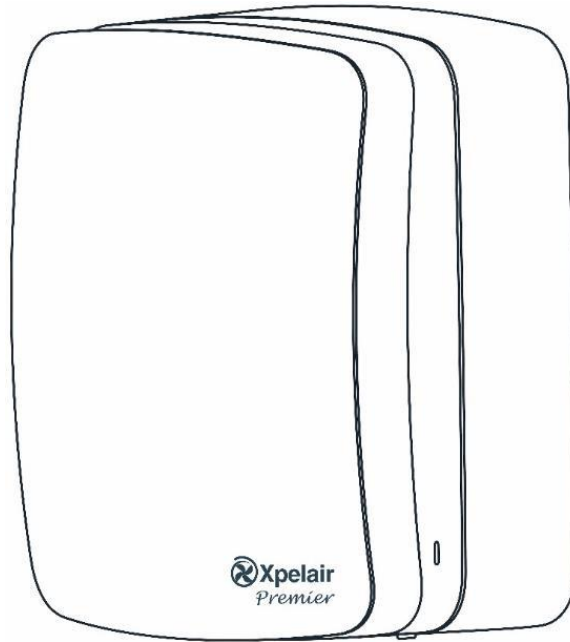

GB

# Instruction Manual Premier Fan LVCF20TX



Please read and  
keep these  
instructions

<p>Glen Dimplex UK LTD, trading as, <i>Glen Dimplex Heating &amp; Ventilation</i> Web: <a href="http://www.gdhv.co.uk">www.gdhv.co.uk</a> Millbrook House, Grange Drive, Hedge End, Southampton, SO30 2DF.</p>	
<p><b>Customer Service Tel: +44 [0]344 879 3588</b></p>	
<p><b><a href="http://www.xpelair.co.uk">www.xpelair.co.uk</a></b></p>	

© Glen Dimplex. All rights reserved. Material contained in this publication may not be reproduced in whole or in part, without prior permission in writing of Glen Dimplex

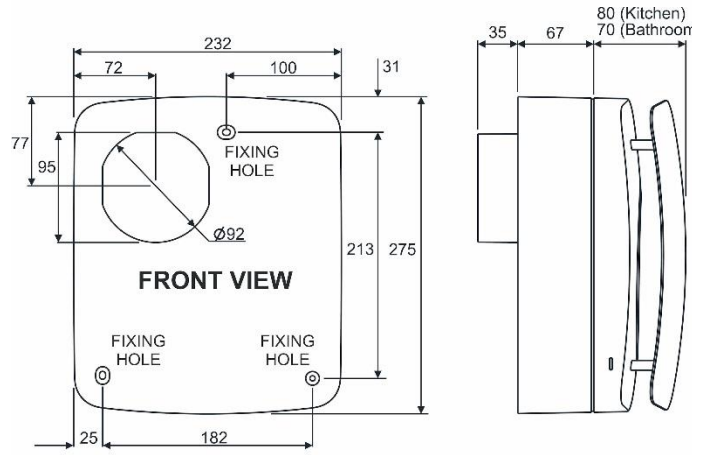
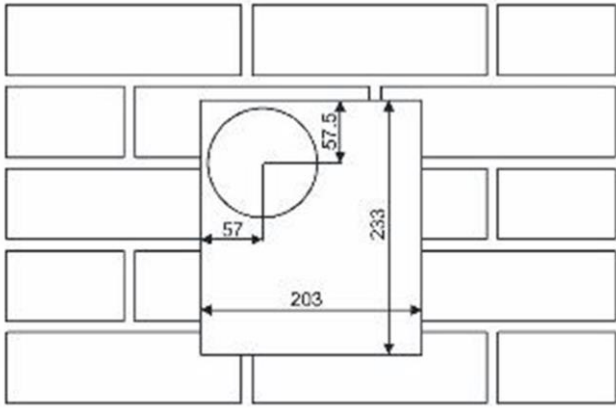
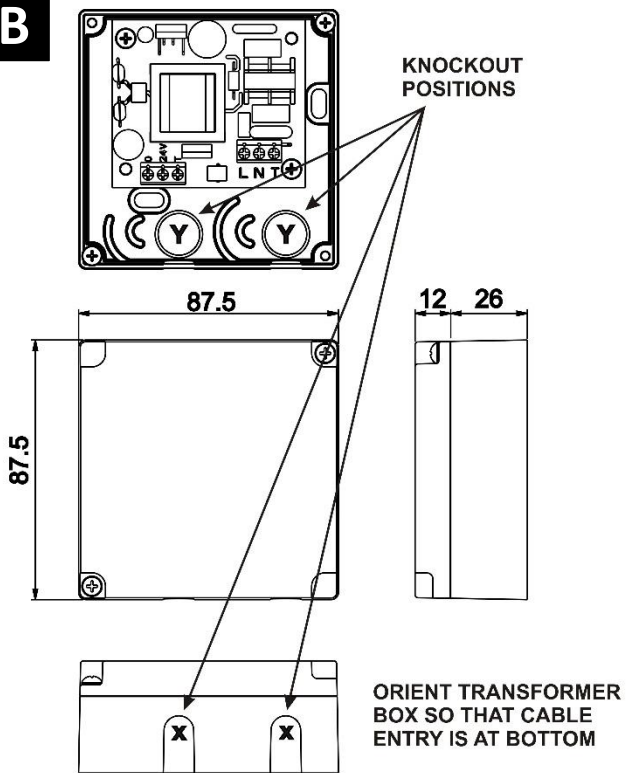
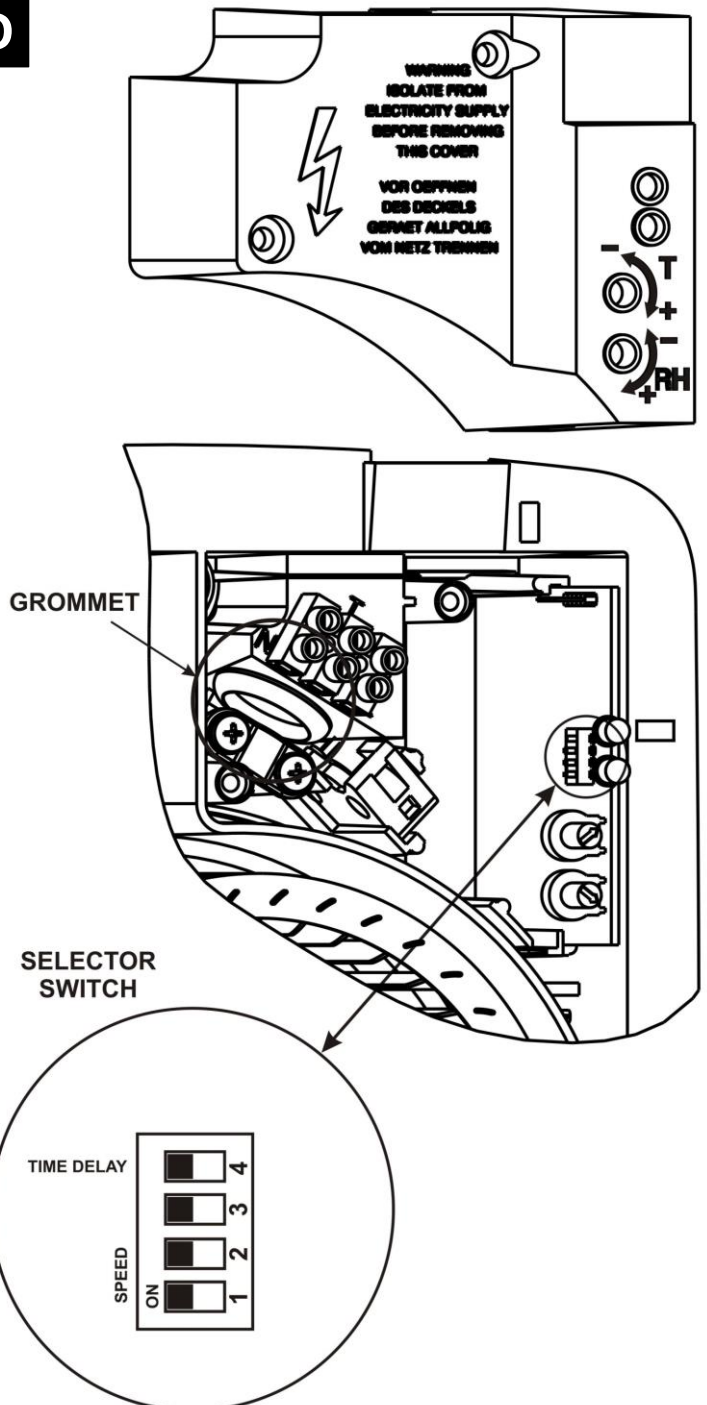
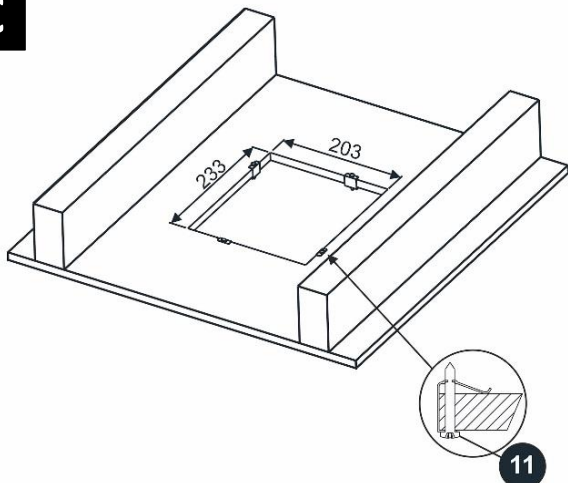
**A****B****D****C**

E

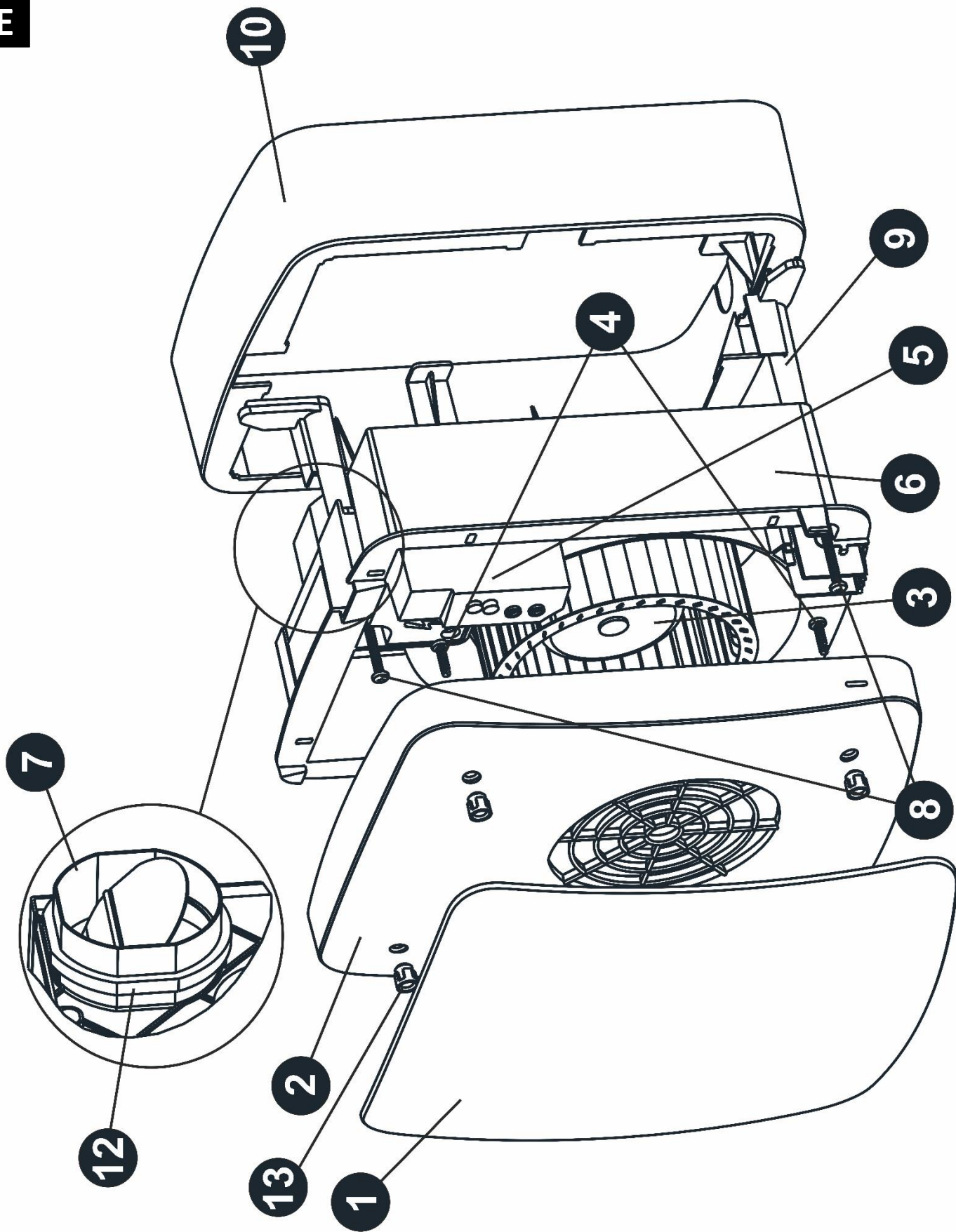

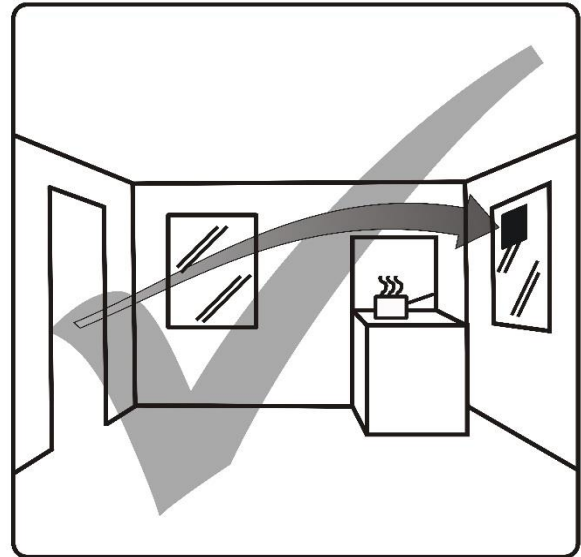
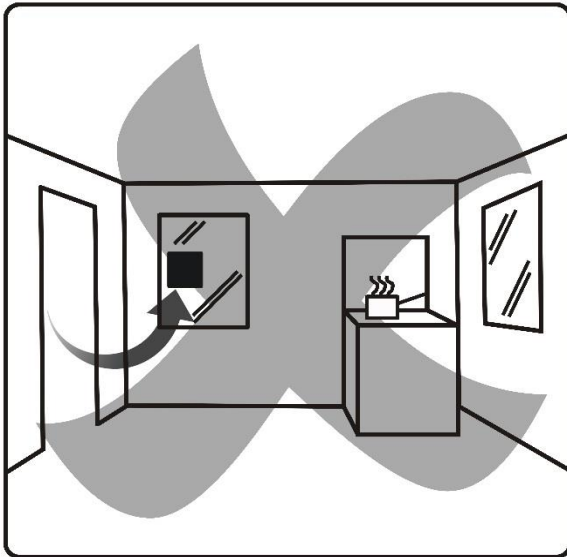
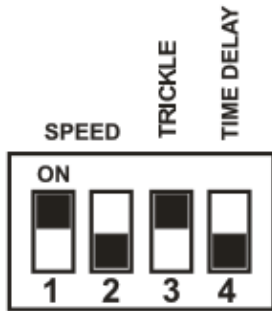
**F****G**

BATHROOM CONTINUOUS

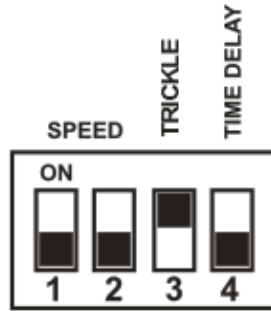

TOILET CONTINUOUS

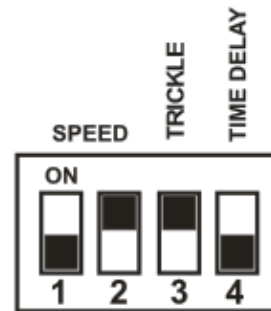

UTILITY CONTINUOUS

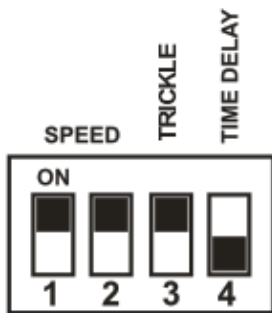

KITCHEN CONTINUOUS

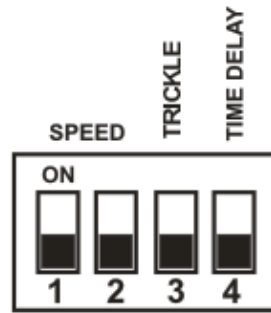

TOILET INTERMITTENT

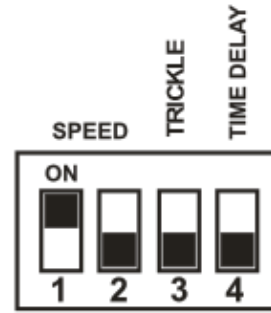

BATHROOM INTERMITTENT

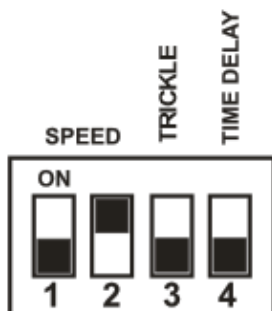

UTILITY INTERMITTENT

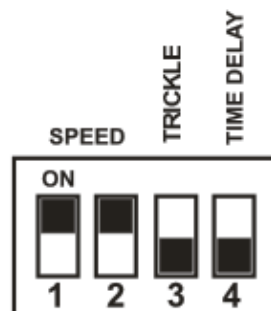

KITCHEN INTERMITTENT

**H**

Pictorial view inside transformer box, detailing terminal block positions

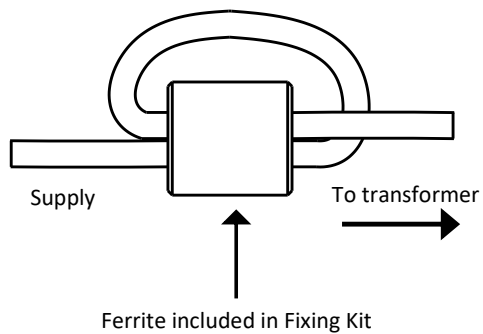
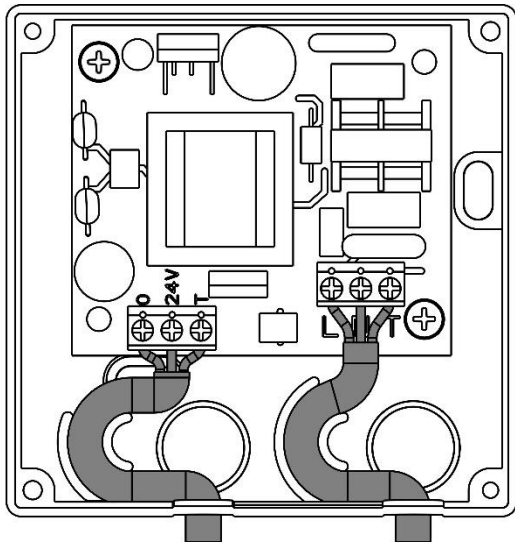

For fixed circuits the protective fuse for the appliance must not exceed 5A.

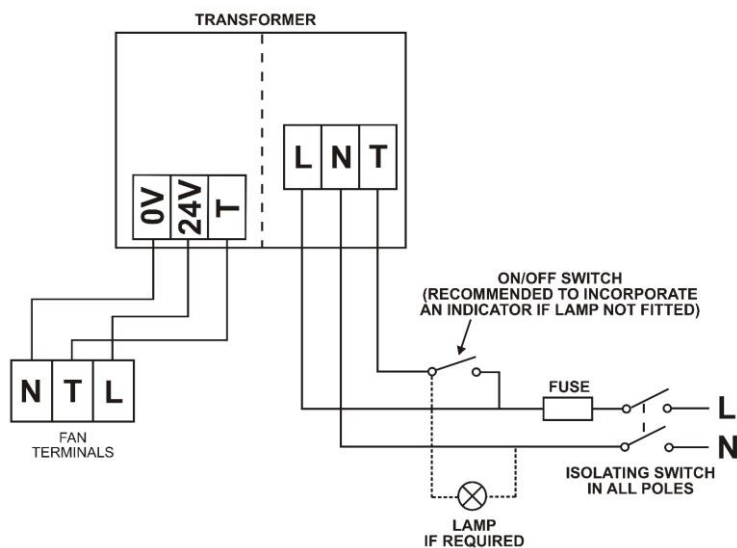
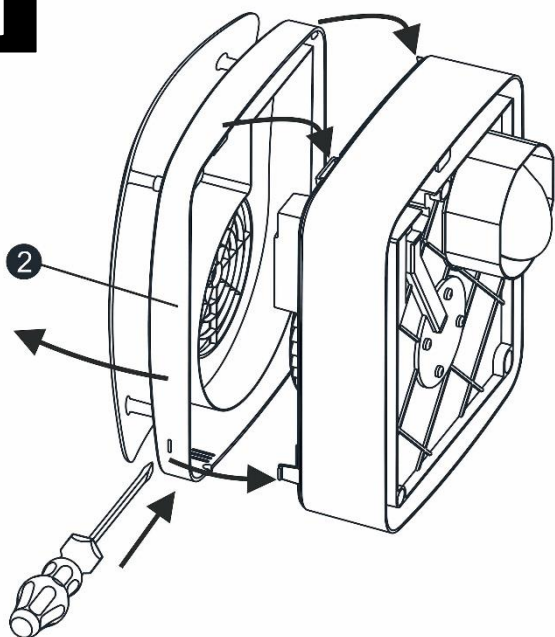
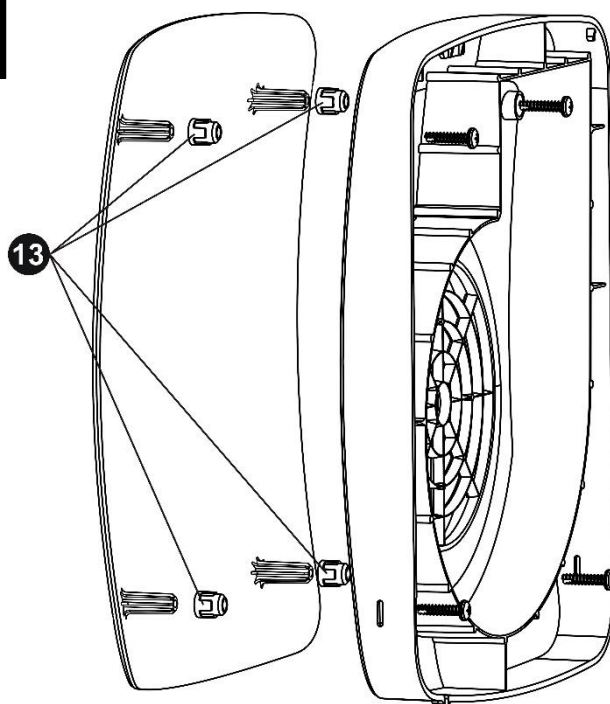
**I****J**



**THIS APPLIANCE CAN BE USED BY CHILDREN AGED FROM 8 YEARS AND ABOVE AND PERSONS WITH REDUCED PHYSICAL, SENSORY CAPABILITIES OR LACK OF EXPERIENCE AND KNOWLEDGE IF THEY HAVE BEEN GIVEN SUPERVISION OR INSTRUCTION CONCERNING THE USE OF THE APPLIANCE IN A SAFE WAY AND UNDERSTAND THE HAZARDS INVOLVED. CHILDREN SHALL NOT PLAY WITH THE APPLIANCE.**

**CLEANING AND MAINTENANCE OF THE APPLIANCE SHALL NOT BE MADE BY CHILDREN.**

**IMPORTANT**

1. READ **ALL** THESE INSTRUCTIONS & WARNINGS FULLY BEFORE COMMENCING INSTALLATION.
2. INSTALLATIONS AND WIRING MUST CONFORM TO CURRENT IET REGULATIONS (UK), LOCAL OR APPROPRIATE REGULATIONS (OTHER COUNTRIES). IT IS THE INSTALLER'S RESPONSIBILITY TO ENSURE THAT THE APPROPRIATE BUILDING CODES OF PRACTICE ARE ADHERED TO.
3. A QUALIFIED ELECTRICIAN MUST SUPERVISE ALL INSTALLATIONS.
4. THESE APPLIANCES ARE INTENDED FOR CONNECTION TO FIXED WIRING.
5. CHECK THAT THE ELECTRICAL RATING SHOWN ON THE TRANSFORMER MATCHES THE MAINS SUPPLY. **THE APPLIANCE IS DOUBLE INSULATED AND DOES NOT REQUIRE AN EARTH CONNECTION.**
6. SITE BOTH FAN AND TRANSFORMER AWAY FROM DIRECT SOURCES OF HEAT (I.E. GAS COOKERS OR EYE-LEVEL GRILLS). THE FAN MUST NOT BE MOUNTED WHERE AMBIENT TEMPERATURES ARE LIKELY TO EXCEED 50°C. THE TRANSFORMER MUST NOT MOUNTED WHERE AMBIENT TEMPERATURES ARE LIKELY TO EXCEED 40°C.
7. WHEN THE FAN IS INSTALLED IN A ROOM CONTAINING A FUEL BURNING APPLIANCE, THE INSTALLER MUST ENSURE THAT AIR REPLACEMENT IS ADEQUATE FOR BOTH THE FAN AND THE FUEL BURNING APPLIANCE.
8. ENSURE THAT ALL RELEVANT SAFETY PRECAUTIONS (CORRECT EYE PROTECTION AND PROTECTIVE CLOTHING ETC) ARE TAKEN WHEN INSTALLING, OPERATING AND MAINTAINING THIS FAN.
9. GENERAL GUIDANCE FOR SITING THE FAN SEE "FIG.F". ALWAYS SITE FAN AS HIGH AS POSSIBLE.
10. IF ANY SECTION OF THE DUCTWORK IS POSITIONED HIGHER THAN THE FAN A CONDENSATION TRAP (XCT100) MUST BE FITTED AS CLOSE AS POSSIBLE TO THE FAN.

*For speed and ease of Installation, your installation may require some of the Ancillaries indicated in "Ancillary Options"*

*If installing in a wall (surface mounting)*

1. Mark on the wall the centre of the duct hole **A**.
2. Use this centre to cut an opening through the wall 117mm diameter, with a slight fall to the exterior.
3. Fit the wall tube, not supplied, and mortar into place.

*If installing in a wall (flush mounting)*

1. Mark on the wall the centre of the duct hole **A**, and drill a pilot hole through both walls.
2. Use the centre to mark a rectangular hole for the inner wall using the dimensions **A**.
3. Cut the rectangular hole through the inner wall.
4. Go outside and cut a 117mm diameter hole in the outer wall using the small hole as the centre.
5. Measure the wall thickness.  
Cut the wall tube (WD100), not supplied, so that it is 70mm less than the wall thickness.

*If installing in a ceiling (surface mounting)*

This method requires a space above the ceiling, such as a loft or attic, to provide access for 100mm internal diameter ducting, or a minimum 70mm void using flat ducting.

1. Mark on the ceiling the centre of the duct hole **A**, avoiding ceiling joists and buried cables etc.
2. Cut a 117mm diameter hole using the marked centre.

*If installing in a ceiling (flush mounting)*

For 100mm diameter ducting:  
This method requires a space above the ceiling, such as a loft or attic, to provide access for 100mm internal diameter ducting.

1. Mark a rectangular hole using the dimensions **C**.
2. Cut the hole, avoiding ceiling joists and buried cables etc.

For flat ducting:

- This fan can be installed within a 140mm void with the circular spigot **7** (Fig. **E**).

*Preparing the fan for installation*

1. Remove the front cover **2** (Fig. **I**)

2. If the fan is required to run in a Kitchen Intermittent application, space the baffle away from the Front Cover using the spacers provided (See Fig. **J**)
3. Fit the foam tape **12** supplied around the circular spigot **7** (Fig. **E**).
4. Remove the electrical cover **5** (Fig. **E**).

**Setting the Fan Control Speed**

The fan speed should be set according to the application in which it is installed i.e. Toilet, Bathroom, Utility Room or Kitchen using the Selector Switch (Fig. **D**)

5. Use switches 1 and 2 on the Speed Selector Dipswitch as detailed in Fig. **G**. Please note that the fan is factory set to "Toilet Setting".

Switch Position	Size / Room Volume (m <sup>3</sup> )
1 – OFF, 2 – OFF	Toilet
1 – ON, 2 – OFF	Bathroom
1 – OFF, 2 – ON	Utility
1 – ON, 2 – ON	Kitchen

**Setting the Fan to Continuous or Intermittent Extraction**

The fan can be set to run in continuous or intermittent mode using the Selector Switch (Fig. **D**)

7. Use switch 3 on the Speed Selector Dipswitch as detailed in Fig. **G**. Please note that the fan is factory set to "OFF" (Intermittent) position.
8. Switch Position Setting
 

3 - OFF	Trickle extraction OFF
3 - ON	Trickle extraction ON

**Setting the time delay start**

9. The fan can be set so that there is a 2-minute delayed start to its operation when used with an external on/off switch. Use switch 4 on the Speed Selector Dipswitch as detailed in Fig. **G**. Please note that the fan is factory set to "OFF" Position.

Switch Position	Setting
4 - OFF	Time delay start OFF
4 - ON	Time delay start ON

**Mounting the Fan**

The fan must not be mounted where ambient temperatures are likely to exceed 50°C.

**Mounting the fan in a wall or ceiling (surface mounting)**

1. Place the ducting into the hole and align to the required position. If wall mounting, ensure that the ducting slopes down and away from the fan
2. Mark the positions of the three fixing holes **A** in Fan box **6** (Fig. **E**).
3. If wall mounting, drill three holes 5.5mm diameter for wall plugs (supplied). If ceiling mounting **C**, use appropriate fasteners (not supplied).
4. Slide the surround **10** over the fan box **6**.
5. Slit the cable grommet and insert into the cable grommet hole as shown in Fig. **D**. Pass the electrical cables into the fan box **6** through the cable grommet in the rear cable inlet hole and surround.  
**Ensure that cable grommet is in place and a tight fit.**
6. Offer the fan box **6** up to the wall or ceiling. Ensure the circular spigot **7** enters the ducting.
7. Fix the fan box **6** to the wall using screws **8** or to the ceiling using appropriate fasteners (not supplied).

**If mounting in a wall (flush mounting)**

The surround **10** is not required. Fit the ducting to the circular spigot **7**.

**If the hole size is as recommended:**

1. Assemble the three fan body clamps **9** to the fan box **6** using screws **8**.
2. Slit the cable grommet and insert the grommet into the cable grommet hole as shown in Fig. **D**. Pass the electrical cables into the fan box **6** through the cable inlet hole and cable grommet.  
**Ensure cable grommet is in place and a tight fit.**
3. Offer the fan box **6** up to the wall. Ensure the circular spigot **7** enters the ducting.
4. Tighten up the three screws **8** until the fan is clamped to the inner wall. The fan body clamps **9** will rotate to an automatic stop position. **DO NOT OVERTIGHTEN.**

**If the hole size is larger than recommended i.e. larger than the flange on the fan box **6** (Mostly relating to "retro-fit" installations):**

1. The fan body clamps ARE NOT suitable. Construct a wooden frame of INTERNAL dimensions 232 x 280mm. Depth should be at least 50mm. Fit the wooden frame into the internal wall and make good the hole.
2. Offer the fan box **6** up to the wall. Ensure the circular spigot **7** enters the ducting.
3. Screw the fan box **6** to the wooden frame using the slots in the flange (screws not supplied).

**If installing in a ceiling (flush mounting)**

1. The surround **10** is not required.

- Insert the fan box **6** into the hole and mark four positions using the slots in the flange **6**.
  - Remove the fan box **6** from ceiling and fit the four ceiling clips (supplied) over the edge of the hole, so that the clips align with the marks on the ceiling **6**.
  - Drill 4 pilot holes into the ceiling through the hole of each clip, ensuring not to damage the clip, and fit the clips ensuring correct alignment.
  - Fit the ducting to the circular spigot **7**.
  - Offer the fan box **6** up to the ceiling.
  - Slit the cable grommet and insert the grommet into the cable grommet hole as shown in Fig. **D**. Pass the electrical cable into the fan box **6** through the front cable inlet hole.
- Ensure cable grommet is in place and a tight fit.**
- Using the screws **11** (Fig. **C**), fix the fan box flange to the ceiling clips.

### Terminating the ducting

Fit the outer grille to the outer wall. For ceiling mounting, use appropriate ancillaries (not supplied).

### Mounting the transformer

The transformer **8** can be fixed directly to the wall. The transformer can be sited in a loft or in a convenient position on a wall (**not ceiling**). **The transformer must not be covered by loft insulation. For wall mounting the Transformer must be oriented as shown in **8** to fulfil ingress protection requirements.**

**The transformer must also not be mounted within 0.6m of a bath or shower cubicle, up to a height of 2.25m**

**The transformer must not be mounted where ambient temperatures are likely to exceed 40°C.**

The ferrite enclosed in the fixing kit must be fitted to the cable and looped around and back in as shown in Fig. **8**. The ferrite must be placed **before** the transformer. This is for EMC compliance.

### Fixing the transformer directly

- Remove the two screws securing the cover, remove the cover.
  - Position the transformer on the wall and mark the two fixing holes.
  - Drill and plug the two holes and fix the transformer.
- For loft mounting:**  
The transformer can be fixed to a wooden surface.
- For concealed wiring:**  
Use the round knockouts (Y).
- For fixed surface wiring:**  
Use the knockouts (X).

### Wire the fan

- Isolate the electricity supply and remove all fuses. The terminal block will accept cable up to 1.5mm<sup>2</sup>**
- A means for disconnection in all poles must be incorporated in the fixed wiring in accordance with the wiring regulations.
- Use suitably rated cable.
- Wire the fan as shown in **H** and use the cable clamp provided to secure the cable.
- See section on "User adjustments" if you wish to use settings other than those that have been factory set.
- Replace the terminal cover **5** and fasten the retaining screws.
- Refit the front cover **2** (Fig. **C**).
- Connect the cable from the isolating switch to electrical supply wiring, and re-check installation.
- Refit fuses before turning on electricity supply.
- For fixed wiring circuits, the protective fuse for the appliance must not exceed 5A

### For Australia Only

Permanently connected to the supply and a remote switch controls operation. They should be directly wired to the supply through an approved 10A wall mounted surface switch with at least 3mm clearance between contacts.

### Wire the transformer

- Wire the transformer as shown in **H**.
- Ensure all connections are tight.
- Route cable through retaining labyrinth.
- Replace the transformer cover with the two screws.
- Switch off the mains electrical supply and remove fuses.**
- Connect the cable from the isolating switch to the electrical supply wiring.
- For fixed wiring circuits the protective fuse for the appliance must not exceed 5A.

### User adjustments

**Before making any adjustments, isolate the fan completely from the mains supply.**

- Remove the front cover and replace after adjustment (Fig. **I**)
- The timer over-run period can be adjusted between approximately 30 seconds and 30 minutes. Use an electrician's screwdriver and turn screw "T" (Fig. **D**), clockwise to increase time, anti-clockwise to decrease. The default timer setting is 15 minutes.
- The humidity setting is adjustable between approximately 50% and 90% relative humidity. Use an electrician's screwdriver, turn screw "RH" (Fig. **D**), clockwise to increase the relative humidity setting and anti-clockwise to decrease. The default relative humidity setting is 75%. (Note: the fan is more sensitive at 50% RH than at 90%).

### Using the fan

#### Time delay start feature on or off

This is set by the installer to provide a 2-minute time delay start when the fan is switched on using a separate on/off switch.

### Intermittent Mode

#### Switched Operation

Fan operates at intermittent speeds as determined by the speed selector switch when switched on via a separate on/off switch. Top "Light I" is lit when the separate on/off switch is switched on. When switched off, the fan continues to operate for the adjustable timer over-run period. After the over-run period, the fan will continue to operate if the humidity level is above that set by adjusting screw "RH"

#### Condensation Operation

The fan operates at intermittent speeds as determined by the speed selector switch when the relative humidity exceeds the set level and turns off when the humidity drops (Both lights off).

#### Boost Operation

Pull Cord sequence:  
Pull Cord once, fan operates at intermittent speeds as determined by the speed selector switch (bottom "light II" is on - High intensity).  
Pull cord again, fan switches off.  
The fan will continue to operate if the humidity level is above that set by adjusting screw "RH" (both lights off)

### Continuous Mode

This is set by the installer to provide continuous background extraction at a speed determined by the speed selector switch.

#### Switched Operation

The fan will boost from the continuous speed setting to a 'low boost' when a separate on/off switch is operated. Top "Light I" is lit when the separate on/off switch is switched on. When switched off, the fan continues to operate for the adjustable timer over-run period. After the over-run period, the fan will return to the continuous speed setting unless the condensation operation is active (both lights off).

#### Condensation Operation

The fan will boost from the continuous speed (or low boost speed if active) setting to a 'high boost' when the relative humidity exceeds the set level and returns to the continuous speed setting when the humidity drops (Both lights off).

#### Boost Operation

Pull Cord sequence:  
Pull Cord once, the fan will boost from the continuous speed setting to a 'low boost' (bottom "light II" is on - Low intensity).  
Pull cord again, the fan will boost from the 'low boost' speed to the 'high boost' (bottom "light II" is on - High intensity).  
Pull cord again, the fan will return to the continuous speed setting unless the Condensation operation is active (both lights off).

### Hour run meter

The fan incorporates an hour run meter that allows the installer to measure the actual running time of the fan after installation. The meter records continuous power supply on time and displays this via the top "light I" which flashes to indicate the total number of hours the supply has been on, when powered up.

**LED flash sequence to indicate hour run:**

- LED off for 2 seconds to indicate the start of the count, then:
- 0 to 2000 hours: LED on for 1 short flash (0.5s on/0.5s off)
- 2000 to 3000 hours: LED on for 2 short flashes
- 3000 to 4000 hours: LED on for 3 short flashes
- 4000 to 5000 hours: LED on for 4 short flashes
- 5000 to 6000 hours: LED on for 5 short flashes
- 6000 to 7000 hours: LED on for 6 short flashes
- 7000 to 8000 hours: LED on for 7 short flashes
- 8000 to 9000 hours: LED on for 8 short flashes
- 9000 to 10000 hours: LED on for 9 short flashes
- Each 10000 hours is indicated by 1 long flash (2s on/0.5s off)

#### Examples:

542 hours total on time:  
(2s off), (0.5s on/0.5s off).

1921 hours total on time:  
(2s off), (0.5s on/0.5s off).

2780 hours total on time:  
(2s off), (0.5s on/0.5s off), (0.5s on/0.5s off).

24355 hours total on time:  
(2s off), (2s on/0.5s off), (0.5s on/0.5s off), (0.5s on/0.5s off), (0.5s on/0.5s off), (0.5s on/0.5s off).

### Cleaning

- Before cleaning, isolate the fan completely from the mains supply**
- Only clean the external surface of the fan, using a damp lint free cloth.
- Do not use strong detergents, solvents or chemical cleaners
- Allow fan to dry thoroughly before use.
- Apart from cleaning, no other maintenance is required.

### Key

See Diagram **E**

- Baffle Plate
- Front Cover
- Motor/Impeller
- Baffle Fixing Screws
- Terminal Cover
- Fan Box
- Circular Spigot
- Clamp screws and wall plugs - 3 off
- Fan Body Clamps - 3 off
- Surround
- Ceiling Screws 25mm long 4 off (Diagram **B**)
- Foam Tape
- Baffle Spacers - 4 off

**PLEASE LEAVE THIS LEAFLET WITH THE FAN FOR THE BENEFIT OF THE USER**

### Ancillary Options

For speed and ease of Installation, your installation may require some of the Ancillaries listed below:

<b>WD100</b>	Wall Duct
<b>CFWG100</b>	Wall Grille
<b>XCT100</b>	Condensation Trap
<b>DGW/B</b>	Air Replacement Door Grille
<b>SP100</b>	Spigot Plate
<b>XAA</b>	Air Brick Adaptor
<b>VC10</b>	Vent Cowl
<b>WT10</b>	Termination Ducting Kit
<b>XF/FM</b>	Flat Ducting (Metal 230x25 / Plastic 234x29)
<b>VK10</b>	Wall Vent Kit
<b>KHWG</b>	Wall Grille (Black)
<b>FD100</b>	Flexible Ducting
<b>WDC5</b>	Worm Drive Clips
<b>XCMK</b>	Ceiling Mounting Kit
<b>XBP</b>	In-Line Back Draught Shutter
<b>EFT</b>	Easy Fit Termination Kit
<b>PDXGF</b>	Grease Filter

### Spare Parts

For spare parts, please contact +44 [0]344 879 3588. Please have details of your model to hand.

<b>300001473</b>	Fixing Kit (LVCF20TX)
<b>X-SP02/70003/0</b>	Circular Spigot (Entire Range)
<b>X-SP03/70036/0</b>	Motor c/w Impellor (Entire Range)
<b>X-SP01/100098/0</b>	PCB Assembly (LVCF20TX)
<b>X-SP04/70043/0</b>	Front Cover c/w Baffle (LVCF20TX)
<b>X-SP01/100092/0</b>	Surround Moulding (Entire Range)
<b>X-SP03/70060/0</b>	Pull-Cord Assembly (Entire Range)
<b>X-SP04/70044/0</b>	Transformer (LVCF20TX)

## Warranty

### What does an Xpelair Warranty cover?

Xpelair products deliver reliable service for normal, household use in domestic settings. All Xpelair products are individually tested before leaving the factory.

If you are a consumer and you experience a problem with your Xpelair product, which is found to be defective due to faulty materials or workmanship within the Warranty Period, this Xpelair Warranty will cover repair or - at the discretion of Xpelair - replacement with a functionally equivalent Xpelair product.

The Xpelair Warranty Period is two calendar years with five years on the motor only, from the date of purchase of your Xpelair product, or the date of delivery of the product, if later. The Xpelair Warranty is conditional upon you providing the original purchase receipt as proof of purchase. Please therefore retain your receipt as proof of purchase.

If you do experience a problem with your Xpelair product, please call the Helpline on **+44 [0]344 879 3588** or at the address below.

We will need details of your Xpelair product, and a description of the fault which has occurred. Once we receive your information and proof of purchase, we will contact you to make the necessary arrangements.

Customers outside UK - see international below.

If your Xpelair product is not covered by this Xpelair Warranty, there may be a charge to repair your product. However, we will contact you for agreement to any charges before any chargeable service is carried out.

### What is not covered by an Xpelair Warranty?

The Xpelair Warranty does not cover any of the following:

- Any fault or damage to your Xpelair product due to faulty materials or workmanship occurring outside the Warranty Period.
- Any fault or damage occurring to any pre-owned Xpelair product or to any other equipment or property.
- Accidental damage to your Xpelair product or damage to your Xpelair product from external sources (for example, transit, weather, electrical outages or power surges).
- Fault or damage to your Xpelair product which is:
  - Not due to faulty materials or workmanship or which is due to circumstances outside Xpelair's control.
  - Caused by use of your Xpelair product for anything other than normal domestic household purposes in the country where it was purchased.
- Caused by any misuse, abuse or negligent use of the Xpelair product, including but not limited to any failure to use it in accordance with the Operating Instructions supplied with the product.
- Caused by any failure to assemble, install, clean and maintain your Xpelair product in accordance with the Operating Instructions supplied with the product unless this was carried out by Xpelair or its authorised dealers.
- Caused by repairs or alterations to your Xpelair product not carried out by Xpelair service personnel or its authorised dealer(s).
- Caused by use of any consumables or spare parts for your Xpelair product which are not Xpelair specified.

### Terms and Conditions

- The Xpelair Warranty is valid for Xpelair from the date of purchase of your Xpelair product from a recognised retailer in the country of purchase and use, or the date of delivery of the product if later, always provided the original receipt has been retained and is produced as proof of purchase.
- You must provide to Xpelair or its authorised agents on request the original receipt as proof of purchase and - if required by Xpelair - proof of delivery. If you are unable to provide this documentation, you will be required to pay for any repair work required.
- Any repair work under the Xpelair Warranty will be carried out by Xpelair or its authorised dealer(s) and any parts that are replaced will become the property of Xpelair. Any repairs performed under the Xpelair Warranty will not extend the Warranty Period.
- Any replacement of your Xpelair product by Xpelair during the Warranty Period will start the Warranty Period afresh from the date of delivery of the replacement Xpelair product to you.
- The Xpelair Warranty does not entitle you to recovery of any indirect or consequential loss or damage including but not limited to loss or damage to any other property.
- The Xpelair Warranty is in addition to your statutory rights as a consumer and your statutory rights are not affected by this Xpelair Warranty.

### Contact Xpelair

If you have any questions about what the Xpelair Warranty covers and does not cover or how to claim under the Xpelair Warranty, please contact us using the information below.

#### Contact details

Millbrook House, Grange Drive, Hedge End, Southampton, SO30 2DF

Telephone: +44 (0) 344 879 3588

Email: [customer.services@glendimplex.com](mailto:customer.services@glendimplex.com)

<http://www.xpelair.co.uk>

#### International.

- Guarantee: Contact your local distributor or Xpelair direct for details.
- Technical Advice and Service: Contact your local Xpelair distributor.

Xpelair: A brand of the GDC Group Limited, trading as Glen Dimplex Heating & Ventilation

© Glen Dimplex. All rights reserved. Material contained in this publication may not be reproduced in whole or in part, without prior permission in writing of Glen Dimplex

### Important



For electrical products sold within the European Community. At the end of the electrical products useful life it should not be disposed of with household waste. Please recycle where facilities exist. Check with a Local Authority or retailer for recycling advice in your country. Batteries should be disposed of or recycled in accordance with WEEE Directive 2012/19/EU. Packaging should be recycled where possible.



FM02118 ISO 9001: 2000

