



INSTALLER AND OWNER GUIDE

Please keep me in a safe place for future use.

I N S P I R E

COLLECTION

Inspire Gas Stove

Model's; L and M



Fitted with 401FS or 401RC LUMINAIRE

Inset live fuel effect gas fire with LED fuel bed.

We trust that this guide gives sufficient details to enable this appliance to be installed, operated and maintained satisfactorily. However, if further information is required, our **Valor Technical Helpline** will be pleased to help.

Telephone **0844 879 35 88** (National call rates apply in the United Kingdom).

In the Republic of Ireland Telephone **01 842 8222**.



THIS APPLIANCE IS FOR USE WITH NATURAL GAS (G20).

THIS APPLIANCE IS SUITABLE ONLY FOR INSTALLATION IN THE UNITED KINGDOM (GB) AND THE REPUBLIC OF IRELAND (IE).

© GDC Group Ltd.

All rights reserved. No part of this publication may be reproduced in any material form (including photocopying), stored in any medium by electronic means (including in any retrieval system or database) or transmitted, in any form or by any means, whether electronic, mechanical, recording or otherwise, without the prior written permission of the copyright owner.

Applications for the copyright owner's permission to reproduce any part of this publication should be made, giving details of the proposed use, to the following address: The Marketing Communications Manager, GDC Group Ltd, Millbrook House, Grange Dive, Hedge End, Southampton, SO30 2DF.

Warning: Any person who does any unauthorised act in relation to a copyright work may be liable to criminal prosecution and civil claims for damages.

Because our policy is one of constant development and improvement, details may vary slightly from those given in this publication

Safety First.

Valor fires are CE Approved and designed to meet the appropriate British Standards and Safety Marks.



Quality and Excellence.

All Valor fires are manufactured to the highest standards of quality and excellence and are manufactured under a BS EN ISO 9001 quality system accepted by the British Standards Institute.



The Highest Standards

Valor is a member of the Benchmark scheme and HHIC (Heating and Hot water Industry Council) that work to ensure high standards of safety, quality and performance.



Careful Installation

This gas fire must be installed by a competent GAS SAFE REGISTER operative in accordance with this installer guide.



INSTALLER GUIDE

FOR OWNER GUIDE SEE PAGES 39 TO 59

INSTALLER GUIDE

CONTENTS

<u>Section</u>	<u>Page</u>
INSTALLER GUIDE	4 - 38
OWNER GUIDE	39 - 59
1. APPLIANCE & CLEARANCE DIMENSIONS	8
2. SAFETY (GAS & ELECTRICAL)	9 - 10
3. THE BENCHMARKING SCHEME	11
4. APPLIANCE DATA, EFFICIENCY AND NO_x	12
4.1 General information.	13
4.2 Efficiency.	13
4.3 NO _x	13
5. GENERAL INSTALLATION REQUIREMENTS	14
5.1 Regulations, Standards and Law.	14
5.2 The Hearth	14
5.3 Clearances	14
5.4 Flue / Chimney	15
5.5 Ventilation requirements.	15
5.6 Location	15
5.7 The Atmosphere sensing device (ASD).	15
5.8 Fireguard requirements.	16
5.9 Use of extraction fan.	16
5.10 Clearance to flammable materials	16
5.11 Leveling the stove	16
5.12 Securing the stove	16
6. PACK CONTENTS	17 - 18
7. GAS SUPPLY CONNECTION	19
8. PREPARING APPLIANCE FOR INSTALLATION	19
9. IGNITION CHECK	20
9.1 Fitting slider handle to control cam (FS)	20
9.2 Fitting the battery into spark ignition generator (FS)	21
9.3 Checking the ignition operation	21
9.4 Fitting batteries into remote control handset (RC)	22
9.5 Fitting batteries into the valve (RC)	22
9.6 Setting the handset and receiver relationship (RC)	22 - 23
9.7 Factory reset of remote handset (RC)	23
9.8 Checking the ignition operation (RC)	23
9.9 Error codes (RC)	23

Continued on next page

INSTALLER GUIDE

CONTENTS (Continued)

<u>Section</u>	<u>Page</u>
10. LED CHECK	24
10.1 Fitting the transformers male DC jack connector into convection box	24
10.2 Connecting the male and female DC jack into the LED circuit	24
10.3 Checking the LED operation	24
11. FITTING THE WALL LINERS	25
11.1 Fitting the rear wall liner	25
11.2 Fitting the Glass liners spacer support.	25
11.3 Fitting the side wall liners.	25
12. BURNER AND SUPPLY PIPE INSTALLATION	26
12.1 Burner installation.	26
12.2 Supply pipe installation.	26
12.3 Burner checks - FS model	26
- 12.3.1 Lighting the fire	27
- 12.3.2 Adjusting flame height	27
- 12.3.3 Turning off	27
12.4 LED fuel effect checks.	27
- 12.4.1 Lighting the LED fuel effect	27
- 12.4.3 Turning off	27
12.5 Burner checks - RC model	28
- 12.5.1 Lighting the fire	28
- 12.5.2 Adjusting flame height	28
- 12.5.3 Turning off	28
12.6 Check inlet pressure.	29
13. REASSEMBLE OF FIRE & LOG SET LAYOUT	29- 31
13.1 Fitting the burner unit into convector box	29
13.2 Fitting the top tray onto the burner unit	29
13.3 Install the log set	29
- 13.3.1 Placement of the 4 small logs	29
- 13.3.2 Placement of Clear Glass Pebbles	30
- 13.3.3 Placement of Grey Chips and Natural vermiculite flakes	30
- 13.3.4 Placement of the 3 large logs	31
13.4 Fitting the top tray onto the burner unit	31
13.5 Install the log set	31
14. FULL OPERATING CHECKS	32
14.1 Check the burner operation.	32
14.2 Check for spillage.	32
14.3 Flame supervision and spillage monitoring system.	32 - 33

Continued on next page

INSTALLER GUIDE

CONTENTS (Continued)

<u>Section</u>	<u>Page</u>
15. FINAL REVIEW	33 - 34
16. SERVICING & PARTS REPLACEMENT	34
16.1 To remove the visual baffle.	34
16.2 To remove the window door panel.	34
16.3 To remove the fuel effect	34
16.4 To remove the top tray.	34
16.5 To remove the burner assembly	34
16.6 To access and remove the Inspection panel	35
16.7 To remove the wall liners	35
16.8 To remove the burner tubes (a) or pilot unit (b).	36 - 37
16.9 To remove the Gas valve LED On/Off switch or Ignition unit	37
16.10 To remove the TESC gas valve, LED On/Off switch or Manifold	37 - 38
16.11 To replace the burner injectors (s).	38
16.12 To remove the LED strip or LED controller PCB.	38

INSTALLER GUIDE

1. APPLIANCE DIMENSIONS

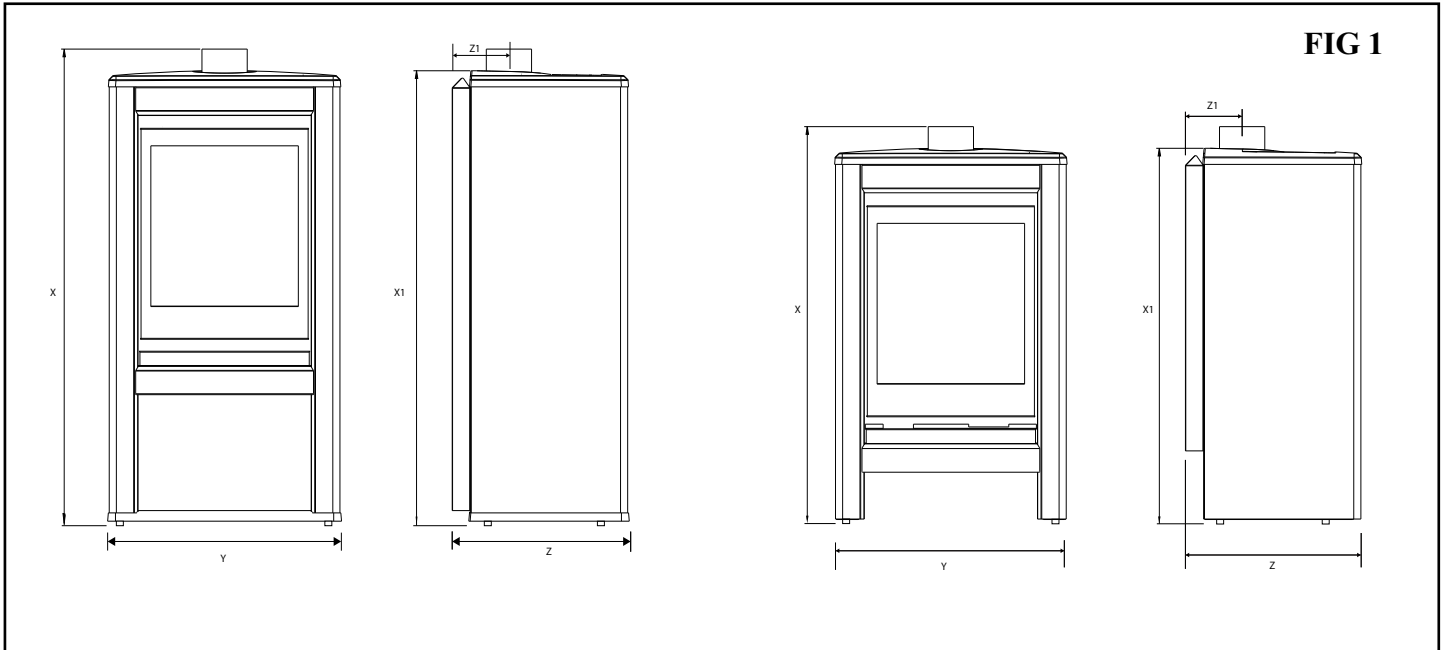

Product Dimension	L	M
X	1035 mm	863 mm
Y	525 mm	525 mm
Z	397 mm	397 mm
X1	988 mm	816 mm
Z1	127 mm	127 mm

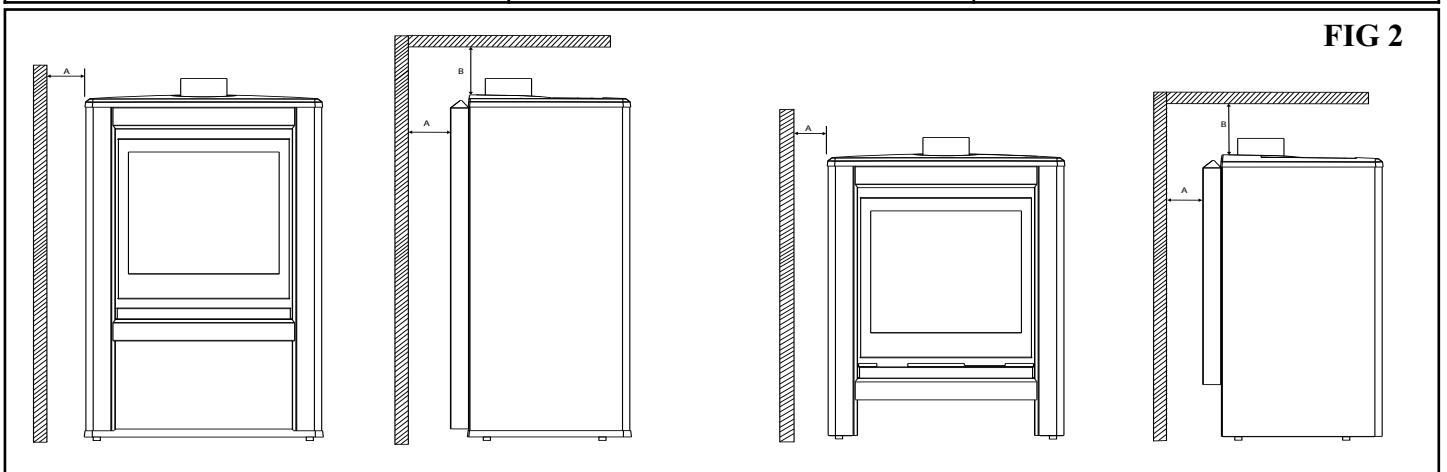

Clearance Dimensions	L & M	L & M
	A (Sides)	B (Shelf)
Minimum to Combustible Material	100 mm	-
Minimum to Combustible Shelf	-	300 mm
Minimum to Non-Combustible Material	50 mm	-
Minimum to Non-Combustible Shelf	-	100 mm

Installer

Before continuing any further with the installation of this appliance please read the following guide to manual handling.

- The lifting weight of this appliance (kg) is approx as below:

<u>Model</u>		<u>Weight</u>
Inspire Stove Model L	inc 401 engine*	40 Kg
Inspire Stove Model M	inc 401 engine*	51 Kg

**excludes liner set & packaging.*

These appliances are heavy. We therefore recommend that two person's should be sufficient to lift the fire. If fitting or moving the fire alone we recommend the use of suitable lifting apparatus.

- When lifting always keep your back straight. Bend your legs and not your back.
 - Avoid twisting at the waist. It is better to reposition your feet.
 - Avoid upper body/top heavy bending. Do not lean forward or sideways whilst handling the fire.
 - Always grip with the palm of the hand. Do not use the tips of fingers for support.
 - Always keep the stove as close to the body as possible. This will minimise the cantilever action.
 - Use gloves to provide additional grip.
 - Always use assistance if required.
- This product uses log fuel effect pieces, burner compartment walls and ceramic pebbles containing Refractory Ceramic Fibres (RCF), which are man-made vitreous silicate fibres. Excessive exposure to these materials may cause irritation to eyes, skin and respiratory tract. Consequently, it is important to take care when handling these articles to ensure that the release of dust is kept to a minimum. To ensure that the release of fibres from these RCF articles is kept to a minimum, during installation and servicing we recommend that you use a HEPA filtered vacuum to remove any dust and soot accumulated in and around the fire before and after working on the fire. When replacing these articles we recommend that the replaced items are not broken up, but are sealed within a heavy duty polythene bag, clearly labelled as RCF waste. RCF waste is classed as a stable, non-reactive hazardous waste and may be disposed at a landfill licensed to accept such waste. Protective clothing is not required when handling these articles, but we recommend you follow the normal hygiene rules of not smoking, eating or drinking in the work area and always wash your hands before eating or drinking.**
- This appliance does not contain any component manufactured from asbestos or asbestos related products.

ELECTRICAL SAFETY

Before switching on, please read the operating instructions fully.

- This appliance is not intended for use by persons (including children) with reduced physical, sensory or mental capabilities, or lack of experience and knowledge, unless they have been given supervision or instruction concerning use of the appliance by a person responsible for their safety.

- Children should be supervised to ensure that they do not play with the appliance.

- **NOTE:** This appliance is **ONLY** to be used with the power supply unit provided. Only plug this appliance into a supply that corresponds to that displayed on the power supply unit. The appliance must only be supplied at extra low voltage corresponding to the markings on the appliance.

- Plug positioning, the appliance **MUST** be positioned so that the plug/transformer is accessible. It is necessary to be able to disconnect the appliance from the mains electrical supply after installation. This could be achieved by incorporating a switch into the mains supply wiring in accordance with the rules in force. Do not use an extension lead.

- Unplugging, in the event of a fault unplug the device. It is also recommended to unplug the device when not required for long periods.

- Damage, if the transformer or its lead is damaged it **must be** replaced by the manufacturer or service agent or a similarly qualified person in order to avoid a hazard. Never attempt to cut the transformer lead so as to extend it.

- Where the transformer lead may have to pass through a fireplace, stone surround etc ensure suitable rubber bushes are fitted at possible wear points. Keep the transformer lead away from the front of the appliance and any hot areas inside the convector box and outside.

GDC Group is a licensed member of the Benchmark Scheme which aims to improve the standards of installation and commissioning of domestic heating and hot water systems in the UK and to encourage regular servicing to optimise safety, efficiency and performance.

Benchmark is managed and promoted by the Heating and Hotwater Industry Council. It places responsibilities on both manufacturers and installers. The purpose is to ensure that customers are provided with the correct equipment for their needs, that it is installed, commissioned and serviced in accordance with the manufacturer's instructions by competent persons and that it meets the requirements of the appropriate Building Regulations.

The Benchmark Checklist (on the inside back pages of this guide) can be used to demonstrate compliance with Building Regulations and should be provided to the customer for future reference. Installers are required to carry out installation, commissioning and servicing work in accordance with the Benchmark Code of Practice which is available from the Heating and Hotwater Industry Council who manage and promote the Scheme. Visit www.centralheating.co.uk for more information.



At the time of commissioning, complete all relevant sections of the Benchmark Checklist located on the inside back pages of this document.

INSTALLER GUIDE

Model	401FS in L or M Inspire Stove	401RC in L or M Stove
Gas	Natural (G20)	Natural (G20)
Input - Max (Gross)	5.3 kW (18,084 Btu / hr)	5.3 kW (18,084 Btu / hr)
FS Input - Med (Gross)	2.0 kW (6,824 Btu / hr)	-
Input - Min (Gross)	1.6 kW (5,459 Btu / hr)	2.25 kW (7,677 Btu / hr)
Inlet Test Pressure (Cold)	20.0 +/- 1.0 mbar (8.0 +/- 0.4in w.g.)	20.0 +/- 1.0 mbar (8.0 +/- 0.4in w.g.)
Gas Connection	8mm pipe	8mm pipe
Burner Injectors (X 3)	CAT15 – 150	CAT15 – 150
Pilot & Atmosphere Sensing Device	SEAGAS (01 / 73755 / 0)	SEAGAS P5-52 (01 / 74165 / 0)
Ignition	Electronic (Teddington gas valve)	Electronic (Tesc gas valve & handset)
UK/Eire 3 Pin Plug Transformer	12V 500mA AC/DC - 2m Cable with DC jack	12V 500mA AC/DC - 2m Cable with DC jack
LED On/Off Rocker Switch	Arcoelectric C1500XQ	Arcoelectric C1500XQ
8 LED lighting strip	03 / 23612 / 0	03 / 23612 / 0
LED PCB Controler	03 / 16805 / 0 (EP4031)	03 / 16805 / 0 (EP4031)

4. APPLIANCE DATA, EFFICIENCY, NOX AND Accessories

4.1 General information.

The appliance information label is located on the burner engine on the base of the fire. This can be found by removing the Visual Baffle.

4.2 Efficiency.

The efficiency of this appliance has been measured as specified in EN BS 613 and the results are as below :

<u>Models</u>	<u>Efficiency % (Gross)</u>	<u>Efficiency % (Net)</u>
Inspire Stove L inc 401FS/401RC	76%	84.5%
Inspire Stove M inc 401FS/401RC	76%	84.5%

The gross calorific value of the fuel has been used for this efficiency calculation.

The conversion of **net** efficiency to **gross** was achieved by multiplying the net efficiency by the following conversion factor from Table E3 of SAP 2005, rounding down to the nearest whole number.

Gas	Conversion factor from net to gross efficiency
Natural Gas	0.901
LPG	0.921

4.3 NO_x

For NG the 'Weighted' result for these appliances equates to NO_x Class 4.

5. GENERAL INSTALLATION REQUIREMENTS

5.1 Regulations, Standards and Law.

The installation must be in accordance with these instructions.

For the user's protection, in the United Kingdom it is the law that all gas appliances are installed by competent persons in accordance with the current edition of the Gas Safety (Installation and Use) Regulations. Failure to install the appliance correctly could lead to prosecution. GAS SAFE REGISTER require their members to work to recognised standards.

In the United Kingdom the installation must also be in accordance with all the relevant parts of local regulations.

BS 5440 Part 1

BS 5440 Part 2

BS 4543 Part 2

BS 5871 Part 1

BS 6891

BS 8303

In England and Wales, the current edition of the Building Regulations issued by the Department of the Environment and the Welsh Office.

In Scotland, the current edition of the Building Standards (Scotland) Regulations issued by the Scottish Executive.

In Northern Ireland, the current edition of the Building regulations (Northern Ireland) issued by the Department of the Environment for Northern Ireland.

In the republic of Ireland the installation must be carried out by a competent person and also conform to the relevant parts of:

- a) The current edition of IS 813 "Domestic Gas Installations"
- b) All relevant national and local rules in force.

Where no specific instructions are given, reference should be made to the relevant British Standard Code of Practice.

5.2 The Hearth.

The appliance must be mounted on a non-combustible hearth (N.B. conglomerate marble hearths are considered as non-combustible). The hearth material must be at least 12mm thick. The hearth must protrude at least 150mm (6") in front of the stove body. In most buildings with solid concrete floors this requirement will be met by the floor itself.

5.3 Clearances.

Clearances from combustible and non-combustible materials must be at least those shown in figure 2 (Page 8).

5.4 Flue / Chimney.

– Before you install the stove make sure the chimney flue outlet is correctly positioned to align with the flue outlet on the stove and that the chimney is in good condition. If not, a chimney liner must be installed or a suitable class 2 gas flue used.

The stove is approved for connection to a 102mm (4”) twin wall flue complying to BS715. A 127mm (5”) single wall “Decorative flue length” maybe fitted over the inner 4” twin wall. Any deviation from a vertical flue run should be kept to a minimum, an offset in the first 600mm of the flue is acceptable providing any deviation from the vertical is no greater than 45 degrees and the maximum distance of the offset is no greater than 200mm.

A draught is necessary to ensure the products of combustion are fully evacuated. Connect and seal the stove flue collar to the chimney using full depth of collar. The flue must have a minimum effective height of 3 metres (10ft), however, to ensure optimum performance we recommend 3.66 metres (12ft) or higher. The flue must be free of obstruction and any dampers must be fixed in a permanently open position. Ensure that the chimney is not closed and that it has been swept prior to the stove being installed. Make sure that rain, birds or any foreign bodies cannot get into the chimney and cause blockage or damage. This problem can normally be overcome by fitting an approved gas cowl. It is essential to the effective running of your stove that the chimney draws properly and allows the products of combustion to escape.

5.5 Ventilation.

– Normal adventitious ventilation is usually sufficient to satisfy the ventilation requirements of this appliance. In GB reference should be made to BS5871 Part 1 and in IE reference should be made to the current edition of IS 813 “ Domestic gas installations” which make clear the conditions that must be met to demonstrate that sufficient ventilation is available.

– An extractor fan may only be used in the same room as this appliance, or in any area from which ventilation for the appliance is taken, if it does not affect the safe performance of the appliance. Note the spillage test requirements detailed further on in this manual. If the fan is likely to affect the appliance, the appliance must not be installed unless the fan is permanently disconnected.

5.6 Location.

This appliance must not be installed in a private garage or any room, which contains a bath, or shower or where steam is regularly present.

5.7 The Atmosphere sensing device (ASD).

The appliance is fitted with an A.S.D (Atmosphere sensing device). If the appliance closes down after a period of operation for no apparent reason, the consumer should be informed to stop using the appliance until the installation and appliance have been thoroughly checked. The A.S.D will shut the appliance down if an unacceptable amount of harmful products of combustion accumulate. Under no circumstances should the A.S.D be altered or bypassed in any way. Only a genuine manufacturer’s replacement part should be fitted. The individual A.S.D components are not replaceable.

5.8 Fireguard requirements.

A fireguard complying with BS 8423 should be fitted for the protection of young children, the elderly, the infirm and pet animals.

5.9 An extractor fan may only be used in the same room as this appliance, or in any area from which ventilation for the appliance is taken, if it does not affect the safe performance of the appliance. Note the spillage test requirements detailed further on in this manual. If the fan is likely to affect the appliance, the appliance must not be installed unless the fan is permanently disconnected.

5.10 Do not place any flammable materials within a distance of the radiation of the appliance and ventilation grills, refer to figure 2 (page 8) for minimum limits.

5.11 Leveling the stove - The stove is supplied with four adjustable feet at the base of the outer casing. If necessary to level the stove turn anti-clockwise each foot required till the stove stands level.

5.12 Securing the stove - The stove is supplied with a floor fixing bracket pre-fitted to the rear of the stove casing. In the accessory kit there is provided a wood screw and wall plug.

To use the fixing bracket remove it from the rear of the stove casing by unscrewing the fixing screw, keep this screw safe for later reassembly.

Rotate the bracket around through 180 degrees as shown below. Adjust the height positions the four stove feet if necessary ensuring the stove is now level. When this is completed place the bracket into position making a hole in the floor surface to drill and fit the wall plug.

Fit on the bracket using the screw removed back to the stove body and tighten. With the bracket resting flat on the floor surface use the wood screw to secure the stove.

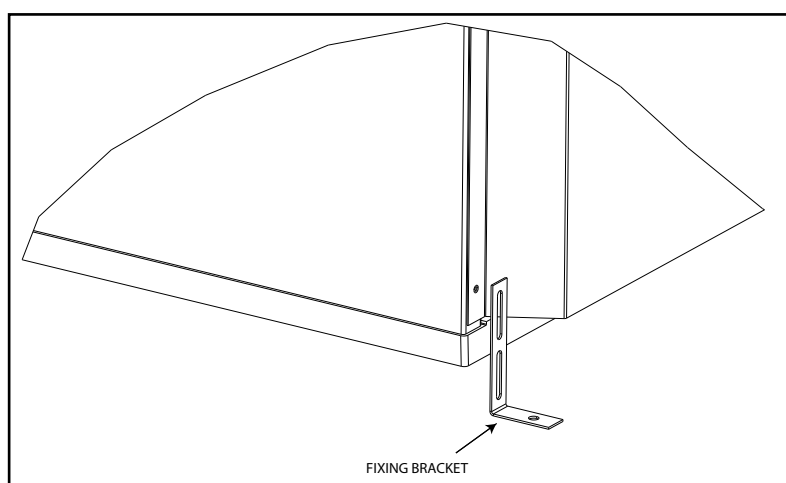

INSTALLER GUIDE

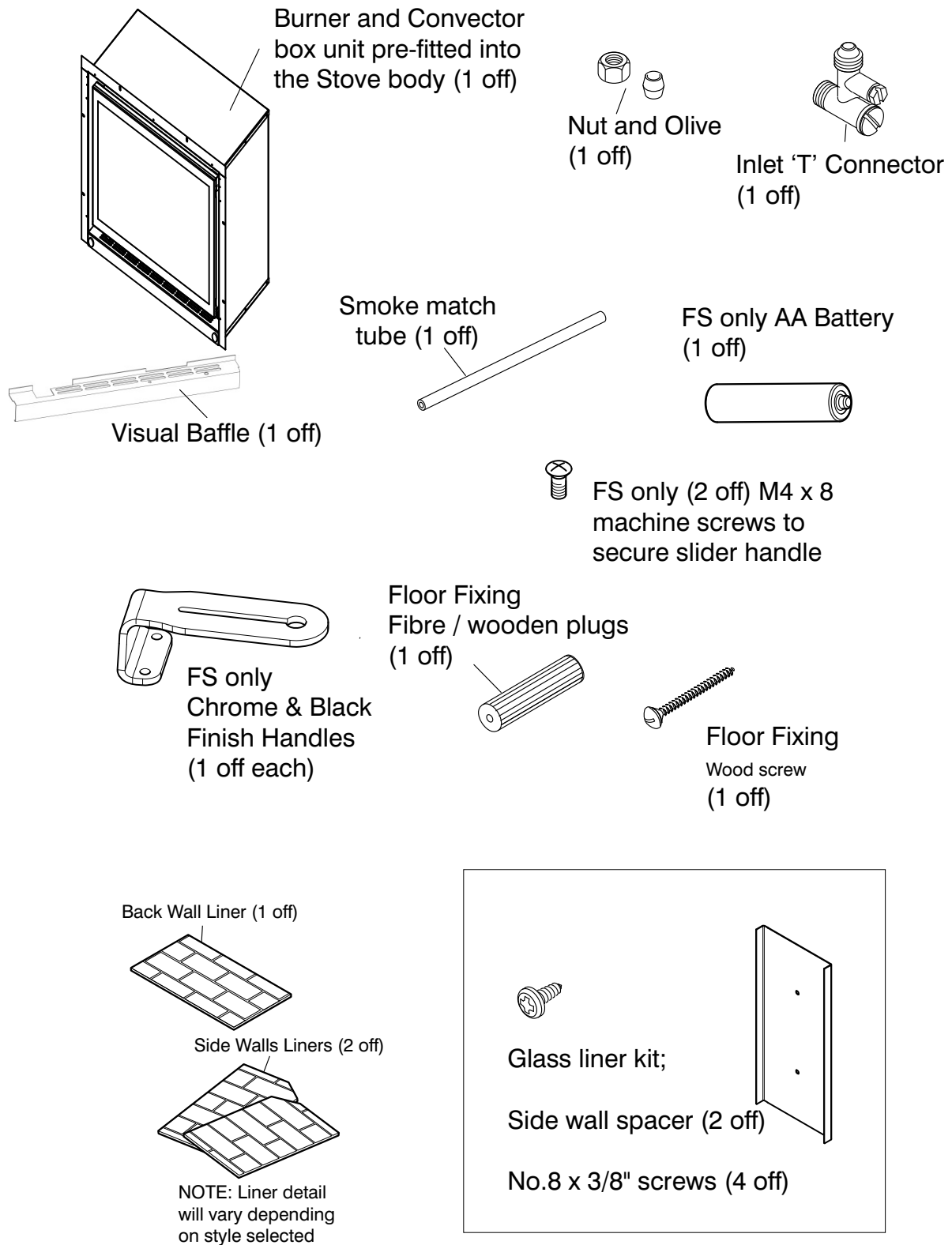

INSTALLER GUIDE

PACK CONTENTS

The items required for this appliance are packed in sections.

NOTE: The Log fuel set and Vermiculite or Glass liner options are all fragile, so care necessary when handling please.

Section 1 - Stove Fire unit contains:

- 1 Stove inc Burner, convection box unit and Floor fixing bracket.
- 1 Log fuel effect set inc Glass pebbles/Grey chips/Vermiculite flakes.
- 1 Literature packs

Section 2 - Accessory box contains:

- 1 Visual baffle
- 1 Wall liners set (2 sides and 1 rear piece)
- 1 'T' connector and pressure test point.
- 1 Nut and olive for 8mm inlet pipe.
- 1 Smoke match tube
- 2 Slider handles (Chrome or Black) (FS models only)
- 2 M4 x 8 machine screws (FS only - to secure the Slider handle)
- 1 Alkaline 'AA' Battery (FS models only)
- 1 Digital display Remote hand set (RC models only)
- 5 Alkaline 'AA' Battery (RC models only 2 for Handset / 3 for Valve)
- 2 Side wall glass spacers (Only on models with Glass liners selected)
- 4 No.8 x 3/8" Tapping Screws (Used to fit the side wall spacers)
- 1 Wood screw (Used with Floor fixing bracket)
- 1 Wall plug (Used with Floor fixing bracket)

Check that all the listed parts are present and in good condition.

INSTALLER GUIDE

8 .GAS SUPPLY CONNECTION

The stove is designed for a rear connection only.

A nut and olive are provided for an 8mm pipe inlet connection to the 'T' connector at the bottom front of the appliance. The 'T' connector can be rotated to allow connection and includes a valve for isolating the gas supply and a pressure test point. The supply pipe must be rigid material. Flexible pipe must not be used.

9 . PREPARING APPLIANCE FOR INSTALLATION

1. Remove the glass door, by unscrewing by hand the single M5 knurled screw in an anti clockwise direction located just under the base of the door frame in the middle. Keep these screw save as it will be needed later. Carefully lift out at the base then up and away from the convection box. Place carefully to one side.

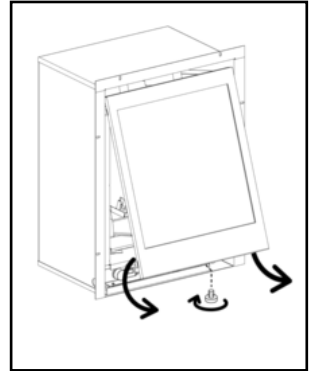

2. Lift out carefully the Log set carton, carefully placing to one side and the protective cardboard over the burner tubes.

3. To lift up and out the fuel bed outer top tray first unscrew the four screws as shown and carefully place tray and screws to one side.

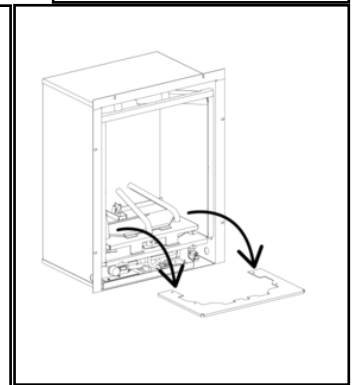
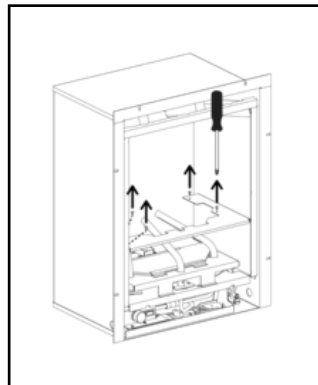

4. Detach the burner tray from the convection box by removing four locating screws. Slide the burner tray forward and clear of the convection box, taking care not to catch any of the wires to the Ignition unit on the LHS off the magnet for the Visual baffle.

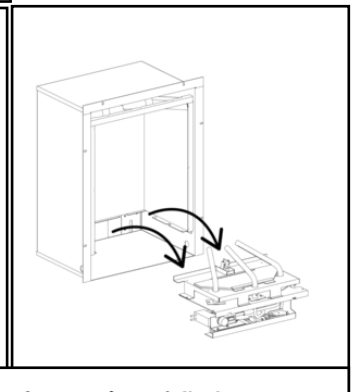
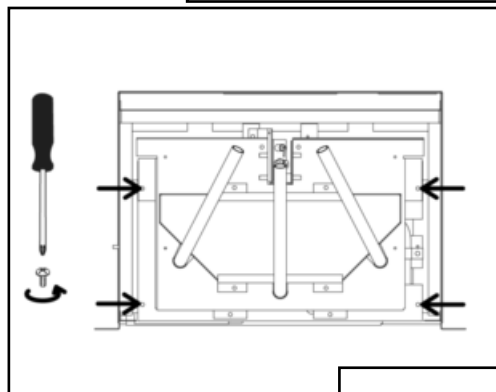

Place the screws and engine assembly to one side carefully.

5. It is important that the inlet cover plate is fitted as shown to cover the entry hole in the inside rear of the convection box. The inlet cover plate has a slot to allow the pipe to pass through its center. The slot is larger than the 8mm pipe so the remaining open area should be sealed with tape after the pipe is located.

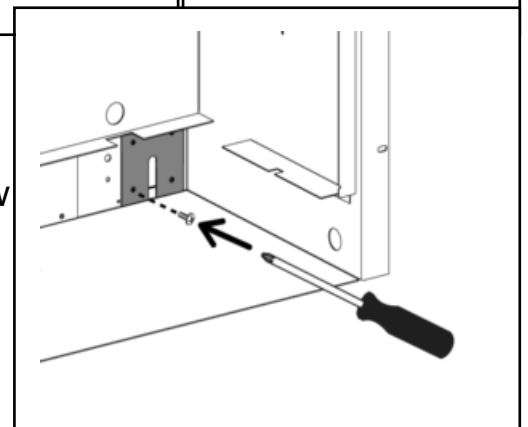

Before attempting to install, it is worth checking that the ignition system performs satisfactorily.

Slider Control (FS) Model

NOTE: 2 handle finish options have been supplied Chrome and Black please ask the customers preference before selecting one to be fitted.

10.1 Fitting slider handle to control cam.

10.1a. To gain access to fit the two screws into the slider handle first remove the 2 brackets as shown held in position by 2 screws into each. Lift out these brackets and keep safe. With the brackets removed carefully lift out the glass over the LED strip along with the seal below.

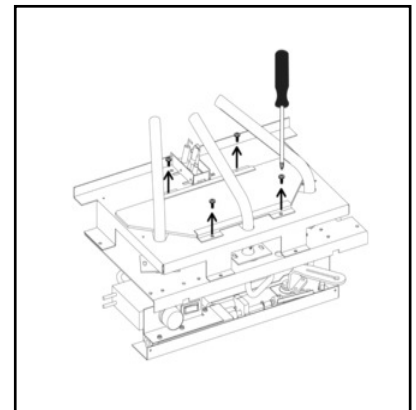

10.1b. As shown remove the 3 screws securing in place the inner fuel bed top tray. Carefully slide out the tray over the three burner tubes.

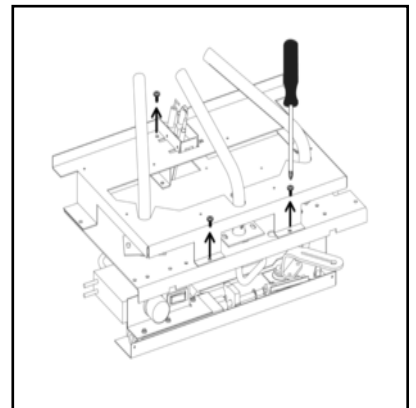

10.1c. With the previous sections removed (1a - 1b) you now have access to the Slider handle cam assembly below the middle burner tray as shown. With the Cam in the off position and using the two clearance holes in the middle burner tray hold the slider handle in position and ideally with a magnetic tipped philips head screwdriver fit the handle to the cam using the two M4 x 8mm screws supplied.

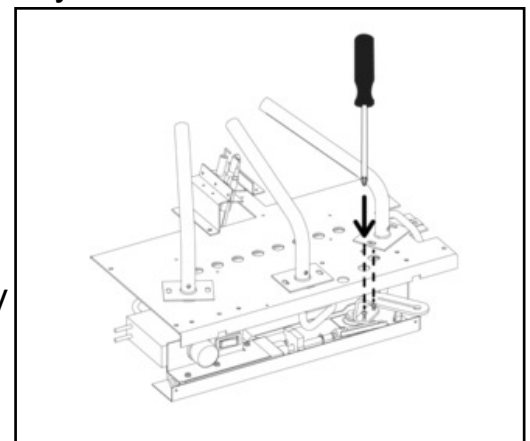

10.1d. After the slider handle is fitted to the cam carry out steps 1a - 1c in reverse order to reassemble.

10.2 Fitting the battery into the spark ignition generator.

At the front of the electronic spark generator there is a removable circular battery cover. Unscrew the cover in an anticlockwise direction. Remove any protective film from the battery if applicable and place into the generator. The negative (-) terminal should go in first. The battery is marked with (+). Screw back on the cap.

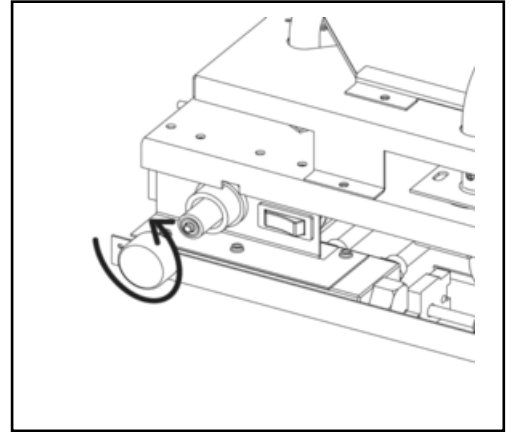

10.3 Checking the ignition operation.

– Push the slider handle to the LEFT as far as possible till the ignition is visible, several sparks should be generated and heard between the electrode and pilot tip.

– If there are no sparks check the following:
– Ensure that the electrode lead is connected to the terminal at the base of the electrode.
– If the above is correct, check for damage to the electrode lead and that the battery has been correctly fitted.

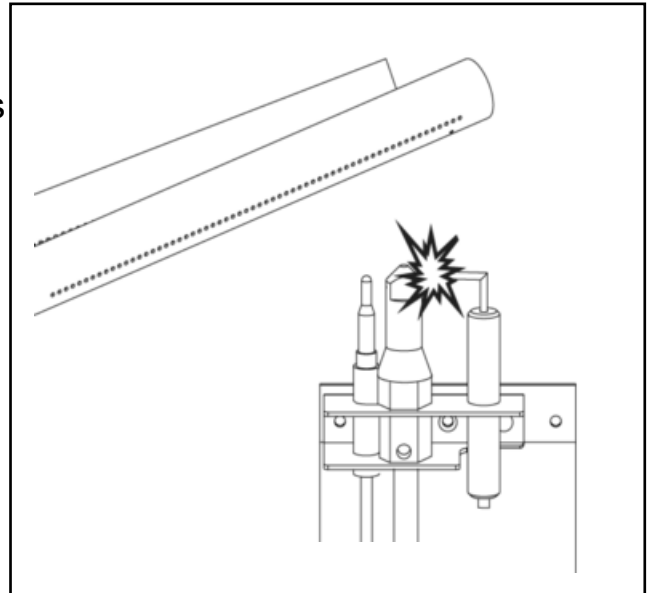

Remote Control (RC) Model

10.4 Fitting batteries into the remote control handset.

The remote control handset is battery powered. There are two 1.5 Volt Alkaline 'AA' size batteries supplied. Remove the rear battery compartment cover from the remote control handset. Fit the batteries in to the handset. Replace the cover.

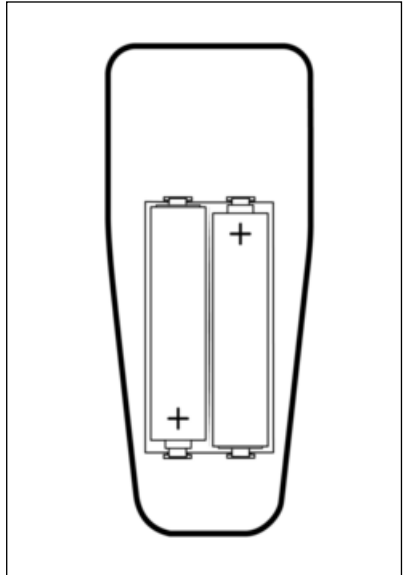

10.5 Fitting batteries into the Valve.

The gas valve is battery powered. There are three 1.5 Volt Alkaline 'AA' size batteries supplied. Locate the batteries in the valve, remove the front battery compartment cover from the valve and fit the batteries.

It is important that the positive (+ve) and negative (-ve) symbols on the battery match those of the illustration inside the battery holder. Replace the cover.

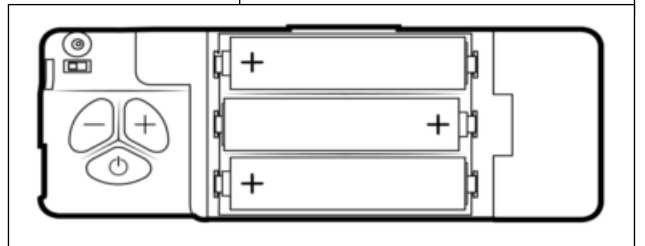

10.6 Setting the handset and receiver relationship.

The receiver and handset are linked before leaving the factory but if either component are replaced the receiver will have to be set to learn the handset / remote code. Do this as below:

- Picking up and holding the handset will unlock the keypad and the green light will illuminate a solid green.

NOTE: Ensure the small isolation slide switch on the top left of the gas fire control is slid to the right, (I) position to turn the power on to the valve.

- Place the handset near the fire, i.e.within a metre. No need to hold the handset at this time.

- Simultaneously press and hold the - and + buttons on the gas valve control (not the handset) until the red light on top left of fire control begins to flash rapidly,(it will take about 5 seconds to start flashing), then immediately release the - and + buttons and quickly pressing just the power button on the gas fire control valve. Note: Pressing of the power button must be done within 1 second of the red light coming on. If not done quickly enough, then the above must be repeated until done correctly.

- When done correctly you will hear an audible sound from the handset and the display will show the symbol " | - | " and the green light on the handset will be flashing. You now have 60 seconds to accept the pairing. To do this pick up and hold the handset and hold it like a handshake to activate the unlocking of the keypad and press and hold the "SET" button for a few seconds.

- You will hear a few beeps from the handset and the display will change and enter the setup menu .

- Whilst maintaining your grip on the handset, you can now set the display functions



INSTALLER GUIDE

of the handset. Momentarily pressing and releasing the SET button advances through the settable features and pressing and releasing the MENU button returns to the previous one. Pressing + or – changes the displayed information, for example :-
o H 24 – This is the 12 hr or 24 hours time format. Pressing and releasing + or – will change H24 into H12. Once happy with that setting, press and release SET to move to the day of the week.

o Day of the week is Mo, Tu, We,Th,Fr, Sa, Su. Again pressing and releasing +/- will change the day and when happy press and release SET to move to the hour of the day.(Pressing Mode button

– Within the subsequent 20 seconds press the ‘DOWN’ button on the handset until you hear an additional long signal confirming the code is set

NOTE: Please inform the customer that this is a one time setting and is NOT required when changing batteries in the handset or battery box.

10.7 Factory reset of handset

As stated in 10.6 the remote receiver is already linked, but in the event it is needed to reset the remote receiver back to factory reset, “breaking all links to the valve” follow these steps;

Activate the handset, then press and hold SET until SETUP is flashing. Keep pressing SET until CA0 appears on the screen, use + or – to change to CA1. Then press SET.

The handset should now read TESC r5 (7ESC r5), and is ready to be paired with the valve.

10.8 Checking the ignition operation.

– Picking up and holding the handset will unlock the keypad and the green light will illuminate a solid green.
- Press and hold the ‘ON’ power button (approx 1 - 2 seconds), then release as soon as the word “PILOT” appears at the bottom left of the display this confirms the start sequence has begun.

– There will be a slight delay and several sparks should be seen between the electrode and pilot tip.

– On sensing a flame is not present the burner unit will shut off. If there are no sparks check the following:

– Ensure that the electrode lead is connected to the terminal at the base of the electrode. If the above is correct, check for damage to the electrode lead and that the batteries have been correctly fitted.

10.9 Error codes

During the setup process Error codes could be generated on the handset (i.e. E00). These can be reset/cleared by;

Activate the handset, then press and hold ‘ON’ power button continuously for 3 - 5 seconds. If the errors repeat first ensure brand new Alkaline batteries are fitted into the remote control and valve as low powered batteries can generate different error codes. Failing that please contact our customer service for further assistance.

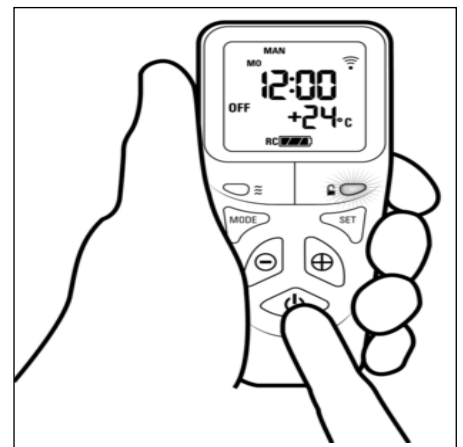

Before attempting to install, it is worth checking that the LED system performs satisfactorily.

11.1 Fitting the transformer's male DC jack connector into the convection box.

At the front LHS and RHS of the convector box are access grommets fitted. These allow for the routing of the transformer lead & DC jack into the convection box. This feed is possible from either side to accommodate the location of your 13 amp 1 Gang Double pole wall socket. (Compliant with BS 1363 Part 2). Pierce the rubber grommet selected to feed through the male connector, leaving the other intact.



11.2 Connecting the male and female DC jack to the LED circuit.

Push the male DC jack connector into the female DC jack connector. Ensure they are pushed together fully.

NOTE: The remaining wire from the DC Jack back to the transformer **MUST** be left outside the convector box and **NOT** left in at the base of the burner assembly.

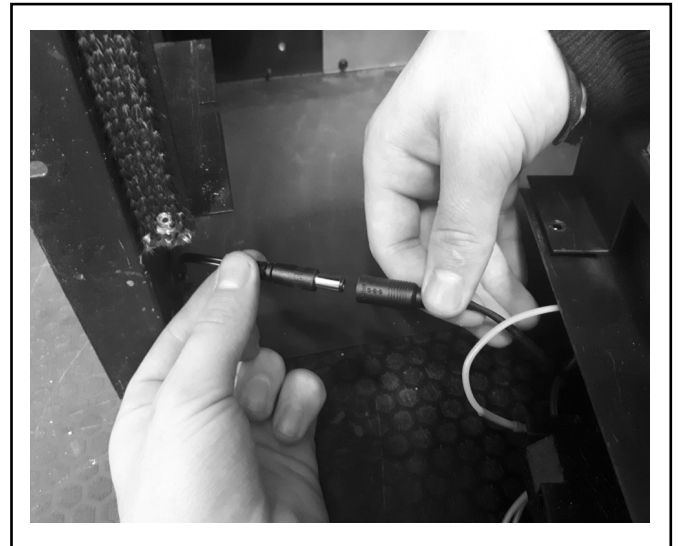

11.3 Checking the LED operation.

Ensure the transformer is plugged into a suitable mains supply and the wall socket is switched ON.

Switch on the LEDs by push ON the rocker switch as shown. The 8 LEDs will come on and begin gently pulsing.

NOTE: If no LEDs function check all switches are in their ON positions, the DC jacks are fitted correctly and there are no loose connections in the circuit.

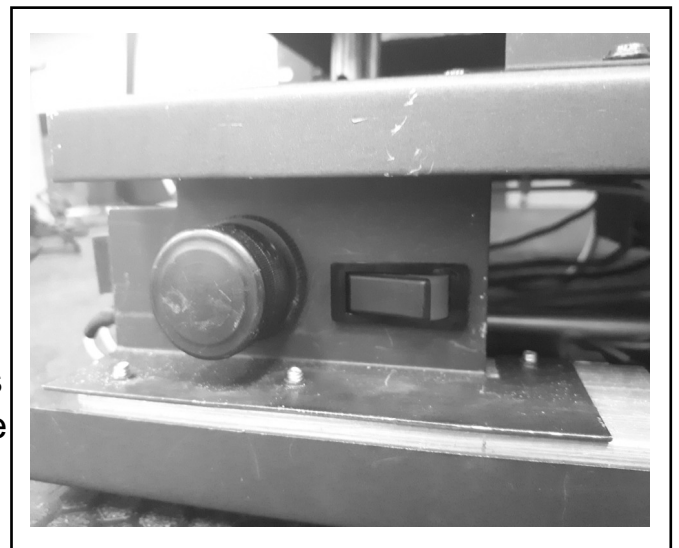

NOTE: The LED circuit is separate to that of the gas and its ignition circuit, so they can both be checked separately or together.

FITTING THE WALL LINERS

There are a range of wall liners available some may have a patterned/colouring or in the case of the glass a mirrored side depending on the liner set purchased. Ensure the decorated or glass mirrored side is fitted facing outwards.

NOTE: All liners must be fitted into the convector box before the engine is refitted.
PLEASE NOTE: Care must be taken to avoid damage to the liners when fitting.

13.1 Fitting the rear wall liner.

Locate the rear liner against the rear wall of the convector box.

Please note that when fitting this liner into the convector box it should be angled first on the flat to fit inside the inner convector box then gently raised to locate into the rear wall section.

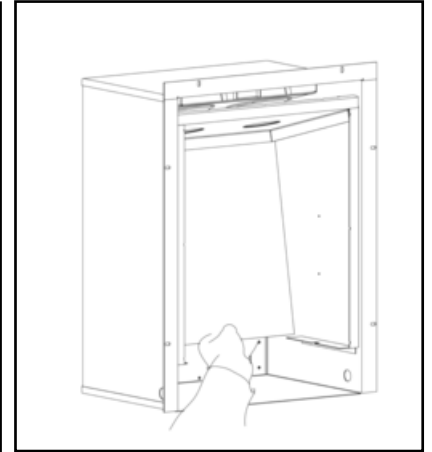
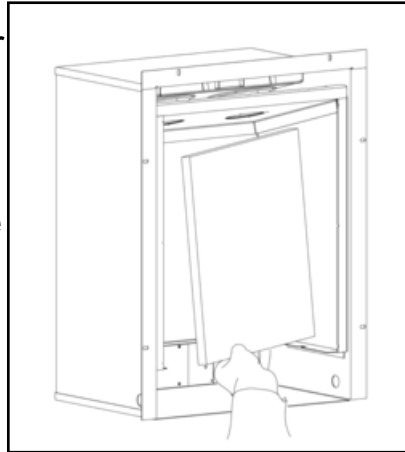

13.2 Fitting the Glass liners spacer support.

NOTE: This must be carried out before fitting any of the Glass wall liners.

Inside the accessory box you will find two metal spacer brackets and 4 screws. Locate the glass liner spacer to the LHS and RHS of the convection box using the 4 screws supplied.

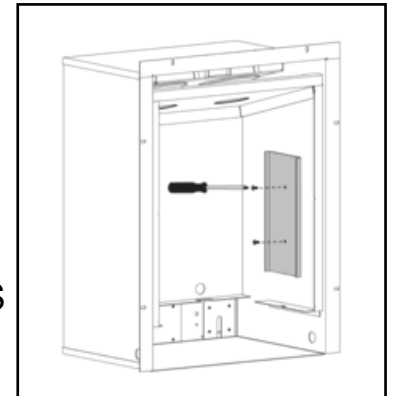

13.3 Fitting the side wall liners.

Offer the side wall liners into the convection box. The angled top of the ceramic side walls should be located first. With the top in place gently slide the side wall until it is flat against the side of the convection box.

Ensure they are pushed in fully both sides so as not to interfere when refitting the burner assembly.

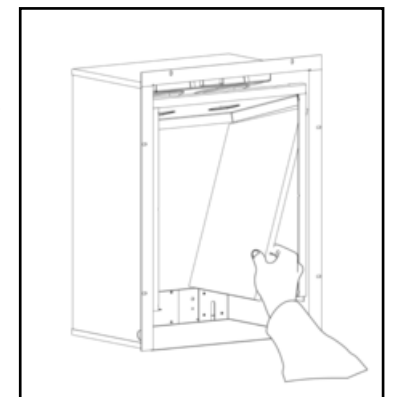

14. BURNER AND SUPPLY PIPE INSTALLATION

14.1 Burner installation.

1. Ensure the transformer location is confirmed and the DC jack connector is fitted through the grommet into the convector box as described in (Section 11) and connected to the burner unit.
2. Refit the burner unit to the convection box with following the steps and with the screws removed previously in (Section 9).

14.2 Supply pipe installation.

1. A nut and olive is provided for an 8mm-pipe inlet connection directly to the gas control. The isolating 'T' connector can be rotated to allow a connection from the rear. The 'T' connector includes a valve for isolating the gas supply. The supply pipe must be rigid material. Flexible pipe must not be used. Connect the supply line to the appliance.

2. If closed, open the isolating valve at the inlet 'T' connector.

3. Turn on the gas supply and pressure check the installation pipework for gas soundness. In the United Kingdom (GB) check in accordance with the current edition of BS 6891. In the Republic of Ireland check in accordance with the current edition of IS 813 "Domestic Gas Installations".

Some burner operations can be checked at this stage along with the function of the LEDS. Checking now will mean that less disassembly will be required if any problems are found.

NOTE: A full check should still be made, however, after final installation. Only leave the burner alight long enough to confirm its operation.

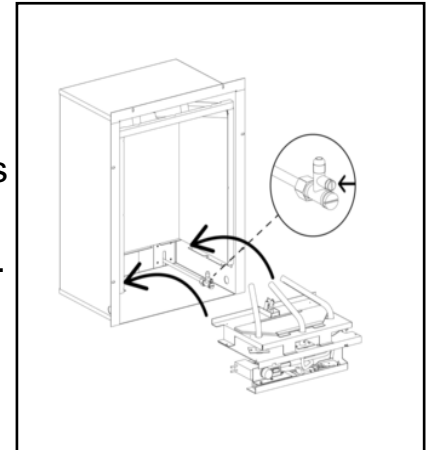

14.3 Burner checks - FS model

- 14.3.1 Lighting the fire.

If closed, open the isolating 'T' connector valve.

– Push the slider handle to the LEFT as far as possible till the ignition position is reached, several sparks will occur between the electrode and pilot tip. Hold in this position till the pilot flame has heated the thermocouple sufficiently to hold.

Approx. 5 - 15 seconds.

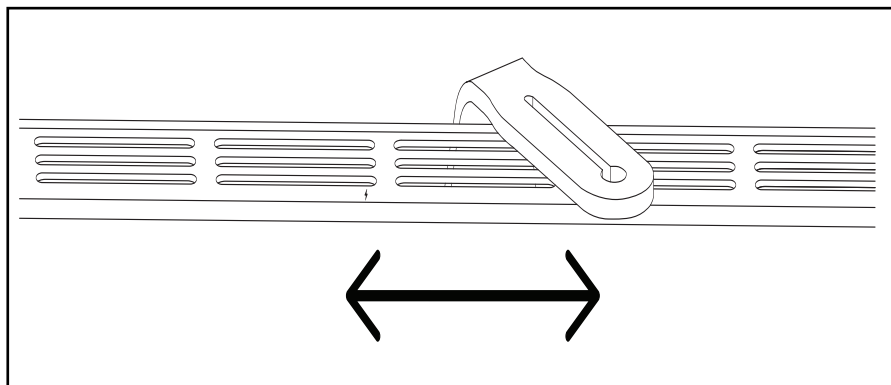

- 14.3.2 Adjusting flame height.

When the burner is operating step the slider handle to the RHS, increments will be felt as the slider moves giving you the following outputs;

Position 1 - After ignition Center burner is on LOW

Position 2 - Moving slider handle one increment to RHS, Center burner is on HIGH.

Position 3 - Moving slider handle one more increment to the RHS, both Rear burner on HIGH ignites (along with the Front burner remaining on HIGH)

Position 4 - Moving the slider as far as possible to the RHS is OFF

Note: *There is no “pilot only” setting on the Slider (FS) model.*

14.3.3 Turning off.

To turn the fire OFF push the slider as far as possible to the RHS.

14.4 LED fuel effect checks.

- 14.4.1 Lighting the LED fuel effect.

Flick the rocker switch to the ON position which will be visible by a red marking on the rocker switch and the LED effect will illuminate and begin pulsing.

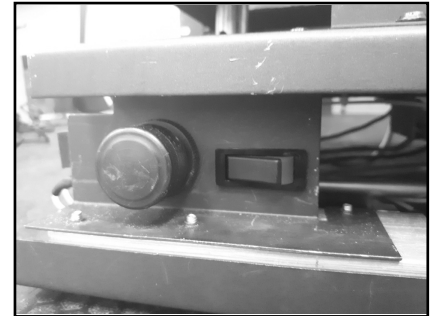

14.4.2 Turn off.

To turn the LED fuel effect OFF flick the rocker switch in the opposite direction.

NOTE: The Gas fire and the LED fuel effect can function independant of each other.

14.5 Burner checks - RC model

- 14.5.1 Lighting the fire.

If closed, open the isolating 'T' connector valve.

- Picking up and holding the handset firmly will unlock the keypad and the green light will illuminate a solid green.

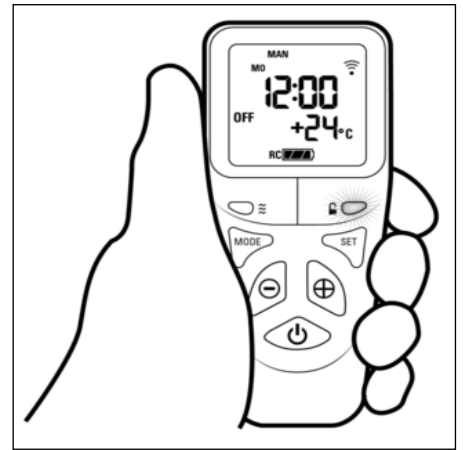

- Press and hold the 'ON' power button (approx 1 - 2 seconds), then release as soon as the word "PILOT" appears at the bottom left of the display this confirms the start sequence has begun to ignite the three burners on min setting.

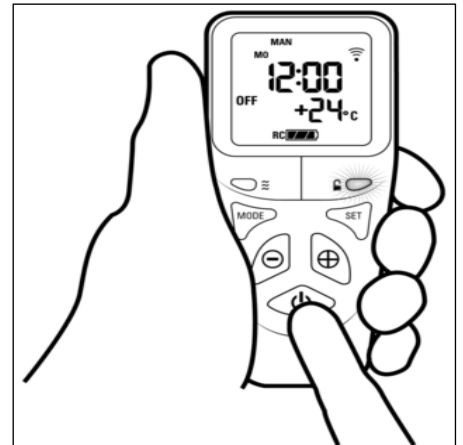

NOTE: There is no "pilot only" setting on the RC model.

- 14.5.2 Adjusting flame height.

- To adjust the flame, hold the handset to enable the buttons to work and press and hold the + button to increase the flames accross all 3 burners together.

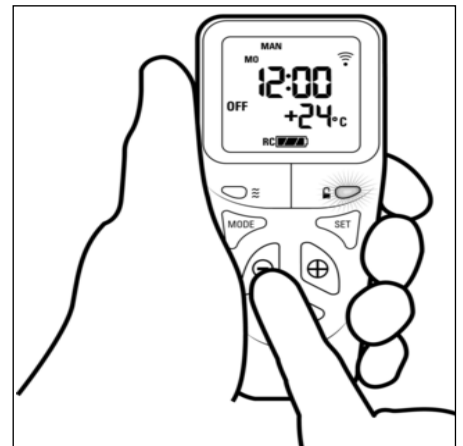

Tapping the button will adjust the flames step by step. Holding the button will skip through the steps. Similarly, press the - button to reduce the flame height.

14.5.3 Turning off.

- To turn off the fire, hold the handset to unlock the buttons and then press the power button. The fire will turn off.

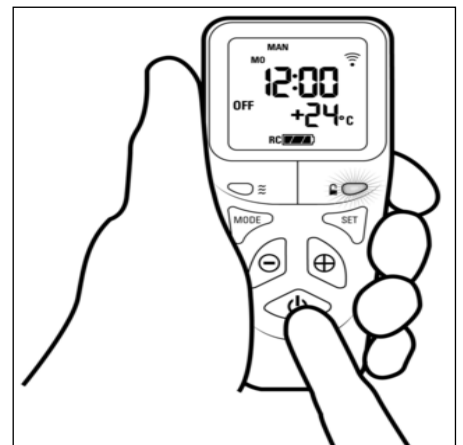

NOTE: Wait for the word 'OFF' to appear on the display before trying to start again.

INSTALLER GUIDE

14.6 Check inlet pressure.

The appliance is pre-set to give the correct heat input at the inlet pressure shown in section 4 of this guide.

1. Ensure that the fire is **OFF** then fit a pressure gauge at the test point. The test point is on the inlet 'T' connector. Turn the fire ON and check the pressure with the appliance alight and set at maximum output.
2. After checking, turn off the appliance. Remove the pressure gauge and replace the test point sealing screw.
3. Test around the sealing screw for gas soundness with a suitable leak detection fluid.

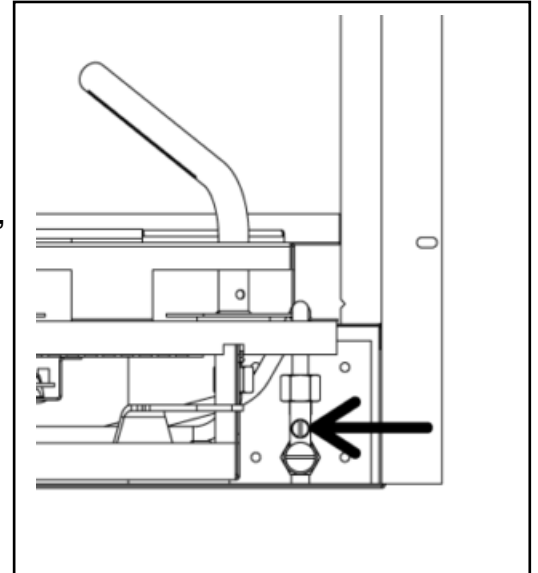

15. REASSEMBLE OF FIRE & LOG SET LAYOUT

The remaining parts that were removed earlier now need to be refitted;

- 15.1 Secure the burner unit into the convector box using the screws removed earlier.
- 15.2 The top tray requires screwing back in position.
- 15.3 Install the log set and decorative components supplied
 - 15.3.1 Fit the 4 small logs as shown in the picture. Two fit at the rear and the other two at the front running back between the 3 burner tubes.

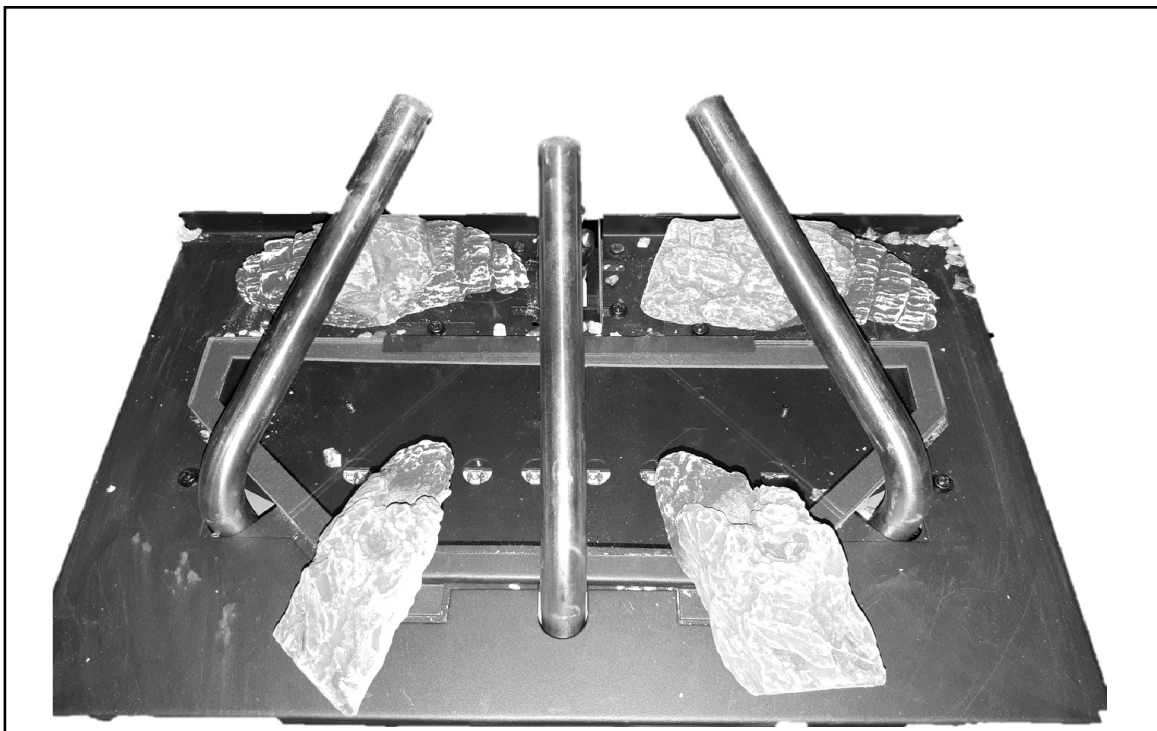

INSTALLER GUIDE

15.3.2 Open the bag of Clear Glass Pebbles (approx 700g) and carefully empty out the entire contents as in the below picture. The use of Gloves is recommended. The glass pebbles need to fully cover the glass panel evenly above the LEDS and flow out to the sides but not to the front or rear of the Top tray.

NOTE: Care is needed when laying out to ensure no pebbles rest against or fall down where the pilot unit is located to the rear.

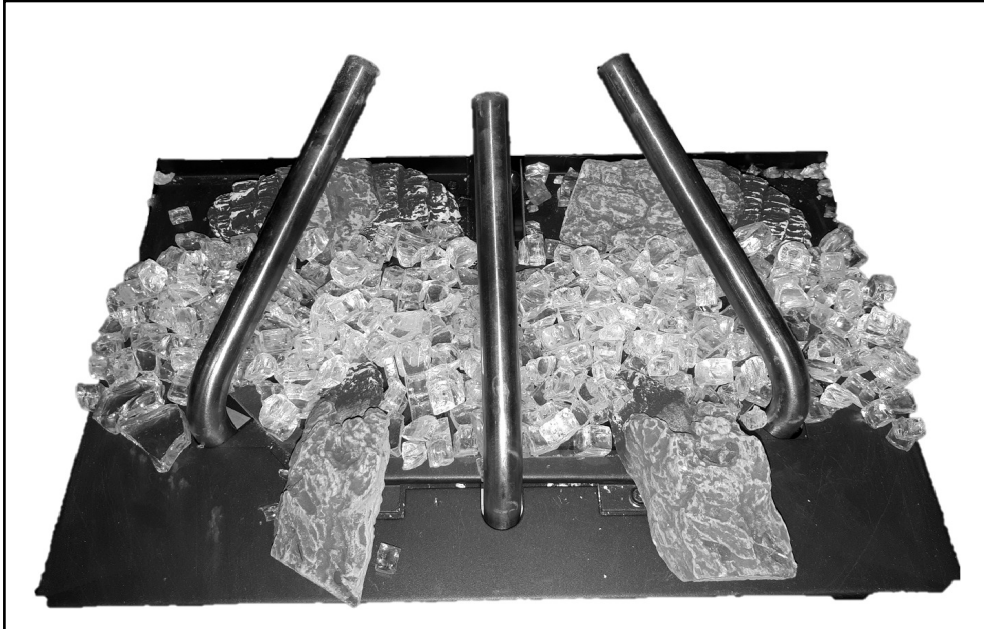

15.3.3 Open the bag of Grey Vermiculite Chips (approx 400g) and carefully layout the entire contents as in the below picture to the outsides of the top tray. Larger chips can be broken up to achieve the desired effect.

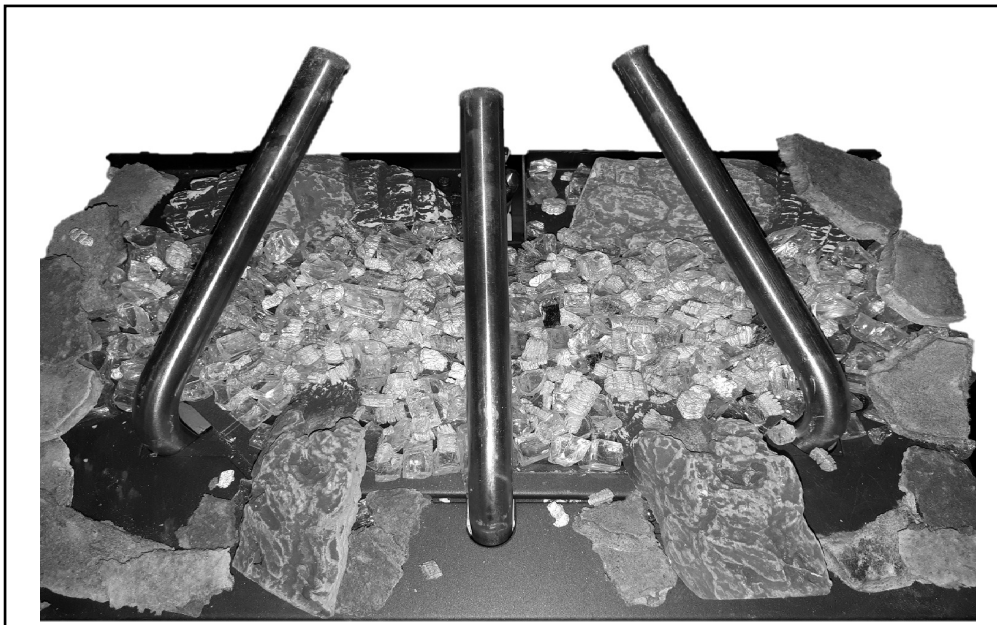

Open the bag of Natural Vermiculite Flakes (approx 100g) and carefully spread out the entire contents as in the above picture, evenly scattered on top of the glass pebbles and flow out to the sides but not to the front or rear of the Top tray.

NOTE: Care is needed when laying out to ensure no chips or flakes rest against or fall down where the pilot unit is located to the rear.

INSTALLER GUIDE

15.3.4 Fit the three large logs as shown in the below picture. The logs are marked on their underside with 1, 2 or 3 dimples to identify them running left to right as in the below picture.

NOTE: Ensure when laying these three logs in place, that no pebbles, chips or flakes interfere with how they sit onto the burner tubes. Clear any such items away from the base of the logs on the Top tray before placing.



15.4 Refit the window door panel, hook the top of the window door panel onto the top of the inner convector box. Lower the glass door till it covers fully the opening of the inner convector box. Screw back into place as before by hand with the M5 knurled screw in a clockwise direction just under the center base of the window door frame. These screws only require to be hand tightened closed.

15.5 Replace the visual baffle, carefully slide back into place as before the visual baffle. The magnets on the convection box will hold it in position.

16.1 Check the burner operation.

Repeat the checks conducted in section 10 & 11.

Please note:

When first turned on from cold, the flames will appear predominantly blue.

When operating the fire for the first time, some vapours may be given off which could set off smoke alarms in the vicinity. These vapours are quite normal with new appliances. They are totally harmless and will disappear after a few hours use.

16.2 Check for spillage.

A spillage check must be made before leaving the installed appliance with the customer.

The spillage check must be conducted.

1. Close all doors and windows in the room containing the appliance.
2. Light the appliance and set the control to its highest heat position.
3. Leave the appliance on for five minutes.
4. At the top of the heater are two openings. The upper opening has a tapered rear that has an opening of its own. The smoke match should be placed horizontally into this opening so that it touches the right hand side of the opening 100mm deep. It should pass the upper part of the opening by 25mm.

The installation is satisfactory if the smoke is drawn into the appliance.

If the smoke is not drawn into the appliance leave the appliance alight at the maximum setting for a further ten minutes and then repeat the test. If smoke is still not drawn into the appliance **disconnect the appliance and seek expert advice.**

5. If the above test is satisfactory open all internal connecting doors, hatches, etc. in the room. Keep all doors and windows that open to the outside of the building closed. Recheck for spillage as above. If an extractor fan is installed in the same room as the appliance or a connecting room, check that spillage does not occur with the fan operating and all doors and other openings between the fan and the appliance open.

If the smoke is drawn into the appliance, continue with the installation. If the test is not satisfactory

disconnect the appliance and advise the customer of the cause of failure.

16.3 Flame supervision and spillage monitoring system.

This pilot unit includes a system that will automatically shut off the gas supply if the pilot flame goes out or if there is insufficient oxygen due to spillage or poor ventilation.

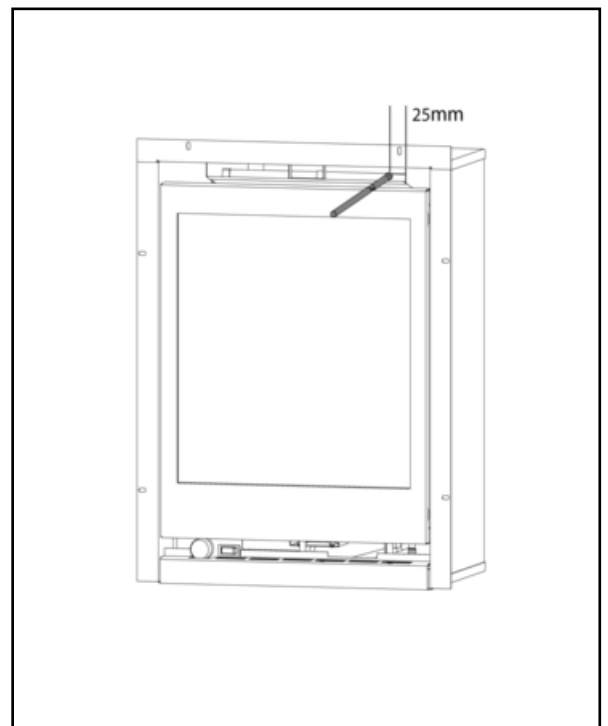

INSTALLER GUIDE

This monitoring system must not be adjusted, bypassed or put out of operation.

This monitoring system or any of its parts must only be exchanged using Valor authorised parts.

18.

FINAL REVIEW

- 1. COMPLETE THE INFORMATION IN THE GAS FIRE COMMISSIONING CHECKLIST AND SERVICE RECORD OF THE OWNER GUIDE (See last pages of the OWNER guide).**
2. Visually inspect the appliance. Clean off any marks incurred during installation.
3. Advise the customer how to operate the appliance. Explain to the customer that the appliance has a flame failure & spillage monitoring system. Point out the explanation of this system shown in the owner guide under "Operating the fire". Advise that if the fire goes out for any reason, wait at least three minutes before relighting. Stress that if the monitoring system repeatedly shuts off the fire, the appliance should be switched off and a specialist should be consulted.
4. Advise the customer that they should read their owner guide before operating the fire and always follow the advice in the section headed "Cleaning your fire".
- 5. Stress that no extra ceramic fuel effect pieces or ember wool must be added over and above those supplied with the appliance and that any replacements must only be the authorised spares. Warn that ignoring this advice could cause incomplete clearance of the products of combustion with consequent health hazards. If you have not done so already; attach or place the ceramic fuel effect guide inside this guide.**
6. Advise the customer that the appliance will operate to its maximum potential if the flue is primed during the first 20 – 30 minutes of use. To do this, simply set the control to its highest setting. This will also burn off any carbon deposits that may have formed during previous use.
- 7. Emphasise that if the glass panel is broken or damaged, the fire should be turned off and not used until the window unit is refitted with an authorised replacement. The fire should not be used without the glass panel fitted.**
8. Advise the customer that when first turned on from cold, the flames will appear predominantly blue and it is normal for condensation to form on the rear of the glass panel. The condensation will disappear after a few minutes use.
9. If using the appliance for long periods it is beneficial to change between settings. This will also help to remove any carbon deposits that may form during use.
10. Recommend that the appliance should be serviced by a competent person annually.
11. If the appliance is in premises in the United Kingdom occupied by a tenant, point out that by law a landlord must have any gas appliance, flue and pipework which is situated in a tenant's premises checked for safety at least every 12 months.

INSTALLER GUIDE

12. Advise that the appliance may give off a slight odour while new. This is quite normal and it will disappear after a short period of use.

13. Inform the customer that the Serial number for the appliance is located on the information label, located to the base of the burner and also stuck into this manual

14. Hand the literature packs with this guide to the customer.

19. SERVICING & PARTS REPLACEMENT

– Always turn off the gas supply before commencing any servicing and allow the fire to cool completely (The appliance inlet ‘T’ connector incorporates an isolating valve).

– This product uses fuel effect pieces, burner compartment walls and ceramic logs containing Refractory Ceramic Fibres (RCF), which are man-made vitreous silicate fibres. Excessive exposure to these materials may cause irritation to eyes, skin and respiratory tract. Consequently, it is important to take care when handling these articles to ensure that the release of dust is kept to a minimum. To ensure that the release of fibres from these RCF articles is kept to a minimum, during installation and servicing we recommend that you use a HEPA filtered vacuum to remove any dust and soot accumulated in and around the fire before and after working on the fire. When replacing these articles we recommend that the replaced items are not broken up, but are sealed within a heavy duty polythene bag, clearly labelled as RCF waste. RCF waste is classed as a stable, non-reactive hazardous waste and may be disposed at a landfill licensed to accept such waste. Protective clothing is not required when handling these articles, but we recommend you follow the normal hygiene rules of not smoking, eating or drinking in the work area and always wash your hands before eating or drinking.

– Check that the appliance is clean and that soot or debris is not blocking the gaps between the ceramic fuel effect pieces causing an imperfect flame.

– Check that soot or debris is not impairing the electrode spark or pilot burner.

– Check that soot or debris is not blocking any of the slots in the main burner.

– After servicing, make sure that the ceramic walls are replaced and the ceramic fuel effect pieces are replaced correctly as described in the installer and owner guide supplied with the ceramic fuel effect. The ceramic fuel effect guide may have been placed inside or attached to this guide.

– Always test for gas soundness and spillage after servicing the appliance.

19.1 To remove the visual baffle.

1. Remove the visual baffle held in place by two magnets, hold securely and carefully slide out the decorative trim and place carefully to one side.
3. Replace in the reverse order.

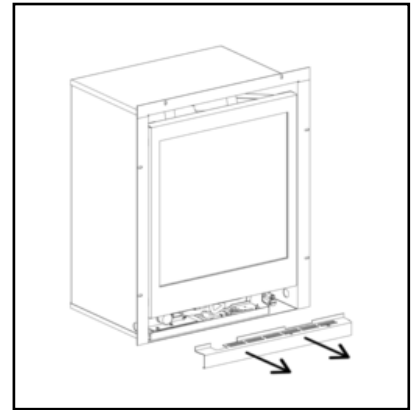

19.2 To remove the window door panel.

1. Complete section 19.1
2. Remove the glass door, by unscrewing by hand the single M5 knurled screw in an anti clockwise direction located just under the center base of the door frame. Keep this screw save as it will be needed later. Carefully pull out at the base then lift up and off the door and place carefully to one side.
4. Replace in the reverse order.

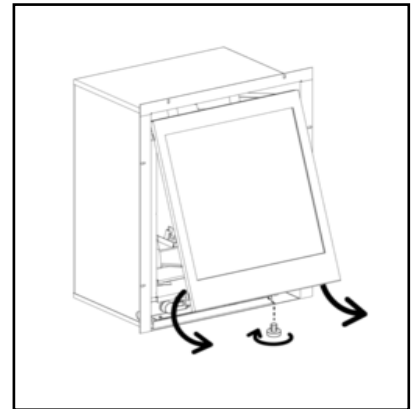

19.3 To remove the fuel effect.

1. Complete sections 19.1 - 19.2
2. Remove the fuel effect in the reverse order to that shown for fitting in Section 14. To gather the smaller decorative items pebbles/chips/flakes a clean storage basin is recommended. The ceramic fuel effect may cause staining / discolouration to decorative surfaces. It is therefore advisable to protect decorative surfaces.
3. Replace all in the reverse order following the original steps in Section 14.

19.4 To remove the top tray.

1. Complete sections 19.1 - 19.3
2. Unscrew and lift out the Top tray and carefully place to one side.
3. Replace in reverse order.

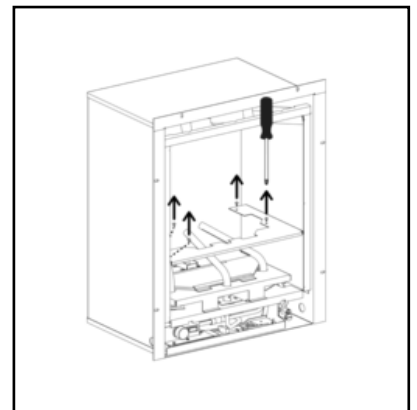

19.5 To remove the burner assembly.

1. Complete section 19.1 - 19.4
2. Isolate the gas supply at the inlet isolating 'T' connector.
3. Support the inlet 'T' connector to avoid straining the pipework and disconnect the appliance from the inlet 'T' connector.
4. Unscrew the burner tray from the convection box by removing four locating screws.
5. Slide the burner tray unit clear of the convector box, taking care not to catch any of the wires to the Ignition unit on the LHS off the magnet for the Visual baffle.
6. Replace in the reverse order.

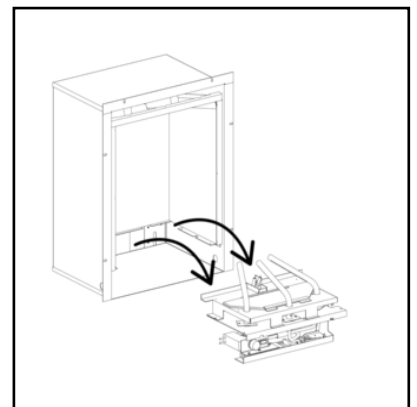

INSTALLER GUIDE

19.6 To access & remove the Inspection panel.

1. Complete sections 19.1 - 19.5
2. Unscrew the 4 screws, then remove and place the screws and panel to one side carefully.
3. Any inspection or cleaning of debris necessary can now be carried out.
4. Replace in reverse order, a flue flow test should be carried out at this stage. Refer to the relevant section of BS5440 Part 1 for this procedure.

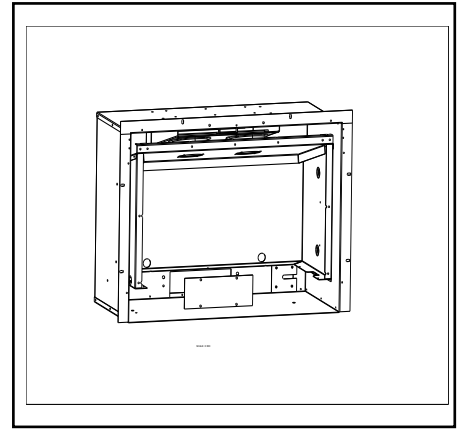

19.8 To remove the wall liners.

1. Complete section 19.1-19.6, The two side liners are resting in place, remove by easing them out holding the base of the liner.
2. There are finger holes in the inner convector box to allow easy access to gently push out the rear wall liner. These are marked by a notch in the metal work behind which the hole can be reached using your fingers.

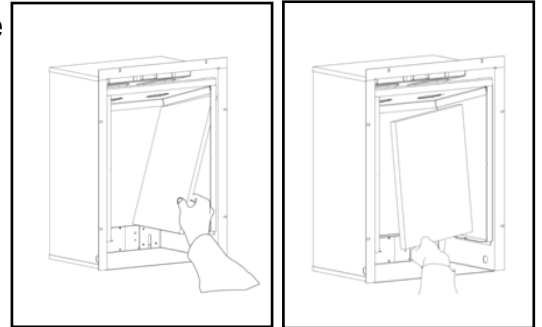

3. Gently guide the bottom of the liner wall out towards the inside of the convector box. Lift the liners clear of the convection box.
4. Replace in the reverse order.

19.9 To remove the Burner tubes (a) or Pilot unit (b).

19.9 (a) - Burner Tubes

1. Remove the burner assembly and top tray (Refer to sections 19.5 - 19.6).
2. Remove the LED glass panel & gasket carefully by unscrewing its two locating brackets.
3. Remove the inner tray tray by unscrewing the 3 screws
4. Access is now possible to to remove any of the 3 burners. Each burner is held in place with two screws, remove and carefully remove the burner gasket if necessary.
5. Refit in the reverse order, ensure when refitting the removed burner tube(s) that the gasket is replaced and the gap between each burner as shown of **40mm** is maintained.

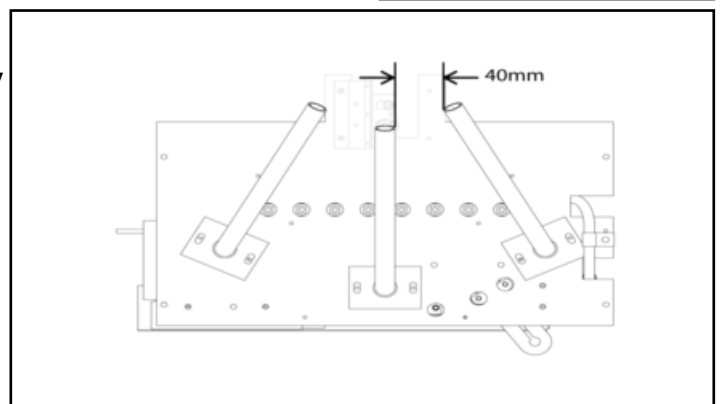
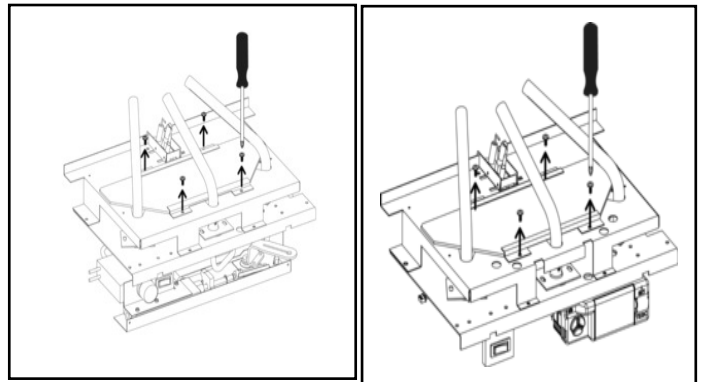

NOTE: Failure to maintain this gap could result in ignition issues.

19.9 (b) Pilot Unit

6. Carry out steps 19(a) 1 - 3.
7. Detach the pilot pipe from the pilot unit.

INSTALLER GUIDE

8. Detach the electrode lead from the underside of the electrode tab.

9. Detach the thermocouple by unscrewing the thermocouple nut at the gas valve.

10. Remove the two screws from the pilot bracket.

11. Remove the pilot bracket and pilot assembly.

12. Refit in the reverse order.

Note: The pilot unit is an atmosphere sensing device. It must be replaced as a whole assembly. Its individual components are not separately replaceable.

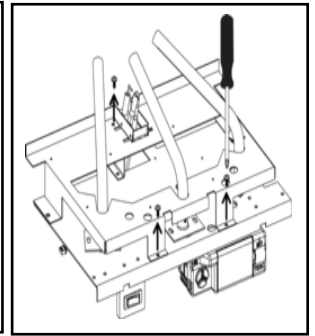
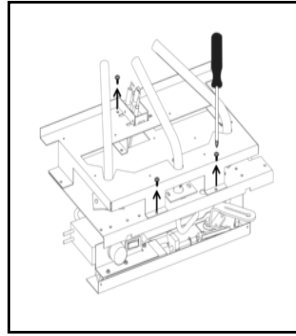

19.10 To remove the Teddington gas valve, LED On/Off Switch or ignition unit - FS only.

1. Remove the burner assembly (See section 19.1 - 19.6).

2. Turn the burner tray upside down, ensure that the work surface is suitably protected. This will avoid damage to the work surface and support the burner tubes.

3. Remove the thermocouple by unscrewing the thermocouple nut at the end of the valve.

4. The ignition spark generator has 3 wire connections the top single wire comes from the pilot and the bottom side by side wires comes from the valve switch. All 3 wires should be carefully pull out straightly and disconnected.

5. The On/Off switch has 2 wire connections both should be carefully pull out straightly and disconnected.

6. Detach the pilot/inlet & burner pipes from the gas valve.

7. Turn the burner assembly back over and unscrew the 4 screws holding the slider assembly onto the bottom tray. This will release the slider assy from the burner assy.

8. The valve is connected to the slider assembly by a screw in the connecting steel rod, remove this screw to disconnect from the slider arm.

9. Remove the two screws that retain the gas valve and top bracket from the base of the burner tray and lift the bracket and gas valve assembly clear.

10. Remove either the Gas Valve, Switch or Ignition unit as required.

11. Refit in the reverse order.

19.11 To remove the TESC gas valve, LED On/Off Switch or Manifold - RC only.

1. Remove the burner assembly (See section 19.1 - 19.6).

2. Turn the burner tray upside down, ensure that the work surface is suitably protected. This will avoid damage to the work surface and support the burner tubes.

3. Remove the thermocouple connections by carefully pulling out straightly and disconnecting the three wires at the rear of the gas valve.

4. Detach the pilot/inlet & burner pipes from the gas valve.

5. Unscrew the 2 screws holding the gas valve in place to release it.

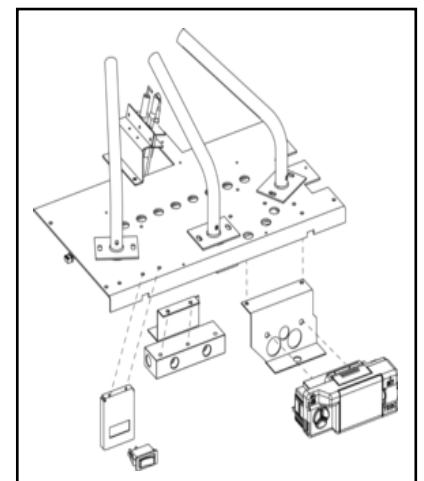
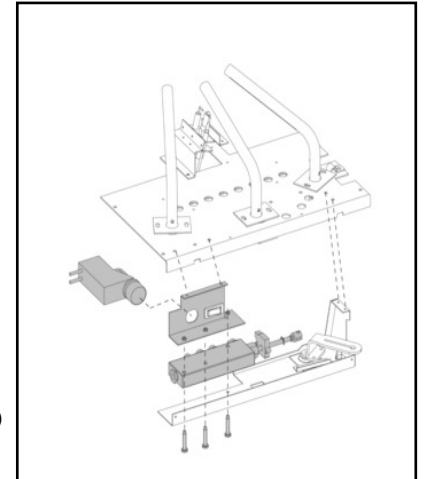

INSTALLER GUIDE

6. The Manifold is connected to the three injectors and to the gas valve loosen and remove these four nuts/pipe connections and two fixing screws to release.

7. The On/Off switch has two wire connections both should be carefully pulled out straightly and disconnected allowing the switch to be removed.

8. Remove either the Gas Valve, Switch or Manifold as required.

9. Refit in the reverse order.

19.12 To remove the burner injector(s).

1. Follow the steps in 19.10 (1 - 9) for FS and steps 19.11 (1 - 7) for RC.

2. Loosen and remove the three nuts onto the injectors along with their pipes.

3. Loosen and unscrew the injector (s) from the inner tray.

4. Refit in the reverse order.

19.13 To remove the LED strip or LED controller PCB.

1. Remove the burner assembly and top tray (Refer to sections 19.5 - 19.6).

2. Turn the burner tray upside down, ensure that the work surface is suitably protected. This will avoid damage to the work surface and support the burner tubes.

3. Disconnect the two receptacles onto the switch tabs by carefully pulling them off straight.

4. Unscrew the four screws as illustrated, then remove and place the screws and LED panel to one side carefully. This gives access to the LED strip held in place by two cable ties, which will require cutting open to replace the strip.

5. If it is the LED controller PCB that access is required to then unscrew the two remaining screws in the LED panel assembly to gain access. The PCB is loaded on four PCB mounting clips by squeezing them at the point they will release the PCB.

6. Refit in the reverse order along with fitting tight two new cable ties if changing the LED strip.

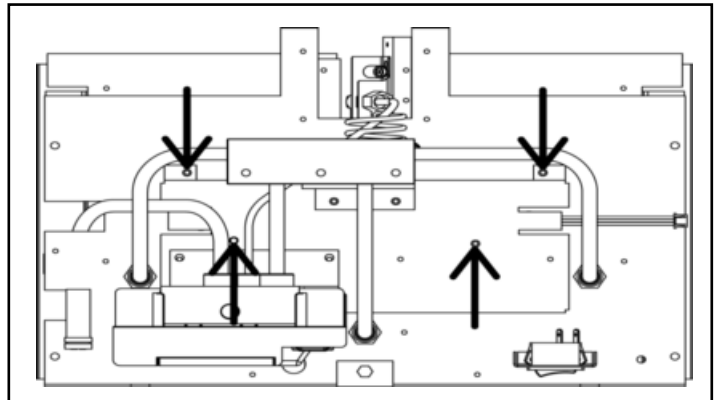

OWNER GUIDE

FOR WARRANTY, SERVICE AND BENCHMARK
INFORMATION SEE PAGES 55 TO 59

<u>Section</u>	<u>Page</u>
SAFETY (GAS & ELECTRICAL)	42 - 43
Appliance Minimum Clearances	43
GAS & ELECTRIC CONSUMPTION	44
OPERATING YOUR FIRE	44 - 52
The Oxysafe flame sensing and flue blockage safety system.	44
1. Operating the fire with SLIDER control (FS) model.	44 - 45
1a - Lighting the fire.	44
1b - Adjusting the flame height.	45
1c - To turn off using slider handle.	45
2. Operating the fire MANUALLY with Gas VALVE - (RS) model.	45 - 52
2a - Lighting the fire & operation of Gas Valve (without the use of handset)	45
2b - To turn on the fire manually	46
2c - To turn off manually the gas valve and fire	46
3. Operating the fire with REMOTE HANDSET - (RS) model.	46
3a - Lighting the fire & operation (using Remote handset)	46
3b - Operating instructions	47
3c - Setting the Time	47
3d - Setting the Display for "12" or "24" hour display	47
3e - Setting the Day of the week	48
3f - Setting the Hour	48
3g - Setting the temperature display to Celsius or Fahrenheit	49
3h - 24 hour Day Timer/Thermostat mode and snooze mode	49
3i - Setting "Snooze mode" in Manual operation	49
3j - Setting "Snooze mode" in Thermostatic mode	49 - 50
3k - Setting the "24 hour Day Timer/Thermostat" mode	50 - 51
3l - Paging feature built into remote handset to find its location	51
3m - Advanced setting menu	51

<u>Section</u>	<u>Page</u>
4. LED fuel effect operation.	52
CLEANING YOUR FIRE	52 - 53
Metal and painted parts.	52
Removing and cleaning the window assembly.	52
Cleaning anti-reflective “ Clear Vision ” coated glass	53
Ceramic fuel effect log pieces and convector box compartment walls.	53
Burner.	53
MAINTENANCE	54
Battery replacement.	54
Error codes (RC models only)	54
Spark ignition generator (FS models only)	54
Gas valve and Remote handset (RC models only)	54
Regular maintenance.	54
Replacement parts.	54
WARRANTY, SERVICE AND BENCHMARK	55 - 59
BENCHMARK COMMISSIONING CHECKLIST	57
BENCHMARK SERVICE RECORD	58
SERIAL NUMBER LABEL	59

This gas fire is designed to meet the most stringent quality, performance and safety requirements to provide you with many years’ trouble-free service.

This guide aims to improve your understanding and appreciation of your gas fire by providing simple and informative instructions to ensure that you benefit from the excellent performance and features it has to offer.

IF YOU SMELL GAS

- **DON'T SMOKE.**
- **EXTINGUISH ALL NAKED FLAMES.**
- **DON'T TURN ELECTRICAL SWITCHES ON OR OFF.**
- **TURN OFF THE GAS SUPPLY AT THE METER OR TANK AS APPROPRIATE.**
- **OPEN DOORS AND WINDOWS TO GET RID OF THE GAS.**
- **IMMEDIATELY CALL THE GAS EMERGENCY SERVICE FROM A NEIGHBOURS PHONE - GAS EMERGENCY CONTACT NUMBERS ARE;**
 - **England, Wales and Scotland** **0800 111 999**
 - **Northern Ireland** **0800 002 001**
 - **Republic of Ireland** **1850 20 50 50**

Do have the gas stove installed by a competent person i.e. Gas Safe Registered Installer (UK) or a Registered Gas Installer (Outside of UK). In the United Kingdom, installation must be in accordance with the latest edition of the Gas Safety (installation & use) Regulations. In the Republic of Ireland, installation must be in accordance with all national and local regulations in force.

Do have the chimney swept prior to installation if it was previously used for solid fuel.

Do have the gas stove installed in accordance with the installation instructions. On no account must the stove stand on carpets or other combustible materials. The stove must stand on a non-combustible hearth surface. The hearth material must be at least 12mm (1/2") thick and should protrude at least 150mm (6") in front of the stove body.

Do provide the minimum clearances shown and stated on page 43.

Do always use a fireguard complying with BS 8423 for the protection of young children, the elderly, the infirm or pet animals. The cast iron top, front, rear and sides of this stove are considered to be working surfaces and so will become very hot when in use. Always take care when using this appliance.

Do wait three minutes before attempting to relight if the gas stove is switched off or the flames are extinguished for any reason (Your gas stove is fitted with a safety device that will automatically shut off the gas supply to the gas stove, if for any reason, the flame goes out. If this operates then wait at least ten minutes before operating the stove).

Do get advice about the suitability of any wall covering near your gas stove. Soft wall coverings (e.g. embossed vinyl, etc.) which have a raised pattern are easily affected by heat. They may, therefore, scorch or become discoloured when close to a heating appliance. Please bear this in mind whenever you are considering redecorating.

Do not use this stove with the door open or with the glass panel damaged or removed. The door should always be secured shut (See "Cleaning your appliance"). If the window is damaged or will not close securely the stove must be turned off and not used until the window is changed or corrected by a competent service engineer.

OWNER GUIDE

Do not hang clothing, towels or any other fabrics over the gas stove.

Do not put more loose ceramic logs on the gas stove than the number given in the guide supplied with the ceramic fuel effect. This may have been attached to or placed inside this guide. Never use any ceramic coals other than those authorised for this gas stove. Incorrect combustion and subsequent health hazard could result.

Do not put paper or other materials into your gas stove.

Do not use the gas stove with damaged ceramics.

Do not place any combustible material (rugs, carpet, plastic tiles, etc.) on the hearth.

Do not attempt to clean or service the gas stove until it has been switched off and allowed to cool completely.

Do not leave the stove on if the house is left unoccupied for a long period. We recommend that the stove is turned fully off.

ELECTRICAL SAFETY

- Before switching on, please read the operating instructions fully.

NOTE: This appliance is **ONLY** to be used with the power supply unit provided. Only plug this appliance into a supply that corresponds to that displayed on the power supply unit. The appliance must only be supplied at extra low voltage corresponding to the markings on the appliance.

- Unplugging, in the event of a fault unplug the device. It is also recommended to unplug the device when not required for long periods.

- Damage, if the transformer or its lead is damaged it must be replaced by the manufacturer or service agent or a similarly qualified person in order to avoid a hazard.

Appliance Clearance Minimum Dimensions;

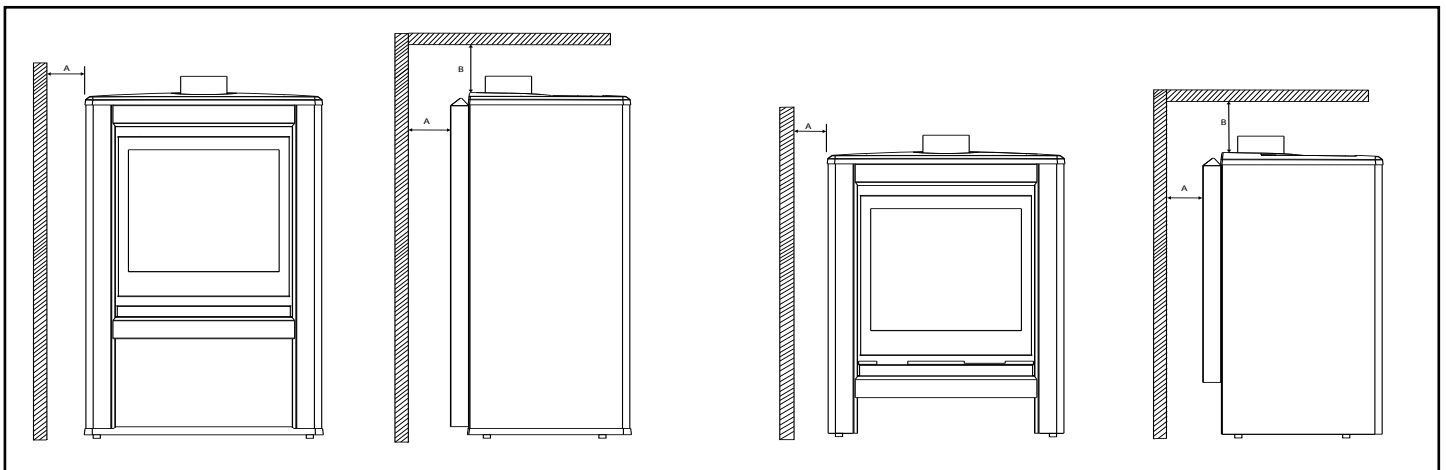

Clearance Dimensions	L & M	L & M
	A (Sides)	B (Shelf)
Minimum to Combustible Material	100 mm	-
Minimum to Combustible Shelf	-	300 mm
Minimum to Non-Combustible Material	50 mm	-
Minimum to Non-Combustible Shelf	-	100 mm

OWNER GUIDE

GAS & ELECTRIC CONSUMPTION

Natural Gas - Inspire Stove M or L fitted with 401FS engine

Maximum	(HIGH)	NG input of	5.3 kw (Gross)
Medium	(MED)	NG input of	2.0 kw (Gross)
Minimum/ignition	(LOW)	NG input of	1.6 kw (Gross)

Natural Gas - Inspire Stove M or L fitted with 401RC engine

Maximum	(HIGH)	NG input of	5.3 kw (Gross)
Minimum/ignition	(LOW)	NG input of	2.5 kw (Gross)

LED circuit	Max operating power of	1.2W
-------------	------------------------	------

OPERATING YOUR FIRE

PLEASE NOTE

When operating your fire for the first time, some vapours may be given off which may cause a slight odour and could possibly set off any smoke alarms in the immediate vicinity. These vapours are quite normal with new appliances. They are totally harmless and will disappear after a few hours use.

The Oxysafe flame sensing and flue blockage safety system.

For your safety, this appliance is fitted with a flue blockage safety device which will shut down the appliance in the event of abnormal flue conditions.

This device is NOT a substitute for an independently mounted Carbon Monoxide detector.

The device will also automatically shut off the gas supply to the fire if the pilot flame goes out due to lack of oxygen or for any other reason.

If this device starts to repeatedly shut off the gas, get expert advice.

This device incorporates a probe which senses that the heat from the pilot flame is correct. If this probe is cool, the device will prevent any gas flow unless the control knob is held in at the ignition position.

If, for any reason, the flames go out when the fire is hot or if the fire is turned off when hot, always ***wait at least three minutes before attempting to relight.***

Operations of the fire.

Fireslide (401FS model)

1a - Lighting the gas fire. Push the slider handle to the LEFT as far as possible till the ignition position is reached, several sparks will occur between the electrode and pilot tip. Hold in this position till the pilot flame has heated the thermocouple sufficiently to hold. **Approx. 5 - 15 seconds.**

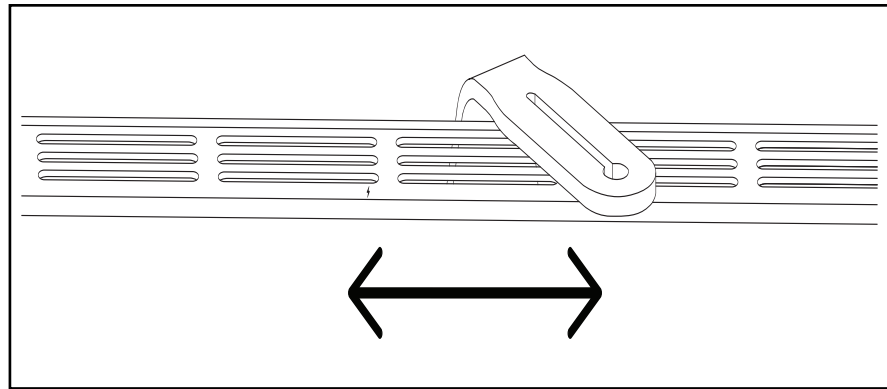

1b - Fireslide - adjusting flame height.

When the burner is operating step the slider handle to the RHS, increments will be felt as the slider moves giving you the following outputs;

Position 1 - After ignition Center burner is on LOW

Position 2 - Moving slider handle one increment to RHS, Center burner is on HIGH.

Position 3 - Moving slider handle one more increment to the RHS, both Outer burners on HIGH ignite (along with the Center burner remaining on HIGH)

Position 4 - Moving the slider as far as possible to the RHS is OFF

Note: *There is no pilot only setting on the Slider (FS) model.*

1c - Fireslide - turning OFF.

To turn the fire OFF push the slider as far as possible to the RHS.

2. Gas valve control (401RC model)

2a - Lighting the gas fire & operation The gas valve control is situated on your fire. The drawing below shows the main features of the control.

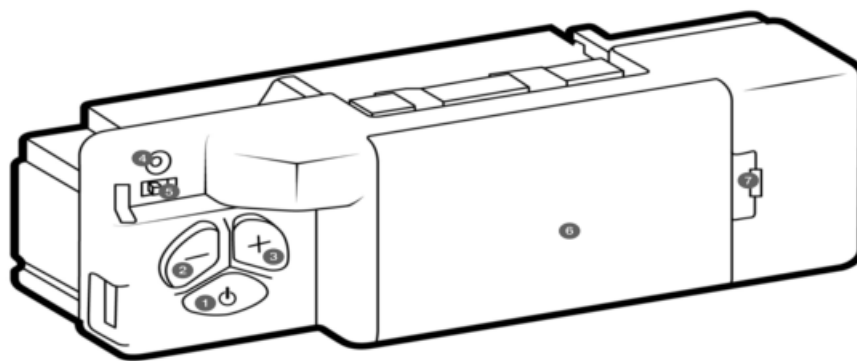

- | | |
|-------------------|---|
| ① Power button | ⑤ Power isolator switch (sliding) |
| ② Decrease flame | ⑥ Battery compartment cover |
| ③ Increase flame | ⑦ Battery compartment cover opening lever |
| ④ Indicator light | |

OWNER GUIDE

The control required 3 AA size alkaline batteries to be inserted under the battery compartment cover. The orientation of these is shown moulded into the battery compartment and as shown below.

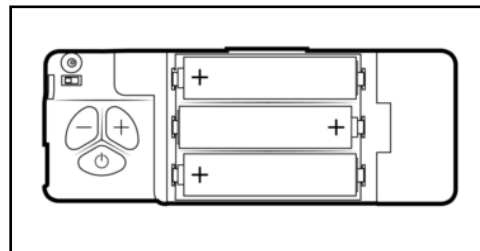

After fitting the batteries and replacing the cover the fire can now operate.

Slide the valve control On/Off switch to the right to the On position (I symbol).

2b - To start the fire manually (without the use of the Remote control handset), press the power button and hold for 1 second then release. The burner will within around 1 to 10 seconds, adjust to the maximum power setting. The power of the burner can be adjusted up and down by pressing the – and + buttons.

2c - To turn off the fire, press the power button again and the burner will stop.

3. Remote handset (401RC model)

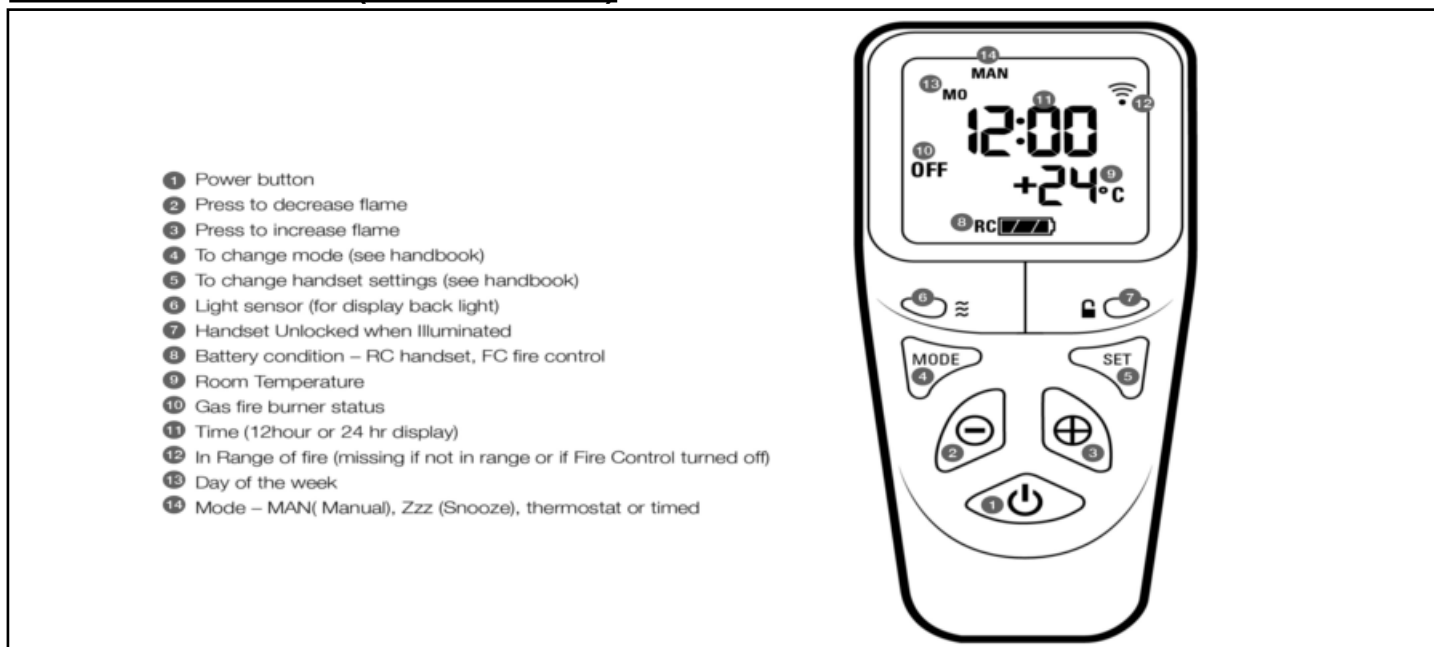

3a - Lighting the gas fire & operation

NOTE: Ensure the power isolator switch on the front corner of Fire Control is in the on position.

To activate the handset - Grasp around the handset to unlock its functions. The green unlock light will illuminate to show when the handset is unlocked and ready to accept commands. (N.B. Keep a grip of handset to keep it unlocked, to continue to operate the command buttons.)

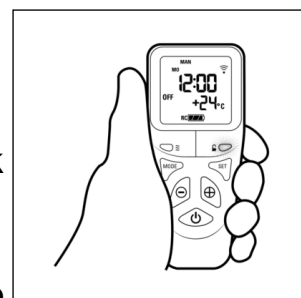

Power button – To turn on the fire, with one hand grasp around the rear of both sides of the button area control. The green unlock light will illuminate. Keep the handset held to keep the control unlocked, to enable operation of the buttons. Then with the other hand touch and hold a finger on the power button for about 3 seconds. (A short beep and a flash of the unlock light will happen upon touching.) When the word “pilot”

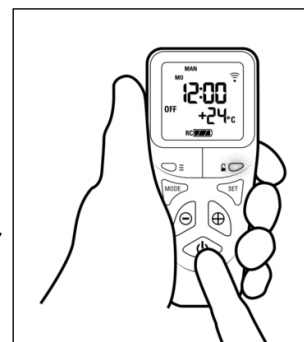

OWNER GUIDE

appears at the bottom left hand corner of the display, immediately release the power button. (A second flash of the unlock light and a longer beep will also sound at the time to release the power button). The Fire should be lit within a few seconds.

N.B.

If power button is held for more than a few seconds after second flash/beep/word pilot appears, the command is ignored for safety reasons.

Similarly, if it is released too soon before the word pilot appears, the command is also ignored.

The control has been designed to ensure that only intended ignition of the fire occurs. To stop – with handset held to unlock it, press then release power button.

3b - Operating instructions

Upon successful insertion of the batteries into the Handset the display will be as shown. The handset will be supplied paired to the fire and all that is required is to set the time of day and select if a 24h hour clock or 12 hours clock display is required and if temperature display is on Celsius or Fahrenheit.

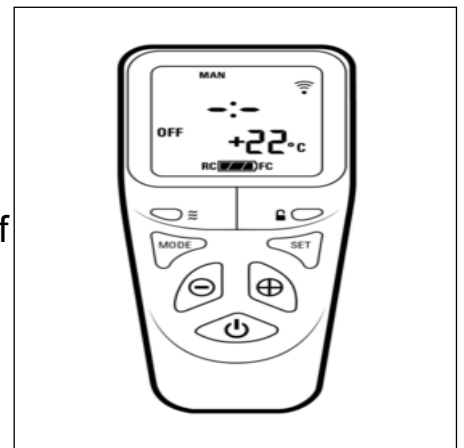

3c - Setting the time

Holding the handset as described previously to unlock the keypad, press and hold "SET" for a few seconds and the display will be as shown

3d - Setting the display for 12 or 24-Hour display

As always when pressing the remote-control buttons keep the control held to keep the green light on and therefore handset safety feature, unlocked.

The H indicates that it is time to set the timer to either 24-hour display or 12 Hour (AM or PM) display.

Press the + or – button on the handset to toggle between the two settings. When you are ready to confirm the setting you want press the "SET" button to progress to setting the day of the week.



3e - Setting the day of the week

Press and release the + and – buttons until the correct day of the week is shown on the display.

(Mo = Monday, Tu= Tuesday, We=Wednesday, Th=Thursday, Fr=Friday, Sa=Saturday and Su=Sunday).

Press “SET” to accept the day of the week and to progress to setting the Hour of the day.

Note: Whilst doing this setup pressing “SET” advances to the next display and pressing “MODE” will return you to the previous display setting.

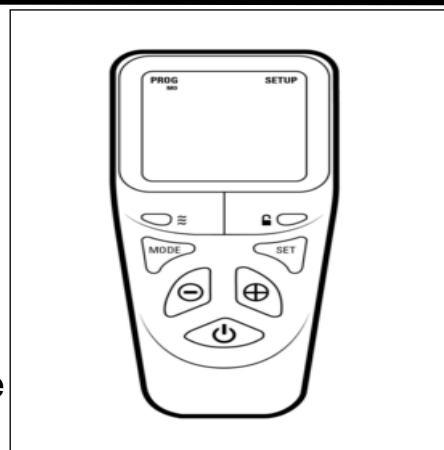

3f - Setting the Hour

Press and release the + or – button to change the hour to the correct hour and press set to store and to move to setting the minute.

Repeat this for setting the minutes.

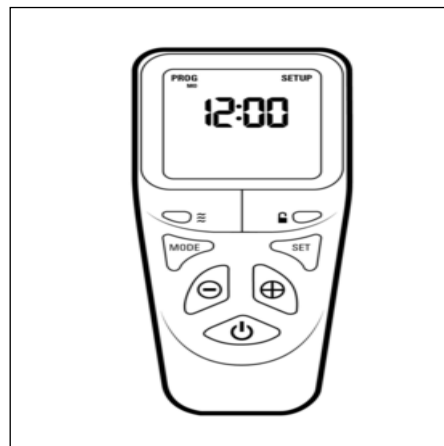

3g - Setting the temperature display to Celsius or Fahrenheit.

Press and release the + or - button to toggle between C and F. When the display shows the desired symbol, press and release the “SET” button to store.



As the important settings above have now been done. Press and hold (not releasing straight away) the “SET” button for a few seconds and this will exit the setup menu. (alternatively, you can press and release the set button several more times until the time of day is displayed on the handset.

The control is now ready for use with the gas valve control.

Note: the legend at the bottom shows the battery condition of both the batteries in the hand set and in the fire control alternately.

RC = Remote Control handset and FC = Fire control.

The control is designed to get the most out of the batteries but when eventually the display shows they are spent (when the battery legend is an empty area, we recommend you change the batteries in the handset before they are flat, to avoid having to reprogram the time of day in again.

N.B. Pairing is not lost, even if the batteries are removed or flat. The pairing is not lost when the batteries are flat but replacing them quickly before they have gone flat will avoid having to set the time of day, day of the week etc again)

3h - 24-hours Day Timer/Thermostat mode and snooze mode.

Snooze mode can be selected to work with in conjunction with either manual or thermostatic modes.

You can switch between modes at any time with the handset unlocked by pressing and releasing mode button to toggle between modes.

Note: If at any time the power button is pressed during operation, this will stop the fire and exit any automatic mode and return the handset to manual (**MAN**) operation mode.

3i - Setting “snooze mode” in manual operation

Snooze mode is a time period you can set which will turn off the fire after a certain time period has elapsed.

The snooze time period can be set before or during manual operation of the fire. Hold the handset to unlock as described previously and press the mode button as many times as necessary until the word **MAN** and the **Zzz** symbols are flashing at the top of the display. Press and release the set button and this will put the control into Manual snooze mode.

The default time period for the snooze time period is 1:00 hour. Pressing the set button again will show you the snooze time period remaining. This can be adjusted by pressing the “+” or “-” buttons. The timer period that can be set is from 1 minute to 4:00 hours.

After adjusting the time, press set again to enter the time setting required (or if left for a few seconds this time is now stored and used).

Once this countdown timer has reached zero the fire will turn off (as if you had pressed off manually, it does not recycle).

3j - Setting “snooze mode” in Thermostatic mode

The same thing as above can be done before or during a thermostatic mode operation.

The handset has within it a thermostat sensor and this can be set so the fire will heat the room to match the temperature set in the handset.

There are 3 temperature types that can be set: -

-Day mode temperature that has a sun symbol on the display – the default temperature is 24 C

- Night temperature that has a half moon symbol on the display- the default temperature setting is 18 C

-frost protection that has a snowflake symbol on the display – the default temperature setting is 5 C

Hold handset and press and release the mode button several times as necessary until the display has a thermometer symbol flashing at the top of the display. Press the set button to enter this mode.

Press the set button again to see the temperature setting that is set and the mode (the default is 24 C) and on the left of the display is a sun symbol showing it's the day temperature.

OWNER GUIDE

If a different set temperature is required, while the display is showing this set temperature, press the + and – buttons to alter the setting. When finished either press set or leave and after a few seconds the new setting will be accepted and the display will return to the time of day screen.

On the anniversary of the net minute of the clock, the set temperature will be compared to the actual temperature displayed on the handset (i.e. the room ambient temperature around the handset). If the room temperature is higher than the set temperature the fire will not light until the room has cooled to below the set temperature. The fire would then automatically turn itself on when the room is cooler than the set temperature and down and off if necessary when it is hotter than the set temperature.

Note- when the set temperature is reached while the fire is in operation, the fire reduces the burner power level each minute until the burner is off.

The pilot (if fitted) will remain on for a further 30 minutes and if the set temperature is still too high; the pilot will then also extinguish. When the set temperature is higher than the actual temperature, the fire will automatically light and go to the full burner rate to reheat the room back to the set temperature.

Note: If at any time the power button is operated during Thermostat mode, the control will cancel any thermostat operation and return the control to manual mode.

For ease of setting there are two other modes that can be selected as stated above. Night mode (moon symbol) and frost protection setting (a snow flake). These can be selected (and adjusted if necessary) by pressing set then mode while in thermostat mode. Pressing mode button toggles through from day to frost modes. The purpose of these settings is to help your fire to automatically protect you home against becoming too cold if there is a sudden change in the weather. The control must be left in the appropriate mode for this to function.

Note: As stated in an earlier section, snooze function can also be operated in conjunction with thermostat mode. The thermostat symbol and the **Zzz** symbol will be on together when in this mode.

3k - Setting the “24-hours Day Timer/Thermostat” mode

This mode enables the various day, night and frost thermostat modes to be set on a program timer. The control will work as a thermostat switching between the day, night and frost temperature settings in line with the program set. The setup of the timer will be shown by a demonstration.

To set up the timed thermostat to be at 24 C from 06:00 to 09:00 then drop to 18 C from 09:00 to 15:30 and then 24 C again from 15:30 until 23:30 and then to protect from frost a 5 C setting between 23:30 to 06:30 the next day from Monday to Friday this is what you would do: -

Hold handset to unlock – press set and hold until a beep and release. Press **MODE** button until the timer symbol is flashing on the top of the display – press **SET** to enter the time mode – Mo is flashing so it is already set for Monday- press **SET** and release now press the + and – buttons to make the time of day read 06:00 (note the steps are in 15 minutes steps) – press **SET** and release- press + and – to make the

next symbol show a flashing sun symbol- press and release **SET**- as Mo is flashing press and release **SET** again, enter the next time of 09:00- press and release **SET**- change the flashing sun symbol to a flashing moon symbol by pressing and releasing the + and – buttons then press and release **SET** again to store the moon setting continue this until you have entered each time and temperature change required for each day.

To put the fire into thermostat timer mode press and release the **MODE** button until the thermostat and timer symbols are displayed on the display at the top. Press and release the **SET** button and the control will now run the timed program set up in the memory. To adjust any time setting in the memory re-enter the timer program setup mode (by pressing **SET** and then **MODE** as described above). Then press set to make the time flash. Now holding the + button advances the display to the next setting and so on throughout the program. Amend the appropriate setting and when finished do a long press of the **SET** button to exit the program mode.

To rest the whole timer program in the memory: - Hold handset- press set- press mode until **SETUP** is flashing- press **SET** to enter SETUP- press **SET** about 8 times until **CP0** is flashing on the display use the + and – buttons to change the display to **CP1** – press SET – press **SET** again and the display will return to standby Manual mode and the timer setting have been completely removed for the timer memory.

3l - Paging feature built into remote handset to find its location

If you have misplaced the handset (and it is in range of the fire), you can page it by pressing the + button only on the fire control for around 5 seconds. The handset will flash and make a noise to help you to locate it. Once you pick up the TESC it knows you hold it and so the sound stops. The flashing and sound will last for 60 seconds each time the handset is paged as described. If not found in 60 seconds, page again and so on.

NOTE: PRESS “+” Button ONLY, NOT “+” and “-” Together as you will accidentally break the handset pairing and have to reset handset to factory state and pair again (see other Page 25 of the booklet if this happens).

3m - Advanced settings Menu

In the event that you may wish to change the other pre-set settings of the control features.

Do not do a long press and hold above but a normal short press and release will take you into the advanced settings area.

Advanced settings options are: -

Back light –

A = Automatic (default setting). The back light comes on in the dark but not in the light.

0 = Light never comes on.

1 = Light comes on whenever handset is unlocked.

Display contrast – 8 levels from 0 to 7 (default level 4).

OWNER GUIDE

4. LED fuel effect operation.

Ensure the transformer is plugged into a suitable mains supply and the wall socket is switched ON.

Switch ON the LED fuel effect simply by flicking the rocker switch as shown resulting in the red marking showing. The 8 LEDs will come ON and begin gently pulsing.

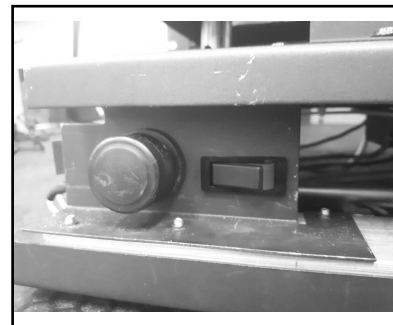

NOTE: If no LEDS function check the Transformer wall socket switch is in the On position and the On/Off switch on the appliance is in the correct position.

NOTE: The LED circuit is separate to that of the gas and its ignition circuit, so they can both be operated separately or together to give the desired effect.

CLEANING YOUR APPLIANCE

To maintain the high performance and quality finish of your fire please follow these guidelines:

– Before attempting to clean the appliance, please remember to turn off the appliance and wait for the appliance to cool completely. The fire will retain heat for some time before cleaning can begin.

Metal and painted parts.

- Clean the metal and painted parts with a slightly damp, lint free non-abrasive cloth and then dry.
- Do **not** use abrasive cleaners, as these will scratch the appliances surface.

Removing and cleaning the window assembly.

Removal of the window assembly is only necessary if you wish to clean the rear of the window or access the ceramic components. The window assembly can be cleaned with a mild detergent and water. Glass cleaner can also be used. Any stains on the glass can be removed with a non-abrasive cleaner such as a ceramic hob cleaner. Never use abrasive cleaners. Clean the window carefully in accordance with the instructions supplied with the cleaner.

- 1.** The window door panel is secured at the bottom with one hand tightened M5 knurled screw.
- 2.** With this knurled screw removed, gently pull the base of the window panel forward.

Hold the window panel base and lift upward until clear.

3. To remove the window door panel easier remove the visual baffle first.

Cleaning anti-reflective “Clear Vision” coated glass

Fingerprints are more visible on anti-reflective coated glass: it is advised to wear (rubber) gloves when handling the panel. Coated “Clear Vision” glass panels can be cleaned by using a non-abrasive glass cleaner and a soft cloth. Cleaner and cloth used must not be scraping or abrasive. Use the cleaning products according to instruction of use and only on cold surfaces. Particularly successful is a mixture of distilled water and white spirits (at the ratio of 1:1). Abrasive cleaners (like glass ceramic cleaners) or sharp-edged objects **MUST NOT** be used.

Clean the inside and the outside of the glass regularly. Ensure the glass is fully dried before turning back on your gas fire.

NOTE: Regular cleaning of the glass is necessary to ensure the panel does not become dull and difficult to clean.

Ceramic fuel effect log pieces and convector box compartment walls.

To gain access to the ceramic components the window door assembly must be removed as in the previous Section 9 (1&2).

This product uses fuel effect pieces, burner compartment walls and ceramic pebbles containing Refractory Ceramic Fibres (RCF), which are man-made vitreous silicate fibres. Excessive exposure to this material may cause irritation to eyes, skin and respiratory tract. Consequently, it is important to take care when handling these articles to ensure that the release of dust is kept to a minimum.

– Light coatings of soot will usually be burnt off during the normal operation of the fire. Should any soot accumulation become excessive, the effected overlay log or ceramic fuel effect base should be removed from the fire for cleaning.

– Cleaning should be carried out in a well ventilated area or in the open air by gently brushing with the pieces held away from your face so that you avoid inhaling the dust.

– We do not recommend the use of a normal domestic vacuum cleaner which may blow dust back into the air.

– We suggest that you remove the ceramic fuel effect kit pieces in the reverse order to that shown in Section 15.

– Once cleaned replace the log fuel effect kit as in Section 15.

Burner.

To gain access to the burners the window assembly and the 3 large log ceramic components must be removed as in the previous sections.

Remove any deposits of soot or other foreign matter from the surface of the burner with a dry soft brush. Be careful not to brush any particles into the open slots.

Remove any particles from the slots with a vacuum cleaner fitted with a soft brush attachment. Before using a vacuum cleaner remove all Pebbles/Chips and flakes.

Do not poke wire, etc. into the slots in the burner.

Battery replacement.

Note: *In order to ensure maximum battery life and optimal performance, we recommend that only 'Long Life' alkaline type replacement batteries are used - Low powered batteries in the valve or handset can generate false Error codes.*

Error codes (RC models) these could be generated on the handset (i.e. E00). These can be reset / cleared by; Activate the handset, then press and hold 'ON' power button continuously for 3 - 5 seconds. They can also be reset / cleared by pressing 'ON' power button on the valve for same time period. If the error codes repeat please contact our customer service team for further assistance.

Spark ignition generator (FS models)

The spark ignition generator are battery powered. To replace the single 'AA' battery required it is not necessary to remove the visual baffle but you may do so if easier access required. At the front of the electronic spark generator there is a removable circular battery cover. Unscrew the cover in an anticlockwise direction.

Remove any protective film from the new battery if applicable and place into the generator. The negative (-) terminal should go in first. The battery is marked with (+). Screw back on the cap.

Gas valve and Remote handset (RC models)

The gas valve and remote handset are both battery powered. To replace the gas valve please use three 'AA' batteries and the remote handset requires two 'AA' batteries. Note: It is necessary to remove the visual baffle to gain access to change the gas valve. Remove any protective film from the new batteries if applicable and place into the devices. Please follow the instructions as to the correct orientation of the batteries.

Regular maintenance.

In order to achieve and maintain high levels of personal safety and performance efficiency, In the United Kingdom it is the law that a landlord must have any gas appliance, flue and pipework which is situated in a tenant's premises checked for safety at least every twelve months by a competent person (GAS SAFE REGISTER operative).

We recommend that all gas appliances and their flues, wherever situated, are checked annually.

The service engineer must complete the relevant Service Record on **Page 58** after each service.

Replacement parts

If you wish to replace the ceramic log fuel kit / liners / remote handset / transformer, etc spare parts are available from our customer service team call the UK Helpline on **0844 879 35 88** or from the Republic of Ireland on **01 842 8222**.

Standard Warranty Terms & Conditions

The warranty is for 12 months subject to contract.

In the United Kingdom servicing can be carried out either by a **GDC** service operative or a **GAS SAFE REGISTER** operative. You must register your fire by calling our telephone registration line on **08444 810 214**.

This product should be serviced annually to optimise its safety, efficiency and performance. The GAS SAFE REGISTER service engineer must complete the relevant Service Record on the Benchmark Checklist after each service.

It is also a requirement of the warranty that the fire has an annual service (every 12 months) in accordance with the installation and servicing instructions.



Benchmark Checklist/Service Record

Please ensure that the installer has fully completed the Benchmark Checklist on the inside back pages of the installation instructions supplied with the product and that you have signed it to say that you have received a full and clear explanation of its operation. The installer is legally required to complete a commissioning checklist as a means of complying with the appropriate Building Regulations (England and Wales).

Installations carried out in England and Wales must be notified to Local Area Building Control either directly or through a Competent Persons Scheme. A Building Regulations Compliance Certificate will then be issued to the customer who should, on receipt, write the Notification Number on the Benchmark Checklist.

The filled in Benchmark Checklist/Service Record by the installer will be required in the event of any warranty (UK and Ireland installation).

After servicing, complete the relevant "Service Interval Record" section of the Benchmark Checklist located on the inside back pages of this document.

Our promise to you

If you experience a fault with your new gas stove, we aim to provide a safe and high quality repair service supported by our dedicated national network of highly skilled operatives.

If your installer can't resolve the problem for you, we will do everything we can to get an operative out to you as quickly as possible. Nothing in this warranty will affect your statutory rights.

-What you need to do if you experience a problem with the operation of the fire:

– You should always contact your installer first, because the cause of the fault may not be related to the fire.

– If your installer confirms that the fault is with the fire and they can't repair it, our friendly customer service team is on hand to help.

– Simply call our UK Helpline on **0844 879 35 88** or from the Republic of Ireland on **01 842 8222** for any general advice that you may need.

When calling the **Helpline**, it would be helpful if you could have the following information to hand:-

1. Stove serial number/barcode*
(Located on the appliance data label, also on this manual).
2. Date of installation*
3. Your installer name and address details*
4. Stove make and model number*
5. Annual Service record details*
6. Proof of purchase (if you do not have the appliance serial number)

***Note: details 1 – 5 should be recorded as part of the Benchmark Checklist / Service record at the end of this guide.**

What this warranty covers

Free of charge repair or replacement of components found to be of faulty manufacture.

Free of charge replacement of the complete unit providing the failure is related to a manufacturing fault that cannot be repaired or is uneconomic to repair.

What this warranty does not cover

Repairs to fires which haven't been installed and commissioned properly and as set out in the installation instructions.

Faults caused by inadequate supply of gas or electricity (where applicable).

Reimbursement of any third party repair or replacement costs that we haven't been told about or agreed with you in advance.

Compensation or consequential losses (e.g. loss of earnings, business losses, stress and inconvenience) arising from a production breakdown, including repair delays caused by factors outside our reasonable control.

OWNER GUIDE

GAS FIRE COMMISSIONING CHECKLIST

This Commissioning Checklist is to be completed in full by the competent person who commissioned the gas fire as a means of demonstrating compliance with the appropriate Building Regulations and then handed to the customer to keep for future reference.

Failure to install and commission according to the manufacturer's instructions and complete this Benchmark Commissioning Checklist will invalidate the warranty. This does not affect the customer's statutory rights.

Customer name:	Telephone number:
Address:	
Gas Fire make and model:	
Gas Fire serial number: <input type="text"/>	
Commissioned by (PRINT NAME):	Gas Safe register number:
Company name:	Telephone number:
Company address:	
Commissioning date:	
Building Regulations Notification Number (if applicable):	

Site Requirements	Yes	N/A
Was the chimney checked to ensure it only serves one flue/fire, has no obstructions and is continuous?		
Has any debris at the base of the chimney been removed?		
For brick chimney installations is there enough depth for 12 litres of debris, or precast flues 2 litres of debris? (see instructions for debris gap details)		
Have damper and register plates been removed or locked in the fully open position ensuring correct size of flue is maintained?		
If previously used for solid fuel has the chimney been thoroughly swept?		
If the chimney is pre-cast has the inside of the flue been checked for extruded cement / sealant which must be removed?		
Has the fire place been checked for under-floor air supply which must be sealed off?		
Has the chimney been inspected prior to fitting the gas fire to ensure that it is in good condition?		
Has the structure of the chimney been checked for leakage using a smoke pellet test? (See BS5440-1 for details).		
Ventilation		
Does the installation require any additional ventilation requirements as detailed in the manufacturer's instructions?		
Hearth Requirements- where fitted		
Is the hearth constructed from non-combustible material?		
Is the hearth a minimum of 12mm thick with a minimum floor to top surface of 50mm?(BS5871) or as per manufacturer's instructions?		
Is the hearth for open fronted fires a minimum of 760mm wide and has 300mm projecting from the fire opening (BS6871) or to manufacturer's instructions?		
Mounting height (where applicable) has the fire been installed to the correct mounting height- as per manufacturer's instructions?		
Firebox and Fuel Bed		
Has the fuel bed, coals, pebbles etc. been fitted to manufacturer's instructions?		
Gas Supply		
Has an isolation tap/restrictor inlet elbow been fitted for servicing?		
Has the gas supply been thoroughly purged prior to connection to remove any debris?		
Has a gas tightness test been completed prior to breaking into the gas supply and following completion of installation?(IGEM/UP/1B)		
Record burner gas pressure reading? If only the supply pressure is available a gas rate must be undertaken.(GSIUR REG26/9C)		
Record dynamic inlet gas pressure (working pressure) reading (all gas appliances running)		
Spillage test		
Installation passes smoke match test with any extractor fans turned on (see manufacturer's instructions)		
Installation		
Has the gas fire been installed and commissioned in accordance with manufacturer's instructions?		
Has the fire been installed with the correct clearance to combustible materials, as per manufacturer's instructions?		
The operation of the appliance and controls have been demonstrated to the customer including battery replacement where applicable?		
The manufacturer's literature, including Benchmark Checklist and Service record has been explained and left with the customer?		
Has the appliance been registered with the Local Authority as detailed on the Gas Safe web site and is a legal requirement and forms part of the warranty?		
Customer's Signature: (To confirm satisfactory demonstration and receipt of manufacturer's literature)	Commissioning Engineer's Signature:	

*All installations in England and Wales must be notified to be Local Authority Building Control (LABC) either directly or through a Persons Scheme. A Building Regulations Compliance Certificate will then be issued to the customer.



OWNER GUIDE

SERVICE RECORD

It is essential that your gas fire is serviced regularly and that the appropriate Service Interval Record is completed.

Service Provider

Before completing the appropriate Service Record below, please ensure you have carried out the service as described in the manufacturer's instructions. Always use the manufacturer's specified spare part when replacing controls.

SERVICE 01	Date:	SERVICE 02	Date:
Engineer name:		Engineer name:	
Company name:		Company name:	
Telephone No:		Telephone No:	
Gas safe register No:		Gas safe register No:	
Comments:		Comments:	
Signature		Signature	
SERVICE 03	Date:	SERVICE 04	Date:
Engineer name:		Engineer name:	
Company name:		Company name:	
Telephone No:		Telephone No:	
Gas safe register No:		Gas safe register No:	
Comments:		Comments:	
Signature		Signature	
SERVICE 05	Date:	SERVICE 06	Date:
Engineer name:		Engineer name:	
Company name:		Company name:	
Telephone No:		Telephone No:	
Gas safe register No:		Gas safe register No:	
Comments:		Comments:	
Signature		Signature	
SERVICE 07	Date:	SERVICE 08	Date:
Engineer name:		Engineer name:	
Company name:		Company name:	
Telephone No:		Telephone No:	
Gas safe register No:		Gas safe register No:	
Comments:		Comments:	
Signature		Signature	
SERVICE 09	Date:	SERVICE 10	Date:
Engineer name:		Engineer name:	
Company name:		Company name:	
Telephone No:		Telephone No:	
Gas safe register No:		Gas safe register No:	
Comments:		Comments:	
Signature		Signature	



OWNER GUIDE

A LABEL CONTAINING THE SERIAL NUMBER AND BARCODE MAY HAVE BEEN PLACED INSIDE THIS BOX.

SERIAL NUMBER LABEL
TO BE AFFIXED HERE

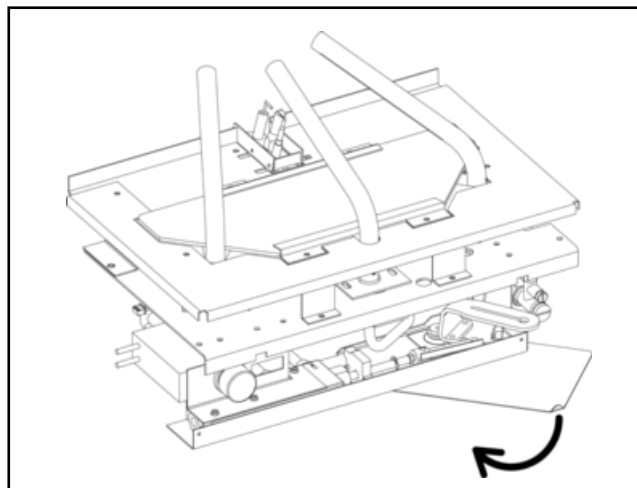

Pic shows FS data label
metal plate position.

Note: The Data label located on the burner assembly also contains this matching Serial number and Barcode information.

- FS models at the Inlet fitting there is a bent up metal tab, which when pulled forward rotates out a metal plate containing this information
- RC models this plate is chained to the engine pipework for access.



